



PRODUCT CATALOG

2016-17



LXT
LITHIUM-ION **BRUSHLESS**

BRUSHLESS
18V X2
36V

INNOVATIONS



STAR TECHNOLOGY

STAR
PROTECTION
COMPUTER CONTROLS™



PROTECTS BATTERY
AGAINST
**OVERLOAD
OVER-DISCHARGE
OVERHEAT**
WITH BATTERY
& TOOL

CORDLESS
Pgs. 10-34



BRUSHLESS 18v X2 TECHNOLOGY

NO LIMITS
POWER & SPEED TO
UNPLUG THE CORD



UNPLUG YOUR CORDED TOOLS
and pick up Makita's 18v X2 (36V)
Lithium-Ion line up. Get the freedom
you need to reach new heights with
unmatched power and run time -
you'll never look back.

CORDLESS
Pgs. 17-25



ADVANCED AVT® - ANTI VIBRATION TECHNOLOGY

**SIGNIFICANTLY
LESS VIBRATION**

**MECHANICAL / AIR ACTUATED
COUNTERBALANCE**
VIBRATION ABSORBING HOUSING
INTEGRATED DAMPER SPRING

CONCRETE
Pgs. 38-39



MM4® - MAKITA 4-STROKE ENGINE

LOWER EMISSIONS
LESS NOISE
REDUCED OPERATING COSTS



CONCRETE
Pg. 43

POWER
EQUIPMENT
Pgs. 88-89



SJS® II- SUPER JOINT SYSTEM TECHNOLOGY

VIBRATION REDUCTION
SJS™ II provides a leaf spring
and cam gear drive mechanism
engineered to reduce vibration
for increased operator comfort
during extended use.

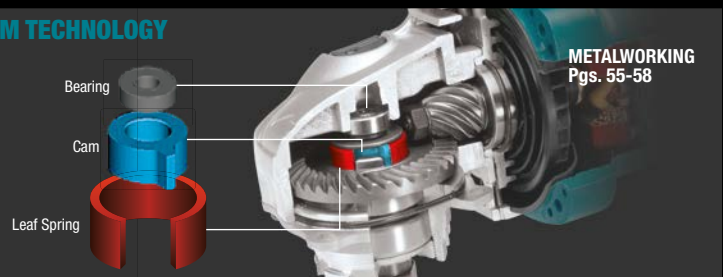

METALWORKING
Pgs. 55-58

Impact GOLD®



**LASTS
10X
LONGER
DOUBLE ENDED
POWER BIT**



**XTREME TORSION
TECHNOLOGY**
for High Torque
Applications

PRECISION-FIT TIP
Prevents "Cam-out"
and Stripping

ACCESSORIES
Pgs. 96-97

LXT BRUSHLESS LITHIUM-ION

3
YEAR
WARRANTY
EXCLUDING TOOL & BATTERY

XPH07M/T/Z*
18v LXT® Brushless 1/2" Hammer Driver-Drill Kit

XFD07M/Z*
18v LXT® Brushless 1/2" Driver-Drill Kit

XPH06/Z*
18v LXT® 1/2" Brushless Hammer Driver-Drill

XDT09M/Z*
18v LXT® Lithium-Ion Brushless Quick-Shift Mode™ 3-Speed Impact Driver

XDT01/Z*
18v LXT® Brushless 3-Speed Impact Driver

XDT08/Z*
18v LXT® Brushless Impact Driver Kit



1,090 In.Lbs. OF AWESOME

1,090 In.Lbs. OF AWESOME

530 In.Lbs. OF MAX TORQUE

MOST RPM IN ITS CLASS

3-SPEED POWER SELECTION FOR PRECISE FASTENING CONTROL

1,420 In.Lbs. OF MAX TORQUE

NEW
XST01M/Z*
18v LXT® Lithium-Ion Brushless Oil-Impulse 3-Speed Impact Driver

NEW
XWT09T/Z*
18v LXT® High Torque 7/16" Hex Impact Wrench Kit

NEW
XWT07M/Z*
18v LXT® High Torque 3/4" Impact Wrench Kit

NEW
XWT08M/Z*
18v LXT® High Torque 1/2" Wrench Kit

XWT02M/Z*
18v LXT® Lithium-Ion Brushless 1/2" 3-Speed Impact Wrench



590 ft.Lbs. OF MAX TORQUE

780 ft.Lbs. OF MAX TORQUE

740 ft.Lbs. OF MAX TORQUE

3-SPEED 210 FT. LBS. OF MAX TORQUE



EXPANDING 18v X2 LXT®



NEW COMING SOON
XRJ06M/Z*
18v X2 LXT® (36v) Recipro Saw



XSH01Z*
18v X2 LXT® (36v) 7-1/4" Circular Saw



XRH05Z*
18v X2 LXT® (36v) 1" Rotary Hammer



NEW
XSL02Z*
18v X2 LXT® (36v) Brushless 7-1/2" Dual Slide Compound Miter Saw



XCU02Z*
18v X2 LXT® (36v) Chain Saw

* "Z" indicates bare tool model. Tool only—does not include battery or charger.

OVER 25 BRUSHLESS TOOLS

DELIVER UP TO 50% LONGER RUN TIME WITH INCREASED POWER & SPEED

XSF03M/Z*
18v LXT® Lithium-Ion Brushless
Drywall Screwdriver



PUSH DRIVE

NEW
XRJ05M/Z*
18v LXT® Brushless Recipro Saw



COMING SOON

XSH03M/Z*
18v LXT® Lithium-Ion
Brushless 6-½" Circular Saw



AUTOMATIC SPEED CHANGE
ADJUSTS SPEED & TORQUE FOR OPTIMUM PERFORMANCE

XVJ02Z*
18v LXT® Lithium-Ion
Brushless Jig Saw



40% FASTER CUTTING
compared to XVJ03

XRU04Z*
18v LXT® Lithium-Ion
Brushless String Trimmer



UP TO 60 MINUTES RUN TIME
with two BL1850 5.0Ah batteries

NEW
XSC02M/Z*
18v LXT® Brushless 5-7/8"
Metal Cutting Saw Kit



AUTOMATIC SPEED CHANGE
ADJUSTS SPEED & TORQUE FOR OPTIMUM PERFORMANCE

NEW
XAG10M/Z* / XAG06MB/Z*
18v LXT® Lithium-Ion Brushless
4-1/2" Cut-Off/Angle Grinder,
Paddle Switch



AUTOMATIC SPEED CHANGE
ADJUSTS SPEED & TORQUE FOR OPTIMUM PERFORMANCE

XAG03MB/Z*
18v LXT® Lithium-Ion Brushless
4-½" Cut-Off/Angle Grinder



AUTOMATIC SPEED CHANGE
ADJUSTS SPEED & TORQUE FOR OPTIMUM PERFORMANCE

XRH011X/XRH01ZVX*
18v LXT® Brushless
1" Rotary Hammer Kit
w/ HEPA Vacuum



BUILT-ON HEPA VACUUM
CAPTURES 99.75% OF PARTICULATES
.3 MICRONS AND LARGER

XRH01Z*
18v LXT® Brushless
1" Rotary Hammer



UP TO 50% MORE RUN TIME
per charge

36v DELIVERS THE POWER & RUN TIME TO UNPLUG THE CORD WITHOUT LEAVING THE 18v LXT® PLATFORM



XBU02Z*
18v X2 LXT® (36v)
Brushless Cordless Blower



XBU01Z*
18v X2 LXT® (36v)
Cordless Blower



XHU04Z*
18v X2 LXT® (36v)
Hedge Trimmer



XRU07Z*
18v X2 LXT® (36v)
Brushless String Trimmer

* "Z" indicates bare tool model. Tool only—does not include battery or charger.



WORLD'S LARGEST 18V™ LITHIUM-ION LINE-UP*

*18v slide-style battery **In 2016





125+
TOOLS**
 SAME BATTERY

LXT
 LITHIUM-ION

LXT
 LITHIUM-ION
BRUSHLESS

BRUSHLESS
18V X2
 36V

COMPACT
 LITHIUM-ION
 18V POWER.



CORDLESS

3
 YEAR
 WARRANTY
 LITHIUM-ION
 TOOL &
 BATTERY

15 – 9-Piece Cordless Combo Kits



- XT1500** 3.0_{ah} BATTERY
- | | |
|-------------------------------------|---|
| XPH01Z 1/2" Hammer Driver-Drill | XSF01Z Drywall Screwdriver |
| XAD01Z 3/8" Angle Drill | XSC01Z 5-3/8" Metal Cutting Saw |
| XDT04Z Impact Driver | DUB182Z Blower |
| XWT05Z 1/2" Impact Wrench | DML184 Fluorescent/Incandescent Flashlight |
| XWT04Z 1/2" Impact Wrench | DML185 Xenon Flashlight |
| XSS02Z 6-1/2" Circular Saw | XRM02W Compact Jobsite Radio |
| XRJ03Z Recipro Saw | BL1830 (4) 18V LXT® Lithium-Ion 3.0Ah Battery |
| XAG01Z 4-1/2" Cut-off/Angle Grinder | DC18RC (2) Rapid Optimum Charger |
| XRH04Z 7/8" Rotary Hammer | |



- XT902** 3.0_{ah} BATTERY
- | | |
|---------------------------------|---|
| XPH01Z 1/2" Hammer Driver-Drill | XAG01Z 4-1/2" Cut-off/Angle Grinder |
| XDT04Z Impact Driver | DML185 Xenon Flashlight |
| XWT05Z 1/2" Impact Wrench | XRM02W Compact Job Site Radio |
| XSS02Z 6-1/2" Circular Saw | BL1830 (2) 18V LXT® Lithium-Ion 3.0Ah Battery |
| XRJ03Z Recipro Saw | DC18RC Rapid Optimum Charger |
| XRH04Z 7/8" Rotary Hammer | |

7 – 4-Piece Cordless Combo Kits



- XT702** 3.0_{ah} BATTERY
- | |
|---|
| XPH01Z 1/2" Hammer Driver-Drill |
| XDT04Z Impact Driver |
| XSS02Z 6-1/2" Circular Saw |
| XRJ03Z Recipro Saw |
| XAG01Z 4-1/2" Cut-off/Angle Grinder |
| DML185 Xenon Flashlight |
| XRM02W Compact Jobsite Radio |
| BL1830 (2) 18V LXT® Lithium-Ion 3.0Ah Battery |
| DC18RC Rapid Optimum Charger |



- XT601** 3.0_{ah} BATTERY
- | |
|---|
| XPH01Z 1/2" Hammer Driver-Drill |
| XDT04Z Impact Driver |
| XSS02Z 6-1/2" Circular Saw |
| XRJ03Z Recipro Saw |
| XAG01Z 4-1/2" Cut-off/Angle Grinder |
| DML185 Xenon Flashlight |
| BL1830 (2) 18V LXT® Lithium-Ion 3.0Ah Battery |
| DC18RC Rapid Optimum Charger |



- NEW XT444MR** 2.0_{ah} BATTERY 4.0_{ah} BATTERY
- | |
|--|
| XPH06Z Brushless Hammer Driver-Drill |
| XDT08Z Brushless Impact Driver |
| XRJ01Z Recipro Saw (Not Brushless) |
| DML802 L.E.D. Flashlight |
| BL1840B 18V LXT® Lithium-Ion 4.0Ah Battery |
| BL1820B 18V LXT® Lithium-Ion 2.0Ah Battery |
| DC18RC Rapid Optimum Charger |



- XT405** 3.0_{ah} BATTERY
- | |
|---|
| XPH01Z 1/2" Hammer Driver-Drill |
| XDT04Z Impact Driver |
| XSS02Z 6-1/2" Circular Saw |
| DML185 Xenon Flashlight |
| BL1830 (2) 18V LXT® Lithium-Ion 3.0Ah Battery |
| DC18RC Rapid Optimum Charger |



- XT406** 3.0_{ah} BATTERY
- | |
|---|
| XPH01Z 1/2" Hammer Driver-Drill |
| XSS02Z 6-1/2" Circular Saw |
| XRJ03Z Recipro Saw |
| DML185 Xenon Flashlight |
| BL1830 (2) 18V LXT® Lithium-Ion 3.0Ah Battery |
| DC18RC Rapid Optimum Charger |



- XT407** 3.0_{ah} BATTERY
- | |
|---|
| XPH01Z 1/2" Hammer Driver-Drill |
| XDT04Z Impact Driver |
| XRJ03Z Recipro Saw |
| DML185 Xenon Flashlight |
| BL1830 (2) 18V LXT® Lithium-Ion 3.0Ah Battery |
| DC18RC Rapid Optimum Charger |



- XT439PMB** 4.0_{ah} BATTERY
- | |
|--|
| XPH07Z Brushless 1/2" Hammer Driver-Drill |
| XDT04Z Impact Driver (Not Brushless) |
| XSH01Z X2 LXT® 7-1/4" Circular Saw (Not Brushless) |
| DML802 LED Flashlight |
| BL1840B (3) 18V LXT® Lithium-Ion 4.0Ah Battery |
| DC18RD Dual Port Rapid Optimum Charger |

2-Piece Cordless Combo Kits



LXT
LITHIUM-ION
BRUSHLESS

XT259PMB

4.0Ah BATTERY

XPH07Z Brushless 1/2" Hammer Driver-Drill
XSH01Z X2 LXT® 7-1/4" Circular Saw (Not Brushless)
BL1840B (3) 18V LXT® Lithium-Ion 4.0Ah Battery
DC18RD Dual Port Rapid Optimum Charger

LXT
LITHIUM-ION
BRUSHLESS

XT258PMB

4.0Ah BATTERY

XDT04Z Impact Driver
XRH05Z X2 LXT® 1" Rotary Hammer
BL1840B (3) 18V LXT® Lithium-Ion 4.0Ah Battery
DC18RD Dual Port Rapid Optimum Charger

LXT
LITHIUM-ION
BRUSHLESS

XT252TB

5.0Ah BATTERY

XPH07Z Brushless 1/2" Hammer Driver-Drill
XDT01Z Brushless 3-Speed Impact Driver
BL1850B (2) 18V LXT® Lithium-Ion 5.0Ah Battery
DC18RC Rapid Optimum Charger

LXT
LITHIUM-ION
BRUSHLESS

XT252MB

4.0Ah BATTERY

XPH07Z Brushless 1/2" Hammer Driver-Drill
XDT01Z Brushless 3-Speed Impact Driver
BL1840B (2) 18V LXT® Lithium-Ion 4.0Ah Battery
DC18RC Rapid Optimum Charger



LXT
LITHIUM-ION
BRUSHLESS

XT257TB

5.0Ah BATTERY

XPH07Z Brushless 1/2" Hammer Driver-Drill
XDT08Z Brushless Impact Driver
BL1850B (2) 18V LXT® Lithium-Ion 5.0Ah Battery
DC18RC Rapid Optimum Charger

LXT
LITHIUM-ION
BRUSHLESS

XT257MB

4.0Ah BATTERY

XPH07Z Brushless 1/2" Hammer Driver-Drill
XDT08Z Brushless Impact Driver
BL1840B (2) 18V LXT® Lithium-Ion 4.0Ah Battery
DC18RC Rapid Optimum Charger

LXT
LITHIUM-ION
BRUSHLESS

XT248MB

4.0Ah BATTERY

XPH06Z Brushless Hammer Driver-Drill
XDT08Z Brushless Impact Driver
BL1840B (2) 18V LXT® Lithium-Ion 4.0Ah Battery
DC18RC Rapid Optimum Charger

LXT
LITHIUM-ION
BRUSHLESS

XT248

3.0Ah BATTERY

XPH06Z Brushless Hammer Driver-Drill
XDT08Z Brushless Impact Driver
BL1830 (2) 18V LXT® Lithium-Ion 3.0Ah Battery
DC18RC Rapid Optimum Charger



COMPACT
LITHIUM-ION
18V POWER
BRUSHLESS

NEW XT248R

2.0Ah BATTERY

XPH06Z Brushless Hammer Driver-Drill
XDT08Z Brushless Impact Driver
BL1820B (2) 18V Compact Lithium-Ion 2.0Ah Battery
DC18RC Rapid Optimum Charger

LXT
LITHIUM-ION
BRUSHLESS

XT255MB

4.0Ah BATTERY

XSF03Z Brushless Drywall Screwdriver
XOC01Z Cut-Out Tool (Not Brushless)
BL1840B (2) 18V LXT® Lithium-Ion 4.0Ah Battery
DC18RC Rapid Optimum Charger

LXT
LITHIUM-ION
BRUSHLESS

XT256MB

4.0Ah BATTERY

XDT04Z Impact Driver (Not Brushless)
XSF03Z Brushless Drywall Screwdriver
BL1840B (2) 18V LXT® Lithium-Ion 4.0Ah Battery
DC18RC Rapid Optimum Charger

LXT
LITHIUM-ION
BRUSHLESS

XT249

3.0Ah BATTERY

XDT04Z Impact Driver
XSF01Z Drywall Screwdriver
BL1830 (2) 18V LXT® Lithium-Ion 3.0Ah Battery
DC18RC Rapid Optimum Charger

LXT
LITHIUM-ION
BRUSHLESS

XT221

3.0Ah BATTERY

XPH03Z 1/2" Hammer Driver Drill
XRJ03Z Recipro Saw
BL1830 (2) 18V LXT® Lithium-Ion 3.0Ah Battery
DC18RC Rapid Optimum Charger



LXT
LITHIUM-ION
BRUSHLESS

XT218

3.0Ah BATTERY

XPH03Z 1/2" Hammer Driver Drill
XDT04Z Impact Driver
BL1830 (2) 18V LXT® Lithium-Ion 3.0Ah Battery
DC18RC Rapid Optimum Charger

LXT
LITHIUM-ION
BRUSHLESS

XT218MB

4.0Ah BATTERY

XPH03Z 1/2" Hammer Driver Drill
XDT04Z Impact Driver
BL1840B (2) 18V LXT® Lithium-Ion 4.0Ah Battery
DC18RC Rapid Optimum Charger

LXT
LITHIUM-ION
BRUSHLESS

XT211

3.0Ah BATTERY

XPH01Z 1/2" Hammer Driver-Drill
XDT04Z Impact Driver
BL1830 (2) 18V LXT® Lithium-Ion 3.0Ah Battery
DC18RC Rapid Optimum Charger

LXT
LITHIUM-ION
BRUSHLESS

XT211MB

4.0Ah BATTERY

XPH01Z 1/2" Hammer Driver-Drill
XDT04Z Impact Driver
BL1840B (2) 18V LXT® Lithium-Ion 4.0Ah Battery
DC18RC Rapid Optimum Charger

LXT
LITHIUM-ION
BRUSHLESS

XT211A

3.0Ah BATTERY

XPH01Z 1/2" Hammer Driver-Drill
XDT04Z Impact Driver
BL1830 (2) 18V LXT® Lithium-Ion 3.0Ah Battery
DC18SE Optimum Automotive Charger

UPGRADE YOUR 18v KIT

1,090 IN.LBS. OF AWESOME

5.0Ah BATTERY



NEW BL1850B

AVAILABLE ON 18v CORDLESS TOOL MODEL #'S ENDING WITH **"TB" or "T"**

4.0Ah BATTERY



NEW BL1840B

AVAILABLE ON 18v CORDLESS TOOL MODEL #'S ENDING WITH **"MB" or "M"**

2.0Ah BATTERY



NEW BL1820B

COMPATIBLE ONLY WITH 18v STAR PROTECTION TOOLS



UPGRADED

NEW L.E.D. BATTERY CHARGE INDICATOR



XPH07TB / XPH07MB

18v LXT® BRUSHLESS 1/2" HAMMER DRIVER-DRILL KIT Delivers Up To 50% More Power and Performance¹

- BL™ Brushless Motor delivers 1,090 in.lbs. of Max Torque
- 0-31,500 BPM for fast hammer drilling in masonry materials
- Efficient BL™ Brushless motor is electronically controlled to optimize battery energy use for up to 50% longer run time per charge
- The BL™ Brushless Motor eliminates carbon brushes, enabling the BL™ Motor to run cooler and more efficiently for longer life
- The electronically-controlled BL™ Brushless Motor efficiently uses energy to match torque and RPM to the changing demands of the application

¹ Compared to LXP403



XPH07TB shown



Model XPH07TB Includes: (2) 18V LXT® Lithium-Ion 5.0Ah Battery (BL1850B), 18V Lithium-Ion Rapid Optimum Charger (DC18RC), Side Handle (126413-8), Depth Gauge (122576-8), Belt Clip (346317-0), Tool Case

Model XPH07MB Includes: Same as XPH07TB except (2) 18V LXT® Lithium-Ion 4.0Ah Battery (BL1840B)

Model XPH07Z Includes: Tool Only; Battery and Charger not included

Capacities:	Steel (1/2"), Wood (3"), Masonry (5/8")
No Load Speed (var. 2 spd)	0 - 550 / 0 - 2,100 RPM
Blows Per Minute (2 speed)	0 - 8,250 / 0 - 31,500 BPM
Maximum Torque (in.lbs./N•m)	1,090 in.lbs./125N•m
Battery	18V LXT® Lithium-Ion
Overall Length	8-1/8"
Net Weight (with battery)	5.9 lbs.
Shipping Weight	XPH07TB (16.12 lbs.), XPH07MB (16.45 lbs.)

UP TO **77 HOLES** IN A SINGLE CHARGE²

² Using BL1840 4.0Ah battery



XPH07M

HOLES 10 20 30 40 50 60 70 80

UP TO **24%** FASTER DRILLING³

Time to drill 3 holes using 2-9/16" self-feed bit



[Learn More](http://makitatools.com/Awesome) makitatools.com/Awesome

³ Data on XFD07M/XPH07T based on Makita® testing compared to leading competitors

COMPACT HAMMER-DRILL



XPH10Z

POWER

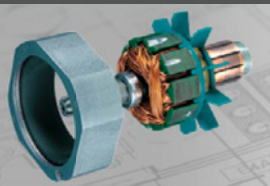

Makita-built 4-pole motor delivers 480 in.lbs. of Max Torque



NEW XPH10R

18v COMPACT 1/2" HAMMER DRIVER-DRILL KIT More Compact And 26% More RPM⁴

- Makita-built 4-pole motor delivers 480 in.lbs. of Max Torque
- Variable 2-speed design (0-600 & 0-1,900 RPM) covers a wide range of drilling, driving and hammer applications
- Compact and ergonomic design at only 7-3/4" long
- Weighs only 3.4 lbs. with battery for reduced operator fatigue
- Rubberized soft grip provides increased comfort on the job
- Dual L.E.D. lights with afterglow illuminate the work area

⁴ Compared to XPH01Z

Model XPH10R Includes: (2) 18V Compact Lithium-Ion 2.0Ah Battery (BL1820B), 18V Lithium-Ion Rapid Optimum Charger (DC18RC), Tool Case, Belt Clip

Model XPH10Z Includes: Tool Only; Battery and Charger not included

Capacities:	Steel (1/2"), Wood (1-1/2"), Masonry (1/2")
No Load Speed (var. 2 spd)	0 - 600 / 0 - 1,900 RPM
Blows Per Minute (2 speed)	0 - 9,000 / 0 - 28,500 BPM
Maximum Torque (in.lbs./N•m)	480 in.lbs./54N•m
Battery	18V Compact Lithium-Ion
Overall Length	7-3/4"
Net Weight (with battery)	3.4 lbs.
Shipping Weight	10.7 lbs.



XPH06Z



XPH06



18v LXT® 1/2" BRUSHLESS HAMMER DRIVER-DRILL KIT Delivers 35% More Drilling, Driving and Fastening Speed⁴

- BL™ Brushless Motor delivers 530 in.lbs. of Max Torque
- Variable 2-speed (0-400 & 0-1,550 RPM) for a wide range of drilling, fastening and hammer drilling applications
- Efficient BL™ Brushless motor is electronically controlled to optimize battery energy use for up to 50% longer run time per charge
- The BL™ Brushless Motor eliminates carbon brushes, enabling the BL™ Motor to run cooler and more efficiently for longer life

Model XPH06 Includes: 18V Lithium-Ion Rapid Optimum Charger (DC18RC), (2) 18V LXT® Lithium-Ion 3.0Ah Battery (BL1830), Tool Case

Model XPH06Z Includes: Tool Only; Battery and Charger not included

Capacities:	Steel (1/2"), Wood (1-1/2"), Masonry (1/2")
No Load Speed (var. 2 spd)	0 - 400 / 0 - 1,550 RPM
Blows Per Minute (2 speed)	0 - 6,000 / 0 - 23,000 BPM
Maximum Torque (in.lbs./N•m)	530 in.lbs./45N•m
Battery	18V LXT® Lithium-Ion
Overall Length	7-7/8"
Net Weight (with battery)	5.9 lbs.
Shipping Weight	10.8 lbs.

⁵ Compared to LXP405



18v LXT® BRUSHLESS 3-SPEED IMPACT DRIVER KIT
High Performance with Brushless Motor

- Quick-Shift Mode™ selector has an automatic controller that downshifts and reduces rotation and impact speed prior to driving screw into place
- BL™ Brushless Motor delivers 3,600 Max RPM and 1,550 in.lbs. of Max Torque
- Features Extreme Protection Technology (XPT™) which is engineered to provide increased dust and water resistance in harsh job site conditions

Model XDT09MB Includes: (2) 18V LXT® Lithium-Ion 4.0Ah Battery (BL1840B), 18V Lithium-Ion Rapid Optimum Charger (DC18RC), Tool Case
Model XDT09Z Includes: Tool Only; Battery and Charger not included

Hex Shank	1/4"
Impacts Per Minute (3 speed)	0 - 1,100 / 0 - 2,600 / 0 - 3,800 IPM
No Load Speed (3 speed)	0 - 1,100 / 0 - 2,100 / 0 - 3,600 RPM
Maximum Torque (in.lbs./N•m)	1,550 in.lbs./175N•m
Battery	18V LXT® Lithium-Ion
Overall Length	4-11/16"
Net Weight (with battery)	3.3 lbs.
Shipping Weight	10.8 lbs.



18v LXT® BRUSHLESS 3-SPEED IMPACT DRIVER KIT
3-Speed Power Selection for Precise Fastening Control

- Efficient BL™ Brushless motor is electronically controlled to optimize battery energy use for up to 50% longer run time per charge
- Makita-built Brushless Motor delivers 1,460 in.lbs. of Max Torque
- 3-speeds (0-1,300, 0-2,000, 0-2,600 RPM & 0-1,300, 0-2,000 / 2,600 IPM) for a wide range of applications
- Compact and ergonomic design at only 5-1/2" long

Model XDT01 Includes: (2) 18V LXT® Lithium-Ion 3.0Ah Battery (BL1830), 18V Lithium-Ion Rapid Optimum Charger (DC18RC), Tool Case
Model XDT01Z Includes: Tool Only; Battery and Charger not included

Hex Shank	1/4"
No Load Speed (3 speed)	0 - 1,300 / 0 - 2,000 / 0 - 2,600 RPM
Impacts Per Minute (3 speed)	0 - 1,300 / 0 - 2,800 / 0 - 3,400 IPM
Maximum Torque (in.lbs./N•m)	1,460 in.lbs./165N•m
Battery	18V LXT® Lithium-Ion
Overall Length	5-1/2"
Net Weight (with battery)	2.8 lbs.
Shipping Weight	10.3 lbs.



POWER
Makita 4-pole motor with innovative 4-brush design delivers 26% more RPM without decreasing torque¹



DESIGN
Dual L.E.D. lights with afterglow illuminate the work area



DURABILITY
All-metal gear housing



18v LXT® BRUSHLESS IMPACT DRIVER KIT
Brushless Motor Delivers up to 50% Longer Run Time Per Charge

- The BL™ Brushless Motor eliminates carbon brushes, enabling the BL™ Motor to run cooler and more efficiently for longer life
- BL™ Brushless Motor delivers 1,420 in.lbs. of Max Torque
- Variable speed (0-2,500 RPM & 0-3,200 IPM) for a wide range of fastening applications
- 18V LXT® Lithium-Ion battery charges in only 30 minutes

Model XDT08 Includes: (2) 18V LXT® Lithium-Ion 3.0Ah Battery (BL1830), 18V Lithium-Ion Rapid Optimum Charger (DC18RC), Tool Case
Model XDT08Z Includes: Tool Only; Battery and Charger not included

Hex Shank	1/4"
No Load Speed (variable speed)	0 - 2,500 RPM
Impacts Per Minute (variable speed)	0 - 3,200 IPM
Maximum Torque (in.lbs./N•m)	1,420 in.lbs./160N•m
Battery	18V LXT® Lithium-Ion
Overall Length	5-7/8"
Net Weight (with battery)	3.4 lbs.
Shipping Weight	11 lbs.



18v COMPACT IMPACT DRIVER KIT
Makita 4-Pole Motor with 4-Brush Design Delivers 26% More RPM without Decreasing Torque¹

- Variable speed (0-2,900 RPM & 0-3,500 IPM) and 1,460 in.lbs. of torque for a wide range of fastening applications
- All metal gear housing for increased job site durability
- Compact and ergonomic design at only 5-3/8" long
- Weighs only 2.8 lbs. with battery for reduced operator fatigue
- Convenient one-touch 1/4" hex chuck for quick bit changes
- Only use genuine Makita batteries and chargers

Model XDT11R Includes: (2) 18V Compact Lithium-Ion 2.0Ah Battery (BL1820B), 18V Lithium-Ion Rapid Optimum Charger (DC18RC), Tool Case
Model XDT11Z Includes: Tool Only; Battery and Charger not included



18v LXT® IMPACT DRIVER KIT
Makita-Built 4-Pole Motor Delivers Industrial Fastening Power in a Compact Size

- Variable speed (0-2,300 RPM & 0-3,200 IPM) for a wide range of fastening applications
- Convenient one-touch 1/4" hex chuck for quick bit changes
- Makita-built 4-pole motor delivers 1,420 in.lbs. of Max Torque
- Rubberized soft grip provides increased comfort on the job
- Makita-built 4-pole motor delivers 1,420 in.lbs. of Max Torque

Model XDT04 Includes: (2) 18V LXT® Lithium-Ion 3.0Ah Battery (BL1830), 18V Lithium-Ion Rapid Optimum Charger (DC18RC), Tool Case
Model XDT04Z Includes: Tool Only; Battery and Charger not included

Hex Shank	1/4"
No Load Speed (variable speed)	0 - 2,300 RPM
Impacts Per Minute (variable speed)	0 - 3,200 IPM
Maximum Torque (in.lbs./N•m)	1,420 in.lbs./160N•m
Battery	18V LXT® Lithium-Ion
Overall Length	5-7/16"
Net Weight (with battery)	3.3 lbs.
Shipping Weight	12 lbs.



18v LXT® HYBRID™ IMPACT DRIVER KIT
4 Tools in 1

- Hybrid 4-function tool with impact, hammer, driver and drill all in one
- Variable 2-speed (0-700 & 0-2,300 RPM) for a wide range of drilling, driving and fastening applications
- Makita-built 4-pole motor delivers 1,240 in.lbs. of impact Max Torque
- Convenient 1/4" hex chuck for quick bit changes
- Compact and ergonomic design at only 7-3/8" long
- Weighs only 4.1 lbs. with battery for reduced operator fatigue

Model XPT03 Includes: (2) 18V LXT® Lithium-Ion 3.0Ah Battery (BL1830), 18V Lithium-Ion Rapid Optimum Charger (DC18RC), Tool Bag
Model XPT03Z Includes: Tool Only; Battery and Charger not included

Hex Shank	1/4"
No Load Speed (var. 2 spd)	0 - 700 / 0 - 2,300 RPM
Impacts Per Minute (variable speed)	0 - 3,200 IPM
Maximum Torque (in.lbs./N•m)	1,240 in.lbs./140N•m
Blows Per Minute (variable speed)	0 - 27,600 BPM
Battery	18V LXT® Lithium-Ion
Overall Length	7-3/8"
Net Weight (with battery)	4.1 lbs.
Shipping Weight	11.7 lbs.

¹ Compared to XDT04Z



Z
Z-TOOL
Z-TOOL
Z-TOOL
Z-TOOL
XST01Z

18v LXT® BRUSHLESS 3-SPEED IMPACT DRIVER KIT
Up to 30% Lower Noise for Quiet Operation²

- Oil-Impulse™ Technology utilizes oil to hydraulically drive the impact mechanism for lower noise and increased efficiency
- Quick-Shift Mode™ selector has an automatic electronic controller that downshifts and reduces rotation and impact speed prior to driving screw
- The BL™ Brushless Motor eliminates carbon brushes, enabling the BL™ Motor to run cooler and more efficiently for longer life

Model XST01M Includes: (2) 18V LXT® Lithium-Ion 4.0Ah Battery (BL1840B), 18V Lithium-Ion Rapid Optimum Charger (DC18RC), Belt Clip (346449-3), Tool case,

Model XST01Z Includes: Tool Only; Battery and Charger not included

Hex Shank	1/4"
Impacts Per Minute (3 speed)	0 - 2,700 / 0 - 2,200 / 0 - 1,400 IPM
No Load Speed (3 speed)	0 - 3,200 / 0 - 2,000 / 0 - 1,200 RPM
Maximum Torque (in.lbs./N•m)	355 in.lbs./40N•m
Battery	18V LXT® Lithium-Ion
Net Weight (with battery)	3.2 lbs.
Shipping Weight	12 lbs.

²In lowest speed setting



Z
Z-TOOL
Z-TOOL
Z-TOOL
Z-TOOL
XLT01Z

18v LXT® ANGLE IMPACT DRIVER KIT
Ideal for Fastening in Close Quarters

- Makita-built motor delivers 530 in.lbs. of Max Torque
- Variable speed (0-2,000 RPM & 0-3,000 IPM) for a wide range of fastening applications
- Compact 2-1/8" angle head height for use in close quarters
- Large paddle switch with soft grip provides increased comfort
- Long, ergonomic body design provides maximum reach

Model XLT01 Includes: (2) 18V LXT® Lithium-Ion 3.0Ah Battery (BL1830), 18V Lithium-Ion Rapid Optimum Charger (DC18RC), #2 Phillips Double Ended Bit (784202-3), Tool Bag

Model XLT01Z Includes: Tool Only; Battery and Charger not included

Hex Shank	1/4"
Impacts Per Minute (variable speed)	0 - 3,000 IPM
No Load Speed (variable speed)	0 - 2,000 RPM
Maximum Torque (in.lbs./N•m)	530 in.lbs./60N•m
Battery	18V LXT® Lithium-Ion
Overall Length	15-1/4"
Net Weight (with battery)	3.9 lbs.
Shipping Weight	11.5 lbs.

740 FT.LBS. OF TORQUE

Z
Z-TOOL
Z-TOOL
Z-TOOL
Z-TOOL
XWT08Z



18v LXT® BRUSHLESS HIGH TORQUE 1/2" IMPACT WRENCH KIT
Perfect for High Torque Fastening Applications

- BL™ Motor delivers 740 ft.lbs. of Max Torque and 1,180 ft.lbs. of breakaway torque
- 3-speed (0-900 / 0-1,000 / 0-1,800 RPM & 0-1,800 / 0-2,000 / 0-2,200 IPM) for precise fastening control
- Compact and ergonomic design at only 9" long
- 1/2" anvil with friction ring for quick and easy socket changes
- The BL™ Brushless Motor eliminates carbon brushes, enabling the BL™ Motor to run cooler and more efficiently for longer life

Model XWT08M Includes: (2) 18V LXT® Lithium-Ion 4.0Ah Battery (BL1840B), 18V Lithium-Ion Rapid Optimum Charger (DC18RC), Tool Bag

Model XWT08Z Includes: Tool Only; Battery and Charger not included

Square Drive	1/2"
No Load Speed (3 speed)	0 - 900 / 0 - 1,000 / 0 - 1,800 RPM
Impacts Per Minute (3 speed)	0 - 1,800 / 0 - 2,000 / 0 - 2,200 IPM
Maximum Torque (ft.lbs.)	740 ft.lbs.
Battery	18V LXT® Lithium-Ion
Overall Length	9"
Net Weight (with battery)	7.9 lbs.
Shipping Weight	16.2 lbs.



Z
Z-TOOL
Z-TOOL
Z-TOOL
Z-TOOL
XWT07Z

18v LXT® BRUSHLESS HIGH TORQUE 3/4" IMPACT WRENCH KIT
Perfect for High Torque Fastening Applications

- BL™ Motor delivers 780 ft.lbs. of Max Torque and 1,250 ft.lbs. of breakaway torque
- 3-speed power selection switch (0-900 / 0-1,000 / 0-1,800 RPM & 0-1,800 / 0-2,000 / 0-2,200 IPM) provides precise fastening control
- 3/4" anvil with friction ring and thru hole retention system for maximum productivity

Model XWT07M Includes: (2) 18V LXT® Lithium-Ion 4.0Ah Battery (BL1840B), 18V Lithium-Ion Rapid Optimum Charger (DC18RC), Tool Bag

Model XWT07Z Includes: Tool Only; Battery and Charger not included

Square Drive	3/4"
No Load Speed (3 speed)	0 - 900 / 0 - 1,000 / 0 - 1,800 RPM
Impacts Per Minute (3 speed)	0 - 1,800 / 0 - 2,000 / 0 - 2,200 IPM
Maximum Torque (ft.lbs.)	780 ft.lbs.
Battery	18V LXT® Lithium-Ion
Overall Length	9"
Net Weight (with battery)	8.1 lbs.
Shipping Weight	16.6 lbs.



Z
Z-TOOL
Z-TOOL
Z-TOOL
Z-TOOL
XWT09Z

18v LXT® BRUSHLESS HIGH TORQUE 7/16" HEX IMPACT WRENCH KIT
Perfect for High Torque Drilling Applications

- BL™ Motor delivers 590 ft.lbs. of Max Torque
- 3-speed power selection switch (0-900 / 0-1,000 / 0-1,800 RPM & 0-1,800 / 0-2,000 / 0-2,200 IPM) provides the user with precise fastening control
- The BL™ Brushless Motor eliminates carbon brushes, enabling the BL™ Motor to run cooler and more efficiently for longer life
- Efficient BL™ Brushless motor is electronically controlled to optimize battery energy use for up to 50% longer run time per charge

Model XWT09T Includes: 18V LXT® Lithium-Ion 5.0Ah Battery (BL1850B), 18V Lithium-Ion Rapid Optimum Charger (DC18RC), Tool Bag

Model XWT09Z Includes: Tool Only; Battery and Charger not included

Hex Shank	7/16"
No Load Speed (3 speed)	0 - 900 / 0 - 1,000 / 0 - 1,800 RPM
Impacts Per Minute (3 speed)	0 - 1,800 / 0 - 2,000 / 0 - 2,200 IPM
Maximum Torque (ft.lbs.)	590 ft.lbs.
Battery	18V LXT® Lithium-Ion
Overall Length	9"
Net Weight (with battery)	8.1 lbs.
Shipping Weight	16.7 lbs.



Z
Z-TOOL
Z-TOOL
Z-TOOL
Z-TOOL
XWT04Z

18v LXT® 1/2" IMPACT WRENCH KIT
1/2" Sq. Drive Designed for Faster and Convenient Fastening

- Makita-built Makita-built motor delivers 325 ft.lbs. of Max Torque, with 1,600 RPM and 2,200 IPM for superior fastening power
- Shock absorbent handle protects battery housing for extra durability
- Rocker switch for forward/reverse operation
- Rubberized soft grip handle provides increased comfort on the job
- Compact and ergonomic design at only 10-1/2" long

Model XWT04MB Includes: (2) 18V LXT® Lithium-Ion 4.0Ah Battery (BL1840B), 18V Lithium-Ion Rapid Optimum Charger (DC18RC), Tool Bag

Model XWT04Z Includes: Tool Only; Battery and Charger not included

Square Drive	1/2"
No Load Speed	1,600 RPM
Impacts Per Minute	2,200 IPM
Maximum Torque (ft.lbs./N•m)	325 ft.lbs./440 N•m
Battery	18V LXT® Lithium-Ion
Overall Length	10-1/2"
Net Weight (with battery)	4.9 lbs.
Shipping Weight	16 lbs.



Z
Z-TOOL
Z-TOOL
Z-TOOL
Z-TOOL
XWT01Z

18v LXT® 7/16" IMPACT WRENCH KIT
Quick Change 7/16" Hex Chuck Designed for Electric Power and Telephone Utility Companies

- Engineered for drilling and fastening into treated wood utility poles without rotational torque to help maintain balance
- Makita-built motor delivers 325 ft.lbs. of Max Torque, with 1,900 RPM and 2,200 IPM for powerful drilling and fastening
- Rocker switch for forward/reverse operation

Model XWT01 Includes: (2) 18V LXT® Lithium-Ion 3.0Ah Battery (BL1830), 18V Lithium-Ion Rapid Optimum Charger (DC18RC), Tool Bag

Model XWT01Z Includes: Tool Only; Battery and Charger not included

Hex Shank	7/16"
No Load Speed	1,900 RPM
Impacts Per Minute	2,200 IPM
Maximum Torque (ft.lbs./N•m)	325 ft.lbs./440 N•m
Battery	18V LXT® Lithium-Ion
Overall Length	10-3/4"
Net Weight (with battery)	7.8 lbs.
Shipping Weight	16.4 lbs.

XWT02Z

BRUSHLESS

XWT02MB

XPT™

4.0Ah BATTERY

18v LXT® BRUSHLESS 3-SPEED 1/2" IMPACT WRENCH KIT
Improved Fastening Control

- BL™ Brushless Motor delivers 210 ft.lbs. of Max Torque
- Compact and ergonomic design at only 5-3/4" long
- 3-speed power selection switch (0-1,600 / 0-2,100 / 0-2,800 RPM & 0-1,800 / 0-2,600 / 0-3,500 IPM) for precise fastening control
- Efficient BL™ Brushless Motor is electronically controlled to optimize battery energy use for up to 50% longer run time per charge

Model XWT02MB Includes: (2) 18V LXT® Lithium-Ion 4.0Ah Battery (BL1840B), 18V Lithium-Ion Rapid Optimum Charger (DC18RC), Tool Bag

Model XWT02Z Includes: Tool Only; Battery and Charger not included

Square Drive	1/2"
No Load Speed (3 speed)	0 - 1,600 / 0 - 2,100 / 0 - 2,800 RPM
Impacts Per Minute (3 speed)	0 - 1,800 / 0 - 2,600 / 0 - 3,500 IPM
Maximum Torque (ft.lbs./N•m)	210 ft.lbs./280 N•m
Battery	18V LXT® Lithium-Ion
Overall Length	5-3/4"
Net Weight (with battery)	3.8 lbs.
Shipping Weight	12 lbs.

XWT05Z

LXT

XWT05

3.0Ah BATTERY

18v LXT® 1/2" IMPACT WRENCH KIT
Great for Mechanics, Installers & Builders

- Makita-built 4-pole motor delivers 170 ft.lbs. of Max Torque
- 0-2,100 RPM & 0-3,200 IPM for a wide range of fastening applications
- Compact and ergonomic design at only 6-1/2" long
- Built-in L.E.D. light illuminates the work area
- Ergonomic shape fits like a glove with even pressure and easy control

Model XWT05 Includes: (2) 18V LXT® Lithium-Ion 3.0Ah Battery (BL1830), 18V Lithium-Ion Rapid Optimum Charger (DC18RC), Tool Bag

Model XWT05Z Includes: Tool Only; Battery and Charger not included

Square Drive	1/2"
No Load Speed (variable speed)	0 - 2,100 RPM
Impacts Per Minute (variable speed)	0 - 3,200 IPM
Maximum Torque (ft.lbs./N•m)	170 ft.lbs./230 N•m
Battery	18V LXT® Lithium-Ion
Overall Length	6-1/2"
Net Weight (with battery)	3.8 lbs.
Shipping Weight	11.15 lbs.

XWT06Z

LXT

XWT06

3.0Ah BATTERY

18v LXT® 3/8" IMPACT WRENCH KIT
Perfect for Automotive Mechanics

- Makita-built 4-pole motor delivers 155 ft.lbs. of Max Torque
- Variable speed (0-2,100 RPM & 0-3,200 IPM) for a wide range of fastening applications
- Compact and ergonomic design at only 6-1/8" long
- Rubberized soft grip handle provides increased comfort on the job
- Built-in L.E.D. light with afterglow illuminates the work area

Model XWT06 Includes: 18V LXT® Lithium-Ion 3.0Ah Battery (BL1830), 18V Lithium-Ion Rapid Optimum Charger (DC18RC), Tool Bag

Model XWT06Z Includes: Tool Only; Battery and Charger not included

Square Drive	3/8"
No Load Speed (variable speed)	0 - 2,100 RPM
Impacts Per Minute (variable speed)	0 - 3,200 IPM
Maximum Torque (ft.lbs./N•m)	155 ft.lbs./210 N•m
Battery	18V LXT® Lithium-Ion
Overall Length	6-1/8"
Net Weight (with battery)	3.4 lbs.
Shipping Weight	9.3 lbs.

XLT02Z

LXT

XLT02

3.0Ah BATTERY

18v LXT® 3/8" ANGLE IMPACT WRENCH KIT
3/8" Angle Wrench for Work in Tight Spaces

- Makita-built motor delivers 44 ft.lbs. of Max Torque
- Variable speed (0-2,000 RPM & 0-3,000 IPM) for a wide range of fastening applications
- Compact 2-1/4" angle head height for use in close quarters
- Long, ergonomic body design provides maximum reach
- Large conveniently located paddle switch for comfortable operation

Model XLT02 Includes: (2) 18V LXT® Lithium-Ion 3.0Ah Battery (BL1830), 18V Lithium-Ion Rapid Optimum Charger (DC18RC), Tool Bag

Model XLT02Z Includes: Tool Only; Battery and Charger not included

Square Drive	3/8"
No Load Speed (variable speed)	0 - 2,000 RPM
Impacts Per Minute (variable speed)	0 - 3,000 IPM
Maximum Torque (ft.lbs./N•m)	44 ft.lbs./60 N•m
Battery	18V LXT® Lithium-Ion
Overall Length	15-1/4"
Net Weight (with battery)	3.3 lbs.
Shipping Weight	11.3 lbs.

SAWS

THE NEW 7-1/4" INDUSTRY STANDARD

XSH01Z

BRUSHLESS

XSH01X

3.0Ah BATTERY

18v X2 LXT® (36v) 7-1/4" CIRCULAR SAW KIT

Two 18V LXT® Batteries Deliver the Cutting Performance of a Corded Saw¹

- Makita-built motor delivers 4,800 RPM for fast cutting and ripping
- Two 18V LXT® Lithium-Ion batteries deliver up to 2.5X more cuts per charge²
- Large cutting capacity (2-5/8" at 90°) and bevel capacity (0°-50°) with a positive stop at 45°
- Reinforced magnesium base for durability
- Weighs only 10.1 lbs. with batteries for operator comfort

Model XSH01X Includes: (2) 18V LXT® Lithium-Ion 3.0Ah Battery (BL1830), 18V Lithium-Ion Rapid Optimum Charger (DC18RC), 7-1/4" 24T Ultra-Coated C.T. Saw Blade (A-94530-A), Tool Bag

Model XSH01Z Includes: Tool Only; Battery and Charger not included

Blade Diameter	7-1/4"
Arbor	5/8"
Max. Cutting Capacity:	90° (2-5/8"), 45° (1-7/8"), 50° (1-11/16")
No Load Speed	4,800 RPM
Battery	2X 18V LXT® Lithium-Ion
Overall Length	14"
Net Weight (with battery)	10.1 lbs.
Shipping Weight	19.3 lbs.

XSH03Z

BRUSHLESS

AUTOMATIC SPEED CHANGE™

XSH03MB

4.0Ah BATTERY

18v LXT® BRUSHLESS 6-1/2" CIRCULAR SAW KIT
Automatic Speed Change™ Technology

- BL™ Motor delivers 5,000 RPM for faster cutting and ripping
- Automatic Speed Change™ technology adjusts speed and torque during operation for optimum performance
- Compact and ergonomic design at only 13-3/4" long
- Weighs only 7.3 lbs. with battery for reduced operator fatigue
- Large cutting capacity (2-1/4" at 90°) and bevel capacity (0°-50°)

Model XSH03MB Includes: (2) 18V LXT® Lithium-Ion 4.0Ah Battery (BL1840B), 18V Lithium-Ion Rapid Optimum Charger (DC18RC), 6-1/2" 24T C.T. Saw Blade (A-85092), Tool Bag

Model XSH03Z Includes: Tool Only; Battery and Charger not included

Blade Diameter	6-1/2"
Arbor	5/8"
Max. Cutting Capacity:	90° (2-1/4"), 45° (1-5/8"), 50° (1-7/16")
No Load Speed	5,000 RPM
Battery	18V LXT® Lithium-Ion
Overall Length	13-3/4"
Net Weight (with battery)	7.3 lbs.
Shipping Weight	16 lbs.

XSS01Z

LXT

XSS01

3.0Ah BATTERY

18v LXT® 6-1/2" CIRCULAR SAW KIT
Cuts 2X Material at 45°

- Makita-built motor delivers 3,700 RPM for faster cutting and ripping through wood
- Built-in L.E.D. light illuminates the work area
- 50° maximum bevel cutting capacity
- Built-in dust blower keeps the line of cut free of debris for more accurate cuts
- Heavy gauge, precision machined base for smooth, accurate cutting and added durability

Model XSS01 Includes: (2) 18V LXT® Lithium-Ion 3.0Ah Battery (BL1830), 18V Lithium-Ion Rapid Optimum Charger (DC18RC), 6-1/2" 24T C.T. Saw Blade (A-85092), Tool Case

Model XSS01Z Includes: Tool Only; Battery and Charger not included

Blade Diameter	6-1/2"
Arbor	5/8"
Max. Cutting Capacity:	90° (2-1/4"), 45° (1-9/16")
No Load Speed	3,700 RPM
Battery	18V LXT® Lithium-Ion
Overall Length	13-5/8"
Net Weight (with battery)	7.6 lbs.
Shipping Weight	17.5 lbs.

¹ Compared to Makita 5007 Series

² Compared to Makita BSS611Z



XSS02Z

Tool only - battery and charger not included

18v LXT® 6-1/2" CIRCULAR SAW
2-1/4" Maximum Cutting Capacity

- Makita-built motor delivers 3,700 RPM for faster cutting
- Heavy gauge machined base for smooth and accurate cutting
- 50° maximum bevel cutting capacity
- Weighs only 7.3 lbs. with battery (battery not included) for reduced operator fatigue
- Rubberized soft grip handle provides increased comfort on the job

Model XSS02Z Includes: Tool Only - TCT Saw Blade 165x15.88x16T (A-96023)

Blade Diameter	6-1/2"
Arbor	5/8"
Max. Cutting Capacity:	90° (2-1/4"), 45° (1-9/16")
No Load Speed	3,700 RPM
Battery	18V LXT® Lithium-Ion
Overall Length	13-5/8"
Net Weight (with battery)	7.3 lbs.
Shipping Weight	7.5 lbs.



XSS03



3.0Ah BATTERY

18v LXT® 5-3/8" CIRCULAR TRIM SAW KIT
Weights Only 6.0 lbs.

- Makita-built motor delivers 3,600 RPM for faster cutting
- Built-in dust blower keeps the line of cut free of debris for more accurate cuts
- Heavy gauge, precision machined base for smooth, accurate cutting and added durability
- Electric brake for maximum productivity
- Built-in L.E.D. light illuminates the work area

Model XSS03 Includes: (2) 18V LXT® Lithium-Ion 3.0Ah Battery (BL1830), 18V Lithium-Ion Rapid Optimum Charger (DC18RC), 5-3/8" 16T C.T. Saw Blade (A-94904), Tool Bag

Model XSS03Z Includes: Tool Only, Battery and Charger not included

Blade Diameter	5-3/8"
Arbor	5/8"
Max. Cutting Capacity:	90° (2"), 45° (1-3/8")
No Load Speed	3,600 RPM
Battery	18V LXT® Lithium-Ion
Overall Length	14-3/8"
Net Weight (with battery)	6 lbs.
Shipping Weight	15.71 lbs.



XVJ02Z

Tool only - battery and charger not included

18v LXT® BRUSHLESS JIG SAW
Up To 45% Faster Cutting³

- Makita-built brushless motor and 3 orbital settings plus straight cutting deliver faster and more accurate cuts in a variety of materials
- Variable 6-speed control dial (800-3,500 SPM) enables user to match the speed to the application
- Efficient BL™ Brushless motor is electronically controlled to optimize battery energy use for up to 50% longer run time per charge
- "Tool-less" blade change system allows for faster blade installation and removal for increased productivity
- The electronically-energy-tooled BL™ Brushless Motor efficiently uses energy to match torque and SPM to the changing demands of the application

Model XVJ02Z Includes: 4-1/8" 9TPI Jig Saw Blade (792529-7-1); Battery and Charger not included

Length of Stroke	1"
Max. Cutting Capacity at 90°:	Aluminum (25/32"), Mild Steel (3/8"), Wood (5-5/16")
Strokes Per Minute (variable speed)	800 - 3,500 SPM
Blade Shank	"T" Tang
Overall Length	10-1/2"
Net Weight (with battery)	5.8 lbs.
Shipping Weight	5.3 lbs.

³ Compared to XVJ03



XVJ03



3.0Ah BATTERY

18v LXT® JIG SAW KIT
Custom Cutting Without a Cord

- Makita-built variable speed motor delivers 0-2,600 strokes per minute for fast and efficient cutting
- 3 orbital settings plus straight cutting for use in a variety of materials
- "Tool-less" blade change system allows for faster blade installation and removal for increased productivity
- Heavy gauge, precision machined base for smooth, accurate cutting and added durability
- Heavy gauge, precision machined base for smooth, accurate cutting and added durability

Model XVJ03 Includes: (2) 18V LXT® Lithium-Ion 3.0Ah Battery (BL1830), 18V Lithium-Ion Rapid Optimum Charger (DC18RC), Jig Saw Blade, T Shank, HCS, 4-1/8" x 9TPI (792729-9-1), Anti-Splintering Insert (415524-7), Tool Bag

Length of Stroke	1"
Max. Cutting Capacity at 90°:	Wood (5-5/16"), Steel (3/8")
Strokes Per Minute (variable speed)	0 - 2,600 SPM
Blade Shank	"T" Tang
Battery	18V LXT® Lithium-Ion
Overall Length	10-1/8"
Net Weight (with battery)	14.7 lbs.
Shipping Weight	14.7 lbs.

NEW Coming Soon



XRJ06Z

18v X2 LXT® (36v)

BRUSHLESS RECIPRO SAW



XRJ05Z

18v LXT® BRUSHLESS RECIPRO SAW



XRJ04Z

18v LXT® RECIPRO SAW



XRJ03Z

Tool only - battery and charger not included

18v LXT® RECIPRO SAW
2,900 SPM and 1-1/8" Stroke for Fast Cutting

- Makita-built variable speed motor delivers 0-2,900 strokes per minute and a 1-1/8" length stroke to provide faster cutting
- "Tool-less" blade change system allows for faster blade installation and removal for increased productivity
- Compact and ergonomic design at only 17-3/4" long
- Weighs only 7.9 lbs. with battery (battery not included) for reduced operator fatigue
- Rubberized soft grip handle provides increased comfort on the job
- Ergonomic shape fits like a glove with even pressure and easy control

Model XRJ03Z Includes: 6" 6TPI Recipro Saw Blade (723054-A-1); Battery and Charger not included

Length of Stroke	1-1/8"
Max. Cutting Capacity:	Pipe (5-1/8"), Wood w/ 12" blade (10")
Strokes Per Minute (variable speed)	0 - 2,900 SPM
Battery	18V LXT® Lithium-Ion
Overall Length	17-3/4"
Net Weight (with battery)	7.9 lbs.
Shipping Weight	8 lbs.



XRJ02



XRJ02Z



3.0Ah BATTERY

18v LXT® RECIPRO SAW KIT
"Tool-less" Blade Change and Shoe Adjustment

- Makita-built variable speed motor delivers 0-2,900 strokes per minute and a 1-1/8" stroke length for faster cutting
- Large 2-finger variable speed trigger for added convenience
- Retractable tool hook secures the tool when not in use
- Soft grip handle provides increased comfort on the job
- Compact and ergonomic design at only 19-5/8" long

Model XRJ02 Includes: (2) 18V LXT® Lithium-Ion 3.0Ah Battery (BL1830), 18V Lithium-Ion Rapid Optimum Charger (DC18RC), 6" 6TPI Recipro Saw Blade (723054-A-1), Tool Case

Model XRJ02Z Includes: Tool Only, Battery and Charger not included

Length of Stroke	1-1/8"
Max. Cutting Capacity:	Pipe (5-1/8"), Wood w/ 12" blade (10")
Strokes Per Minute (variable speed)	0 - 2,900 SPM
Battery	18V LXT® Lithium-Ion
Overall Length	19-5/8"
Net Weight (with battery)	8.2 lbs.
Shipping Weight	18 lbs.



XRJ01



3.0Ah BATTERY

18v LXT® COMPACT RECIPRO SAW KIT
Compact Design for Close Quarter Cutting

- Variable speed (0 - 3,000 SPM) with a 1/2" stroke length for faster and more efficient cutting
- Makita exclusive dual-position on/off switch allows for either paddle or trigger switch operation
- "Tool-less" blade change system allows for faster blade installation and removal for increased productivity
- Compact and ergonomic design at 15-5/8" long
- Weighs only 3.9 lbs. (with battery) for reduced operator fatigue

Model XRJ01 Includes: (2) 18V LXT® Lithium-Ion 3.0Ah Battery (BL1830), 18V Lithium-Ion Rapid Optimum Charger (DC18RC), 4" 18TPI Metal Cutting Recipro Saw Blade (B-20404), 4" 6TPI Wood Cutting Recipro Saw Blade (B-20432), Tool Bag

Model XRJ01Z Includes: Tool Only, Battery and Charger not included

Length of Stroke	1/2"
Max. Cutting Capacity:	Pipe (2"), Wood (2")
Strokes Per Minute (variable speed)	0 - 3,000 SPM
Battery	18V LXT® Lithium-Ion
Overall Length	15-5/8"
Net Weight (with battery)	3.9 lbs.
Shipping Weight	13 lbs.



18v X2 LXT®

XRH05Z Tool only - battery and charger not included

18v X2 LXT® 1" ROTARY HAMMER

18 Volt Solution for Corded Power Demands

- Two 18V LXT® Lithium-Ion batteries deliver the power and run time for corded demands without leaving the 18V LXT® platform
- Makita-built motor delivers 0-1,250 RPM, 0-5,000 BPM and 3.0 Joules of impact energy for fast drilling
- Vibration-absorbing handle engineered for increased operator comfort
- Built-in L.E.D. light illuminates the work area
- 3-Mode operation for "Rotation Only", "Hammering with Rotation" or "Hammering Only"

Model XRH05Z Includes: Tool Only - Side Handle (450990-1), Depth Gauge (324219-0), Tool Bag; Battery and Charger not included

Capacities:	Concrete (1"), Steel (1/2"), Wood (1-1/4")
No Load Speed (variable speed)	0 - 1,250 RPM
Blows Per Minute (variable speed)	0 - 5,000 BPM
Impact Energy (Joules)	3 J
Bit Type	Accepts SDS-PLUS
Battery	2X 18V LXT® Lithium-Ion
Overall Length	13-3/4"
Net Weight (with battery)	9.3 lbs.
Shipping Weight	12.7 lbs.



XRH011X

18v LXT® BRUSHLESS 1" ROTARY HAMMER KIT

- The built-on vacuum attachment captures concrete dust during drilling and is activated by the tool for operator convenience
- Vacuum powered by separate motor to maintain tool drilling performance, and provide a 2-second delay to capture remaining concrete dust
- Efficient HEPA filtration system captures 99.75% of particulates .3 microns and larger

Model XRH011X Includes: (2) 18V LXT® Lithium-Ion 3.0Ah Battery (BL1830), 18V Lithium-Ion Rapid Optimum Charger (DC18RC), Dust Collection Attachment w/ HEPA Filter (DX01), Side Handle (158057-6), Depth Gauge (324219-0), Tool Bag

Model XRH01ZX Includes: HEPA Vacuum (DX01), Tool Bag; battery and charger not included

Capacities:	Concrete (1"), Steel (1/2"), Wood (1-1/16")
No Load Speed (variable speed)	0 - 950 RPM
Blows Per Minute (variable speed)	0 - 4,700 BPM
Impact Energy (Joules)	1.9 J
Bit Type	Accepts SDS-PLUS
Battery	18V LXT® Lithium-Ion
Overall Length	14-5/8"
Net Weight (with battery)	10.2 lbs.
Shipping Weight	19.4 lbs.



XRH01Z

18v LXT® BRUSHLESS 1" ROTARY HAMMER

- Efficient BL™ Brushless motor is electronically controlled to optimize battery energy use for up to 50% longer run time per charge
- The BL™ Brushless Motor eliminates carbon brushes, enabling the BL™ Motor to run cooler and more efficiently for longer life
- Variable speed trigger enables user to match the speed to application for greater versatility
- Multiple Chisel Positions has 40 different positions to align tool more comfortably with the application

Model XRH01Z Includes: Tool Only - Side Handle (158057-6), Depth Gauge (234219-0); Battery and Charger not included

Capacities:	Concrete (1"), Steel (1/2"), Wood (1-1/16")
No Load Speed (variable speed)	0 - 950 RPM
Blows Per Minute (variable speed)	0 - 4,700 BPM
Impact Energy (Joules)	1.9 J
Bit Type	Accepts SDS-PLUS
Battery	18V LXT® Lithium-Ion
Overall Length	12-7/8"
Net Weight (with battery)	7.2 lbs.
Shipping Weight	7.1 lbs.



HRH01

36v 1" ROTARY HAMMER KIT

Corded Speed & Power Without the Cord

- Makita-built motor delivers 0 - 1,200 RPM & 0 - 4,800 BPM
- Ergonomically designed vibration absorbing handle
- 3-mode operation for "Rotation Only", "Hammering with Rotation" or "Hammering Only" for multiple applications
- One-touch sliding chuck for quick bit changes
- Torque Limiting Clutch engineered to prevent gear damage by automatically disengaging gears if the bit binds

Model HRH01 Includes: (2) 36V Lithium-Ion Battery (BL3626), 36V Rapid Optimum Charger (DC36RA), Side Handle (450990-1), Depth Gauge (324219-0), Tool Bag

Capacities:	Concrete (1"), Steel (1/2"), Wood (1-1/4")
No Load Speed (variable speed)	0 - 1,200 RPM
Blows Per Minute (variable speed)	0 - 4,800 BPM
Impact Energy (Joules)	3 J
Bit Type	Accepts SDS-PLUS
Battery	36V LXT® Lithium-Ion
Overall Length	14-1/4"
Net Weight (with battery)	9.9 lbs.
Shipping Weight	26.5 lbs.



XRH04

18v LXT® 7/8" ROTARY HAMMER KIT

- Makita-built variable speed motor delivers 0-1,100 RPM and 0-4,000 BPM
- 3-mode operation for "Rotation Only", "Hammering with Rotation" or "Hammering Only" for multiple applications
- Built-in clutch reduces gear damage by automatically disengaging gears if bit binds
- Faster drilling with synchronized RPM and BPM

Model XRH04 Includes: (2) 18V LXT® Lithium-Ion 3.0Ah Battery (BL1830), 18V Lithium-Ion Rapid Optimum Charger (DC18RC), Side Handle (158057-6), Depth Gauge (324219-0), Tool Bag

Model XRH04Z Includes: Tool Only; Battery and Charger not included

Capacities:	Concrete (7/8"), Steel (1/2"), Wood (1")
No Load Speed (variable speed)	0 - 1,100 RPM
Blows Per Minute (variable speed)	0 - 4,000 BPM
Impact Energy (Joules)	1.9 J
Bit Type	Accepts SDS-PLUS
Battery	18V LXT® Lithium-Ion
Overall Length	16-3/8"
Net Weight (with battery)	7.7 lbs.
Shipping Weight	16.2 lbs.



XRH03

18v LXT® 7/8" ROTARY HAMMER KIT

- Makita-built variable speed motor delivers 0 - 1,100 RPM & 0 - 4,000 BPM
- 3-mode operation for "Rotation Only", "Hammering with Rotation" or "Hammering Only" for multiple applications
- Large 2-finger variable speed trigger for added convenience
- Faster drilling with synchronized RPM and BPM

Model XRH03 Includes: (2) 18V LXT® Lithium-Ion 3.0Ah Battery (BL1830), 18V Lithium-Ion Rapid Optimum Charger (DC18RC), Side Handle (158057-6), Depth Gauge (324219-0), Tool Bag

Model XRH03Z Includes: Tool Only; Battery and Charger not included

Capacities:	Concrete (1/2"), Steel (1"), Wood (7/8")
No Load Speed (variable speed)	0 - 1,100 RPM
Blows Per Minute (variable speed)	0 - 4,000 BPM
Impact Energy (Joules)	1.9 J
Bit Type	Accepts SDS-PLUS
Battery	18V LXT® Lithium-Ion
Overall Length	14-1/8"
Net Weight (with battery)	7.7 lbs.
Shipping Weight	16 lbs.



XRV01

18v LXT® 4" CONCRETE VIBRATOR KIT

- Makita-built motor delivers 13,000 VPM to help increase strength of concrete
- Dual-directional switch to conveniently hold the tool in either horizontal or vertical positions
- Up to 25 minute run-time under load
- Compact and ergonomic design at only 58-1/2" long
- Weighs only 7.7 lbs. with battery for reduced operator fatigue
- Protective cover to help prevent battery contamination

Model XRV01 Includes: (2) 18V LXT® Lithium-Ion 3.0Ah Battery (BL1830), 18V Lithium-Ion Rapid Optimum Charger (DC18RC), Tool Case

Model XRV01Z Includes: Tool Only; Battery and Charger not included

No Load Vibrations/Min.	13,000
Vibrator Diameter	1"
Vibrator Length	8-11/16"
Shaft Length	48"
Battery	18V LXT® Lithium-Ion
Overall Length	58-1/2"
Net Weight (with battery)	7.7 lbs.
Shipping Weight	19.6 lbs.



XRV02

18v LXT® 8" CONCRETE VIBRATOR KIT

- Makita-built motor delivers 12,500 VPM to help increase strength of concrete
- Dual directional switch to conveniently hold the tool in either horizontal or vertical positions
- Up to 25 minute run time under load
- Compact and ergonomic design at only 105-1/2" long
- Protective cover helps prevent battery contamination

Model XRV02 Includes: (2) 18V LXT® Lithium-Ion 3.0Ah Battery (BL1830), 18V Lithium-Ion Rapid Optimum Charger (DC18RC), Tool Case

Model XRV02Z Includes: Tool Only; Battery and Charger not included

No Load Vibrations/Min.	12,500
Vibrator Diameter	1"
Vibrator Length	8-11/16"
Shaft Length	96"
Battery	18V LXT® Lithium-Ion
Overall Length	105-1/2"
Net Weight (with battery)	11.4 lbs.
Shipping Weight	22.18 lbs.

CAPACITY



Miters 0-47° left and 0-57° right; bevels 0-45° left and 0-5° right

TECHNOLOGY



Automatic Speed Change™ adjusts cutting speed and torque during cut for optimum performance

PERFORMANCE

Two 18v LXT® Batteries deliver the power and performance of a corded miter saw

PORTABLE & POWERFUL



NEW XSL02Z

18v X2 LXT® BRUSHLESS 7-1/2" COMPOUND MITER SAW
Powerful BL™ Brushless Motor Delivers 5,700 RPM for Faster Cutting

- Two 18v LXT® Lithium-Ion Batteries deliver the power and performance of a corded miter saw without leaving the 18v LXT® platform
- Automatic Speed Change™ technology adjusts cutting speed and torque during cut for optimum performance
- The BL™ Brushless Motor eliminates carbon brushes, enabling the BL Motor to run cooler and more efficiently for longer life
- Efficient BL™ Brushless motor is electronically controlled to optimize battery energy use for up to 50% longer run time per charge

Model XSL02Z Includes: 7-1/2" 40T C.T. Miter Saw Blade (A-90629); Battery and Charger not included

Blade Diameter	7-1/2"
Arbor	5/8"
Max. Cutting Capacity (Bevel/Miter):	90°/90° (2-1/16" x 11-3/4"), 45°/45° (2-1/16" x 8-3/8")
No Load Speed	5,700 RPM
Battery	2X 18V LXT® Lithium-Ion
Dimensions (LxWxH)	25-3/4" x 17" x 17-1/2"
Net Weight (with battery)	28.9 lbs.
Shipping Weight	38 lbs.

Tool only - battery and charger not included



XSL01

18v LXT® 7-1/2" COMPOUND MITER SAW KIT
Large Cutting Capacity up to 2-1/16" and 11-3/4" Crosscuts at 90°

- Powerful Makita-built motor delivers 2,200 RPM
- Weighs only 27.5 lbs. with battery for reduced operator fatigue
- Four steel rail sliding system increases rigidity to produce superior accurate cuts
- Miters 0-47° left and 0-57° right; bevels 0-45° left and 0-5° right

Model XSL01 Includes: (2) 18V LXT® Lithium-Ion 3.0Ah Battery (BL1830), 18V Lithium-Ion Rapid Optimum Charger (DC18RC), 7-1/2" 40T C.T. Miter Saw Blade (A-90912), (2) Extension Wing (322312-4), Vertical Vise (122571-8), Dust Bag (122852-0), Triangular Rule (762001-3), Socket Wrench (782223-9)

Model XSL01Z Includes: Tool Only; Battery and Charger not included

Blade Diameter	7-1/2"
Arbor	5/8"
Max. Cutting Capacity (Bevel/Miter):	90°/90° (2-1/16" x 11-3/4"), 45°/45° (1" x 11-3/4")
No Load Speed	2,200 RPM
Battery	18V LXT® Lithium-Ion
Dimensions (LxWxH)	25-3/4" x 17" x 17-7/8"
Net Weight (with battery)	27.5 lbs.
Shipping Weight	44 lbs.



XMT03Z



XMT035

3.0Ah BATTERY

18v LXT® MULTI-TOOL KIT
"Tool-less" Clamp System for Fast Accessory Installation

- 18v LXT® Lithium-Ion battery provides up to 20 minutes of continuous run time
- Variable speed control dial (6,000-20,000 OPM) enables user to match the speed to the application
- 3.2° oscillation angle engineered for faster, more aggressive cutting and sanding
- Large on/off slide switch with lock-on button for operator convenience

Model XMT035 Includes: (2) 18V LXT® Lithium-Ion 3.0Ah Battery (BL1830), 18V Lithium-Ion Rapid Optimum Charger (DC18RC), 1-1/4" Plunge Blade (BiM) (A-95255), Multi-Tool Adapter (313249-6), Multi-Tool Adapter (313248-8), Tool Bag

Model XMT03Z Includes: Tool Only; Battery and Charger not included

Oscillations Per Minute	6,000 - 20,000 OPM
Oscillation Angle	3.2°
Battery	18V LXT® Lithium-Ion
Overall Length	13-3/8"
Net Weight (with battery)	4.9 lbs.
Shipping Weight	14.1 lbs.



XOB01Z



XOB01

3.0Ah BATTERY

18v LXT® 5" RANDOM ORBIT SANDER KIT
Corded Performance without the Cord

- Three speed settings (7,000/9,500/11,000 OPM) engineered for fast material removal
- Up to 40 minutes (low speed) and 20 minutes (high speed) of run time on a single charge
- Large 1/8" random orbit action engineered for fast sanding and swirl-free finish
- One-touch electronic speed control switch provides fast, medium and low settings
- Ergonomically designed body and grip for increased operator comfort

Model XOB01 Includes: (2) 18V LXT® Lithium-Ion 3.0Ah Battery (BL1830), 18V Lithium-Ion Rapid Optimum Charger (DC18RC), Tool Bag

Model XOB01Z Includes: Tool Only; Battery and Charger not included

Pad Size (round)	4-7/8"
Abrasive Disc Size	5"
Orbits Per Minute (3 speed)	7,000, 9,500, 11,000 OPM
Orbit Diameter	1/8"
Battery	18V LXT® Lithium-Ion
Overall Length	6-7/8"
Net Weight (with battery)	3.6 lbs.
Shipping Weight	12 lbs.



XPK01Z



XPK01

3.0Ah BATTERY

18v LXT® 3-1/4" PLANER KIT
Planes Up to 3-1/4" Wide and 5/64" Deep in a Single Pass

- 2-blade cutter head with double edge carbide blades for added performance and smooth finish
- High power-to-weight ratio; weighs only 7.4 lbs.
- 14,000 RPM motor engineered for fast stock removal
- Click depth adjustment knob with easy-to-read scale with settings from 0" to 5/64"
- Spring-loaded stand elevates the base to protect the blades and workpiece

Model XPK01 Includes: (2) 18V LXT® Lithium-Ion 3.0Ah Battery (BL1830), 18V Lithium-Ion Rapid Optimum Charger (DC18RC), 3-1/4" Planer Blade Set (D-46246), Blade Gauge (123062-2), Socket Wrench (782209-3), Tool Bag

Model XPK01Z Includes: Tool Only; Battery and Charger not included

Planing Width	3-1/4"
Planing Depth	5/64"
No Load Speed	14,000 RPM
Battery	18V LXT® Lithium-Ion
Overall Length	13-1/8"
Net Weight (with battery)	7.4 lbs.
Shipping Weight	16.3 lbs.



XJP03Z

Tool only - battery and charger not included

18v LXT® PLATE JOINER
Delivers up to 300 Cuts for #0 Biscuits on a Single Charge

- Rack-and-pinion vertical fence system engineered for accurate fence adjustments
- Cast aluminum pivot fence with three positive stops at 0°, 45° and 90°, and easy centering on 3/4" material
- Six depth settings with one-touch stops for #0, #10, and #20 and most common biscuits sizes
- Cordless plate joiner provides portability and performance in the field or in the shop without the cord
- Large and easy-to-operate cam locks for fence adjustments

Model XJP03Z Includes: Tool Only; Battery and Charger not included

Blade Diameter	4"
Cutting Capacity (depth)	3/4"
No Load Speed	6,500 RPM
Battery	18V LXT® Lithium-Ion
Overall Length	13-3/4"
Net Weight (with battery)	6.7 lbs.
Shipping Weight	8.2 lbs.

SPEED

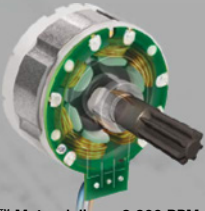

BL™ Motor delivers 3,900 RPM for faster cutting

TECHNOLOGY



AUTOMATIC SPEED CHANGE™
ADJUSTS SPEED & TORQUE FOR OPTIMUM PERFORMANCE

Automatic Speed Change™ adjusts cutting speed and torque during cut for optimum performance

VERSATILITY

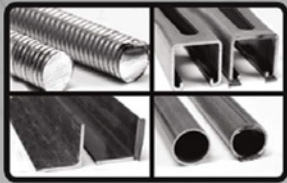

Cuts a wide range of metals including Unistrut®, all thread, channel, conduit, pipe and more

FASTER METAL CUTTING

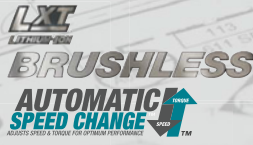

NEW XSC02M

18v LXT® BRUSHLESS 5-7/8" METAL CUTTING SAW KIT
Cuts 2" Conduit in a Single Pass

- Automatic Speed Change™ technology adjusts cutting speed and torque during cut for optimum performance
- Large cutting capacity (2-1/4" at 90°) allows for 2" conduit to be cut in a single pass
- BL™ Motor delivers 3,900 RPM for faster cutting
- The BL™ Brushless Motor eliminates carbon brushes, enabling the BL™ Motor to run cooler and more efficiently for longer life
- Cuts a wide range of metals including Unistrut®, all thread, channel, conduit, pipe, sheet metal, square tubing, steel and more

Model XSC02M Includes: (2) 18V LXT® Lithium-Ion 4.0Ah Battery (BL1840B), 18V Lithium-Ion Rapid Optimum Charger (DC18RC), 5-7/8" 32T C.T. Saw Blade (A-96095), Tool Bag

Model XSC02Z Includes: Tool Only; Battery and Charger not included

Blade Diameter	5-7/8"
Arbor	5/8"
Max. Cutting Depth	2-1/4"
No Load Speed	3,900 RPM
Battery	18V LXT® Lithium-Ion
Overall Length	13-1/8"
Net Weight (with battery)	6.4 lbs.
Shipping Weight	16 lbs.



XSC01MB

18v LXT® 5-3/8" METAL CUTTING SAW KIT
Cuts a Wide Range of Metal Material

- Makita-built motor delivers 3,600 RPM for faster cutting
- Cuts a wide range of metals including Unistrut®, all thread, channel, conduit, pipe, sheet metal, square tubing, steel and more
- Compact and ergonomic design at 13-3/4" long
- Weighs only 5.7 lbs. with battery for reduced operator fatigue
- Rubberized soft grip handle provides increased comfort on the job

Model XSC01MB Includes: 18V LXT® Lithium-Ion 4.0Ah Battery (BL1840B), 18V Lithium-Ion Rapid Optimum Charger (DC18RC), 5-3/8" 30T C.T. Saw Blade (A-95037), Tool Case

Model XSC01Z Includes: Tool Only; Battery and Charger not included

Blade Diameter	5-3/8"
Arbor	5/8"
Max. Cutting Depth	2"
No Load Speed	3,600 RPM
Battery	18V LXT® Lithium-Ion
Overall Length	13-3/4"
Net Weight (with battery)	5.7 lbs.
Shipping Weight	16.5 lbs.



XBP02

18v LXT® PORTABLE BAND SAW KIT
4-3/4" x 4-3/4" Cutting Capacity

- 6-setting variable speed control dial enables user to match the speed to the application
- Built-in L.E.D. protection circuit with over-torque control protects motor
- Protective bumper design for added durability
- Tool hook secures the tool when not in use
- Accepts standard 44-7/8" x 1/2" blades
- Makita-built motor delivers faster cutting with 275-530 ft./min.

Model XBP02 Includes: (2) 18V LXT® Lithium-Ion 3.0Ah Battery (BL1830), 18V Lithium-Ion Rapid Optimum Charger (DC18RC), 44-7/8" 18TPI Band Saw Blade (792556-A), Tool Bag

Model XBP02Z Includes: Tool Only; Battery and Charger not included

Max. Cutting Capacity (rectangular workpiece):	4-3/4" x 4-3/4"
No Load Speed (ft./min., var. speed)	275 - 530 ft./min.
Blade Length	44-7/8"
Battery	18V LXT® Lithium-Ion
Overall Length	20-5/8"
Net Weight (with battery)	14.3 lbs.
Shipping Weight	26 lbs.

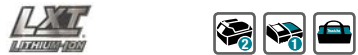

XBP01

18v LXT® COMPACT BAND SAW KIT
2-1/2" x 2-1/2" Cutting Capacity

- Makita-built motor delivers 630 ft./min. blade speed for fast cutting
- 2-1/2" cutting capacity is ideal for cutting conduit, Unistrut®, copper pipe, threaded rod, angle iron and channel
- Includes a blade wheel cover, saw suitable for appropriate one-handed operation: meets ANSI Standard 60745-2-20
- Accepts standard 32-7/8" x 1/2" blades
- Built-in L.E.D. light illuminates the work area

Model XBP01 Includes: (2) 18V LXT® Lithium-Ion 3.0Ah Battery (BL1830), 18V Lithium-Ion Rapid Optimum Charger (DC18RC), Compact Portable Band Saw Blade 32-7/8", 14 TPI (B-40543), Tool Bag

Model XBP01Z Includes: Tool Only; Battery and Charger not included

Max. Cutting Capacity (rectangular workpiece):	2-1/2" x 2-1/2"
No Load Speed (ft./min., var. speed)	630 - ft./min.
Maximum Blade Length	44-7/8"
Battery	18V LXT® Lithium-Ion
Overall Length	18-1/2"
Net Weight (with battery)	7.5 lbs.
Shipping Weight	19 lbs.



XSJ01

18v LXT® 18 GAUGE STRAIGHT SHEAR KIT
Swivel Shear Head Rotates 360°

- Makita-built 4-pole motor delivers 3,000 strokes per minute for faster cutting
- Cuts up to 18 gauge mild steel and 20 gauge stainless steel
- Weighs only 5.3 lbs. with battery for reduced operator fatigue
- Reversible belt-clip attaches to either side of the tool
- Rubberized soft grip handle provides increased comfort on the job

Model XSJ01 Includes: (2) 18V LXT® Lithium-Ion 3.0Ah Battery (BL1830), 18V Lithium-Ion Rapid Optimum Charger (DC18RC), Tool Bag

Model XSJ01Z Includes: Tool Only; Battery and Charger not included

Capacities:	Mild Steel 18 ga. (mm) Stainless 20 ga. (mm)	18 ga. (mm) 16 ga. (mm) 18 ga. (mm)
Strokes Per Minute		3,000 SPM
Battery		18V LXT® Lithium-Ion
Overall Length		13-3/4"
Net Weight (with battery)		5.3 lbs.
Shipping Weight		14 lbs.



XNJ01

18v LXT® 16 GAUGE NIBBLER KIT
Powerful, Versatile and Cordless

- Makita-built motor delivers 1,900 SPM for fast and smooth cutting
- Ideal for cutting roofing sheet metal at thicknesses up to 16 gauge
- Die holder rotates 360° to meet demands of cutting direction
- Convenient chip disposal is below cutting material to minimize damage to cutting surface
- Cutting radius: inner edge 1-3/4"; outer edge 2"

Model XNJ01 Includes: (2) 18V LXT® Lithium-Ion 3.0Ah Battery (BL1830), 18V Lithium-Ion Rapid Optimum Charger (DC18RC), Punch (A-83951), Spanner Wrench (781028-4), Tool Bag

Model XNJ01Z Includes: Tool Only; Battery and Charger not included

Capacities:	Aluminum 12 ga. (mm) Mild Steel 16 ga. (mm) Stainless 18 ga. (mm)	12 ga. (mm) 16 ga. (mm) 18 ga. (mm)
Strokes Per Minute (variable speed)		0 - 1,900 SPM
Cutting Radius: Inner Edge		1-3/4"
Outer Edge		2"
Battery		18V LXT® Lithium-Ion
Overall Length		12-3/8"
Net Weight (with battery)		4.8 lbs.
Shipping Weight		13.3 lbs.

BRUSHLESS WITH ELECTRIC BRAKE



LXT
LITHIUM-ION
BRUSHLESS
AUTOMATIC SPEED CHANGE™
ADJUSTS SPEED & TORQUE FOR OPTIMUM PERFORMANCE

NEW XAG10M

18v LXT® BRUSHLESS 4-1/2" CUT-OFF/ANGLE GRINDER KIT Electric Brake and Large Flush-Mount Paddle Switch

- Electric brake for maximum productivity
- Electronic RPM controller turns the motor off if rotation speed suddenly slows or wheel is forced to stop
- Automatic Speed Change™ technology adjusts speed and torque during operation for optimum performance
- The BL™ Brushless Motor eliminates carbon brushes, enabling the BL™ Motor to run cooler and more efficiently for longer life; delivers 8,500 RPM
- Efficient BL™ Brushless motor is electronically controlled to optimize battery energy use for up to 50% longer run time per charge

Model XAG10M Includes: (2) 18V LXT® Lithium-Ion 4.0Ah Battery (BL1840B), 18V Lithium-Ion Rapid Optimum Charger (DC18RC), 4-1/2" Grinding Wheel (A-95956), 4-1/2" Cut-off Wheel (724115-A), 4-1/2" Wheel Guard (123144-0), 4-1/2" Cut-Off Wheel Guard (122910-2), Tool Case, Side Handle

Model XAG10Z Includes: Tool Only; Battery and Charger not included

Grinding Wheel	4-1/2"
No Load Speed	8,500 RPM
Spindle Thread	5/8" - 11 UNC
Lock-On: No	Lock-Off: Yes
Grinder Switch Type	Body grip/paddle
Battery	18V LXT® Lithium-Ion
Overall Length	14-1/4"
Net Weight (with battery)	5.6 lbs.
Shipping Weight	19.1 lbs.

Z
ZERO TORQUE
REVERSE

XPT
EXTENDED POWER TOOL
TECHNOLOGY
4.0Ah BATTERY



LXT
LITHIUM-ION
BRUSHLESS
AUTOMATIC SPEED CHANGE™
ADJUSTS SPEED & TORQUE FOR OPTIMUM PERFORMANCE

XAG06MB

18v LXT® BRUSHLESS 4-1/2" CUT-OFF/ANGLE GRINDER Large Flush-Mount Paddle Switch for Comfortable Operation

- Automatic Speed Change™ technology adjusts speed and torque during operation for optimum performance
- Electronic RPM controller turns the motor off if rotation speed suddenly slows or wheel is forced to stop
- The BL™ Brushless Motor eliminates carbon brushes, enabling the BL™ Motor to run cooler and more efficiently for longer life; delivers 8,500 RPM

Model XAG06MB Includes: (2) 18V LXT® Lithium-Ion 4.0Ah Battery (BL1840B), 18V Lithium-Ion Rapid Optimum Charger (DC18RC), 4-1/2" Grinding Wheel (A-95956), 4-1/2" Cut-off Wheel (724115-A), 4-1/2" Wheel Guard (123144-0), 4-1/2" Cut-Off Wheel Guard (122910-2), Side Handle, Tool Case

Model XAG06Z Includes: Tool Only; Battery and Charger not included

Grinding Wheel	4-1/2"
No Load Speed	8,500 RPM
Spindle Thread	5/8" - 11 UNC
Lock-On: No	Lock-Off: Yes
Grinder Switch Type	Body grip/paddle
Battery	18V LXT® Lithium-Ion
Overall Length	14-1/4"
Net Weight (with battery)	5.6 lbs.
Shipping Weight	19.1 lbs.



LXT
LITHIUM-ION
BRUSHLESS
AUTOMATIC SPEED CHANGE™
ADJUSTS SPEED & TORQUE FOR OPTIMUM PERFORMANCE

XAG03MB

18v LXT® BRUSHLESS 4-1/2" CUT-OFF/ANGLE GRINDER KIT Slide Switch For User Convenience

- BL™ Brushless motor delivers 8,500 RPM
- Automatic Speed Change™ technology adjusts speed and torque during operation for optimum performance
- The BL™ Brushless Motor eliminates carbon brushes, enabling the BL™ Motor to run cooler and more efficiently for longer life

Model XAG03MB Includes: (2) 18V LXT® Lithium-Ion 4.0Ah Battery (BL1840B), 18V Lithium-Ion Rapid Optimum Charger (DC18RC), 4-1/2" Grinding Wheel (A-95956), 4-1/2" Cut-off Wheel (724115-A), 4-1/2" Wheel Guard (123144-0), 4-1/2" Cut-Off Wheel Guard (122910-2), Side Handle, Tool Case

Model XAG03Z Includes: Tool Only; Battery and Charger not included

Grinding Wheel	4-1/2"
No Load Speed	8,500 RPM
Spindle Thread	5/8" - 11 UNC
Lock-On: Yes	Lock-Off: No
Grinder Switch Type	Body grip/slide
Battery	18V LXT® Lithium-Ion
Overall Length	14-1/4"
Net Weight (with battery)	5.5 lbs.
Shipping Weight	19 lbs.



Z
ZERO TORQUE
REVERSE

LXT
LITHIUM-ION

XAG01

18v LXT® 4-1/2" CUT-OFF/ANGLE GRINDER KIT Compact Barrel Grip for Easy Handling

- Makita-built motor delivers 10,000 RPM for faster grinding
- Built-in L.E.D. protection circuit with over-torque control protects motor
- Compact and ergonomic design at only 12-1/2" long
- Weighs only 5.0 lbs. with battery for reduced operator fatigue
- Rubberized soft grip provides increased comfort on the job

Model XAG01 Includes: (2) 18V LXT® Lithium-Ion 3.0Ah Battery (BL1830), 18V Lithium-Ion Rapid Optimum Charger (DC18RC), 4-1/2" Wheel Guard (125273-5), 4-1/2" Cut-Off Wheel Guard (135103-2), 4-1/2" Grinding Wheel (A-95956), 4-1/2" Cut-off Wheel (724115-A), Tool Case

Model XAG01Z Includes: Tool Only; Battery and Charger not included

Grinding Wheel	4-1/2"
Wire Cup Brush	3-1/2"
No Load Speed	10,000 RPM
Spindle Thread	5/8" - 11 UNC
Battery	18V LXT® Lithium-Ion
Overall Length	12-1/2"
Net Weight (with battery)	5 lbs.
Shipping Weight	16 lbs.



Z
ZERO TORQUE
REVERSE

LXT
LITHIUM-ION

XDG01

18v LXT® 1/4" DIE GRINDER KIT Delivers 25,000 RPM for Faster Grinding

- Compact barrel grip design and weighs only 4.4 lbs. for easy handling
- Slide switch with lock-on for operator convenience
- Vent slots designed to direct exhaust air away from the user
- L.E.D. light flashes red when it is time to recharge the battery
- Built-in L.E.D. protection circuit with over-torque control protects the motor

Model XDG01 Includes: (2) 18V LXT® Lithium-Ion 3.0Ah Battery (BL1830), 18V Lithium-Ion Rapid Optimum Charger (DC18RC), 1/4" Collet (763625-8), (2) Spanner Wrench (781039-9), Tool Bag

Model XDG01Z Includes: Tool Only; Battery and Charger not included

Max. Wheel Diameter	1-1/2"
Collet	1/4"
No Load Speed	25,000 RPM
Lock-On: Yes	Lock-Off: No
Battery	18V LXT® Lithium-Ion
Overall Length	15-3/4"
Net Weight (with battery)	4.4 lbs.
Shipping Weight	14 lbs.

CUTS UP TO 3/4" GRADE 60 #6 REBAR



LXT
LITHIUM-ION

XCS01Z

18v LXT® REBAR CUTTER Up To 75 Cuts Of #6 3/4" Rebar with A 3.0Ah LXT® Battery

- Cutting capacity range of 1/8" - 3/4"; cuts up to 60 grade #6 rebar
- Long lasting cutting blades provide up to 4,000 cuts before needing to be replaced
- Cutting head rotates 360° for different cutting positions
- Adjustable stopper holds the rebar at 90° to the cutting blade and assists in smooth cutting
- Ergonomic pistol grip handle with rubberized soft grip provides increased comfort on the job

Model XCS01Z Includes: Tool Only; Battery and Charger not included

Cutting Capacity (thickness)	3/4"
Variable Speed	No
Battery	18V LXT® Lithium-Ion
Overall Length	16-1/5"
Net Weight (with battery)	24.3 lbs.
Shipping Weight	35.2 lbs.



XSF03Z



XRF02Z



XRF01Z



XSF03MB

18v LXT® BRUSHLESS DRYWALL SCREWDRIVER KIT

Drives 1,860 Screws with Push Drive™ Technology using 4.0Ah BL1840B Battery¹

- BL™ Motor delivers 0-4,000 RPM to handle a variety of drywall and framing applications
- Push Drive™ Technology – in lock-on mode the motor starts only when the fastener is engaged for a quieter work environment and to save battery power
- Ergonomically designed rubberized pistol grip with large 2-finger trigger for increased comfort
- Adjustable nose piece delivers consistent screw depth

Model XSF03MB Includes: (2) 18V LXT® Lithium-Ion 4.0Ah Battery (BL1840B), 18V Lithium-Ion Rapid Optimum Charger (DC18RC), 3" Magnetic Bit Holder (784812-6), Tool Case

Model XSF03Z Includes: Tool Only; Battery and Charger not included

Bit Type	1/4" Hex
No Load Speed (variable speed)	0 - 4,000 RPM
Battery	18V LXT® Lithium-Ion
Overall Length	9-7/8"
Net Weight (with battery)	3.8 lbs.
Shipping Weight	13 lbs.

¹ 1-1/4" screw attaching 1/2" drywall to a 20 ga. steel stud



XSF01Z

18v LXT® DRYWALL SCREWDRIVER

A Cordless Solution for Drywall and Framing Applications

- Makita-built motor delivers 0-4,000 RPM to handle drywall and framing applications
- Ergonomically designed rubberized pistol grip for increased comfort
- Adjustable nose piece delivers consistent screw depth
- Compact and ergonomic design at only 11-1/8" long
- Weighs only 3.8 lbs. with battery (battery not included) for reduced operator fatigue
- Built-in L.E.D. light illuminates the work area

Model XSF01Z Includes: Tool Only; Battery and Charger not included

Bit Type	1/4" Hex
No Load Speed (variable speed)	0 - 4,000 RPM
Battery	18V LXT® Lithium-Ion
Overall Length	11-1/8"
Net Weight (with battery)	3.8 lbs.
Shipping Weight	3 lbs.



XRF02

18v LXT® AUTOFEED SCREWDRIVER KIT

Ideal for Hanging Drywall

- Makita-built 4-pole motor delivers superior fastening speed with 4,000 RPM
- High collated screw capacity range: 1" to 2-1/8"
- Screw guide prevents screw strip tangling and can fold against the autofeed housing for easy storing
- Rugged aluminum dust-proof autofeed housing provides smooth sliding action

Model XRF02 Includes: (2) 18V LXT® Lithium-Ion 3.0Ah Battery (BL1830), 18V Lithium-Ion Rapid Optimum Charger (DC18RC), #2 Phillips Power Bit, 2/pk (B-10481), Square Power Bit, 1/pk (784645-9), Tool Bag

Model XRF02Z Includes: Tool Only; Battery and Charger not included

Bit Type	1/4" Hex
Collated Screw Capacity	1" - 2-3/16"
No Load Speed	4,000 RPM
Battery	18V LXT® Lithium-Ion
Overall Length	16-3/4"
Net Weight (with battery)	5.1 lbs.
Shipping Weight	13.4 lbs.



XRF01

18v LXT® AUTOFEED SCREWDRIVER KIT

Ideal for Decking and Subfloors

- Makita-built 4-pole motor delivers superior fastening speed with 4,000 RPM for decking and sub-floor applications
- High collated screw capacity range: 1-3/4" to 2-15/16"
- Screw guide prevents screw strip tangling and can fold against the autofeed housing for easy storing
- Rugged aluminum dust-proof autofeed housing provides smooth sliding action

Model XRF01 Includes: (2) 18V LXT® Lithium-Ion 3.0Ah Battery (BL1830), 18V Lithium-Ion Rapid Optimum Charger (DC18RC), #2 Phillips Power Bit, 1/pk (B-10475-1), Tool Bag

Model XRF01Z Includes: Tool Only; Battery and Charger not included

Bit Type	1/4" Hex
Collated Screw Capacity	1-3/4" - 2-15/16"
No Load Speed	4,000 RPM
Battery	18V LXT® Lithium-Ion
Overall Length	18-1/4"
Net Weight (with battery)	5.2 lbs.
Shipping Weight	13.8 lbs.



XOC01Z



XOC01MB

18v LXT® CUT-OUT TOOL KIT

Slim Body Design (2-1/4") for Comfort and Control

- Makita-built motor delivers 30,000 RPM for faster cutting
- Slide switch with lock-on for operator convenience
- On board bit change capabilities eliminates need for wrench
- Quick and easy "tool-less" depth adjustment
- Slim body design (2-1/4" diameter) for comfort and precision
- Large and conveniently located shaft lock button for fast bit changes

Model XOC01MB Includes: (2) 18V LXT® Lithium-Ion 4.0Ah Battery (BL1840B), 18V Lithium-Ion Rapid Optimum Charger (DC18RC), 1/8" Cut-Out Bit (193446-8), Spanner Wrench (781008-0), Tool Bag

Model XOC01Z Includes: Tool Only; Battery and Charger not included

Collet Capacity	1/8", 1/4"
No Load Speed	30,000 RPM
Battery	18V LXT® Lithium-Ion
Overall Length	12-3/8"
Net Weight (with battery)	3.7 lbs.
Shipping Weight	11 lbs.



XTS01Z



XTS01

18v LXT® 3/8" CROWN STAPLER KIT

Contact Actuation for Production Environments

- Makita-built motor delivers power to fasten a wide range of 3/8" crown staples (lengths 1/4", 3/8", 1/2", 5/8", 3/4" & 7/8"); also utilizes Arrow® T50
- Spring-loaded driving mechanism allows for a more compact tool with less weight
- Contact actuation is well-suited for production environment
- Rugged machined aluminum magazine ensures smooth loading and feeding of staples

Model XTS01 Includes: (2) 18V LXT® Lithium-Ion 3.0Ah Battery (BL1830), 18V Lithium-Ion Rapid Optimum Charger (DC18RC), Tool Bag

Model XTS01Z Includes: Tool Only; Battery and Charger not included

Staple Width	3/8"
Leg Length	1/4" to 7/8"
Crown	3/8"
Staple Magazine Capacity	98 staples
Battery	18V LXT® Lithium-Ion
Overall Length	9-7/8"
Net Weight (with battery)	5.3 lbs.
Shipping Weight	15.8 lbs.



XTP01Z

18v LXT® PIN NAILER, 23 GA.

Drives up to 3,000 Nails using 3.0Ah 18v LXT® Battery BL1830

- Drives 4 different lengths of 23 gauge pin nails (11/16", 1", 1-3/16" and 1-3/8"); magazine capacity up to 130 nails
- Anti dry-fire mechanism stops the tool when three nails remain in the magazine
- Compact and ergonomic design at only 9-3/4" long
- Weighs only 4.6 lbs. with battery (battery not included) for reduced operator fatigue
- Built-in L.E.D. lights illuminate the work area
- Rubberized soft grip handle provides increased comfort on the job

Model XTP01Z Includes: Tool Only; Battery and Charger not included

Staple Width	1/32"
Leg Length	11/16" to 1-3/8"
Staple Magazine Capacity	130 staples
Battery	18V LXT® Lithium-Ion
Overall Length	9-3/4"
Net Weight (with battery)	4.6 lbs.
Shipping Weight	4.7 lbs.



XNB01Z

18v LXT® 2" BRAD NAILER, 18 GA.

Drives 1000 Nails using 3.0Ah LXT® Battery BL1830²

- Drives a range of 18 gauge brad nails from 5/8" to 2"; magazine capacity up to 110 nails
- 2-mode selector switch for sequential or contact nailing operation
- Easy to use "tool-less" depth adjustment dial for a wide variety of finish applications
- Anti-dry drive mechanism engineered to prevent driving blanks and damage to work surface
- Battery gauge indicates battery charge level
- Built-in L.E.D. light illuminates the work area

Model XNB01Z Includes: Tool Only; Battery and Charger not included

Nail Size	5/8" to 2" (18 ga.)
Magazine Capacity	110
Battery	18V LXT® Lithium-Ion
Overall Length	11-5/8"
Net Weight (with battery)	7.7 lbs.
Shipping Weight	8 lbs.

² Attaching plywood to Douglas fir with 5/8" to 2" nail



Z
SAME SIZE
XGC01Z



XGC011

3.0Ah BATTERY

18v LXT® 10 OZ. CAULK/ADHESIVE GUN KIT
Delivers an Industry-Leading 1,100 lbs. of Dispensing Force

- Makita-built motor delivers 1,100 lbs. of dispensing force to dispense the highest viscosity adhesives and sealants
- 5-speed dial optimizes flow rate from 0-66 IPM
- Variable speed trigger allows user match speed to the application
- 360° rotatable cartridge holder fits 10 oz. and 300 ml cartridges

Model XGC011 Includes: 18V LXT® Lithium-Ion 3.0Ah Battery (BL1830), 18V Lithium-Ion Rapid Optimum Charger (DC18RC), Tool Bag

Model XGC01Z Includes: Tool Only; Battery and Charger not included

Capacity (caulk or sealants)	10 oz.
Dispense Force	1,100 lbs.
Inches Per Minute (variable speed)	0 - 66 IPM
Speed Settings	5
Battery	18V LXT® Lithium-Ion
Overall Length	15-7/8"
Net Weight (with battery)	5.1 lbs.
Shipping Weight	13.1 lbs.



Z
SAME SIZE
XGC01ZB



XGC011B

3.0Ah BATTERY

18v LXT® 20 OZ. CAULK GUN KIT
Delivers Up To 2.5X More Dispensing Speed³

- Makita-built motor delivers 1,100 lbs. of dispensing force to dispense the highest viscosity adhesives and sealants
- 5-speed dial optimizes flow rate from 0-66 IPM
- Variable speed trigger allows user match speed to the application
- 360° rotatable cartridge holder fits 20 oz. cartridges, sausage packs and bulk caulk and adhesives
- Includes 3 pistons for use with cartridges, sausage packs and bulk materials

Model XGC011B Includes: 18V LXT® Lithium-Ion 3.0Ah Battery (BL1830), 18V Lithium-Ion Rapid Optimum Charger (DC18RC)

Model XGC01ZB Includes: Tool Only; Battery and Charger not included

Capacity (caulk or sealants)	20 oz.
Dispense Force	1,100 lbs.
Inches Per Minute (variable speed)	0 - 66 IPM
Speed Settings	5
Battery	18V LXT® Lithium-Ion
Overall Length	21-1/4"
Net Weight (with battery)	6 lbs.
Shipping Weight	12.01 lbs.

³ Compared to leading competitor

POWERFUL DISPENSING FORCE



Z
SAME SIZE
XGC01ZC



VERSATILITY
5 speed dial optimizes flow rate from 0 - 66 IPM



4.0Ah BATTERY

NEW XGC01M1C

18v LXT® 29 OZ. CAULK AND ADHESIVE GUN KIT
Delivers an Industry-Leading 1,100 lbs. of Dispensing Force

- 5-speed dial optimizes flow rate from 0-66 IPM
- Variable speed trigger allows user to match speed to the application
- 360° rotatable cartridge holder fits 29 oz. cartridges
- Drip-reduction feature automatically relieves pressure on the material when trigger is released to prevent unintentional dispensing
- Overload indicator light notifies the operator when tool is nearly overloaded to minimize breakage of the sealant cartridge

Model XGC01M1C Includes: 18V LXT® Lithium-Ion 4.0Ah Battery (BL1840B), 18V Lithium-Ion Rapid Optimum Charger (DC18RC), Holder C (455951-6), Holder Joint C (143223-8), Piston D (143221-2), Rod (143220-4), Tool Bag

Model XGC01ZC Includes: Tool Only; Battery and Charger not included

Capacity (caulk or sealants)	29 oz.
Dispense Force	1,100 lbs.
Inches Per Minute (variable speed)	0 - 66 IPM
Speed Settings	5
Battery	18V LXT® Lithium-Ion
Overall Length	18-7/8"
Net Weight (with battery)	5.9 lbs.
Shipping Weight	14 lbs.

18V LXT® FANS & BLOWER

Caulking Gun Accessories



196351-8

10 oz. Cartridge Holder Set
Holds 10 oz. cartridge style caulks and adhesives



196352-6

20 oz. Barrel Holder Set
Holds 20 oz. cartridge style, sausage style and bulk caulks and adhesives



197195-9

29 oz. Cartridge Holder Set
Holds 29 oz. cartridge style caulks and adhesives



DCF300Z

Tool only - battery and charger not included

18v LXT® 13" JOB SITE FAN
Up to 5.7 Hours of Continuous Run-Time on a Single Charge⁴

- Durable design engineered to withstand a job site environment
- Frame structure engineered to reduce wind noise
- Three settings (high/medium/low) and oscillation selector for optimal air velocity and control
- 3-stage automatic timer with 1, 2, and 4 hour power-off selection
- Removable front guard for convenient clean up
- Tilt up/down design make it convenient to redirect air flow

Model DCF300Z Includes: AC Adapter; Battery and Charger not included

Voltage	18V
AC Adaptor	Yes
Run Time (max, in hours)	5.7
Battery	18V LXT® Lithium-Ion
Dimensions (LxWxH)	12-1/2" x 18-9/10" x 23-7/10"
Net Weight (with battery)	10.4 lbs.
Shipping Weight	12.6 lbs.

⁴ In low speed using a BL1850 battery



BCF201Z

Tool only - battery and charger not included

18v LXT® JOB SITE FAN
Up to 5.5 Hours of Continuous Run Time on a Single Charge

- Durable design engineered to withstand a job site environment
- Protective bumpers for increased durability
- Two settings (high 1,700 RPM, low 1,200 RPM) for optimal air velocity control
- 3-stage automatic timer with 1, 2, and 4 hour power-off selection
- Large carrying handle for easy handling
- 45° adjustable platform allows a full range of fan positions

Model BCF201Z Includes: AC Adapter; Battery and Charger not included

Voltage	14.4-18V
AC Adaptor	Yes
Speed (2 speed)	0 - 1,700, 0 - 1,200 RPM
Run Time (max, in hours)	5.5
Battery	18V LXT® Lithium-Ion
Dimensions (LxWxH)	5" x 13-3/5" x 21-1/10"
Net Weight (with battery)	5.7 lbs.
Shipping Weight	7.1 lbs.



DUB182



3.0Ah BATTERY

18v LXT® BLOWER KIT
179 MPH for Fast Clean-Ups

- Variable speed (0-18,000 RPM) for optimum speed control
- Up to 12 minutes of continuous operation at high speed with a 3.0Ah LXT® battery
- Compact and ergonomic design at only 20-3/4" long
- Weighs only 3.9 lbs. with battery for reduced operator fatigue
- Rubberized soft grip handle for increased operator comfort
- Makita-built variable 3-speed motor produces a maximum air velocity of 179 MPH

Model DUB182 Includes: 18V LXT® Lithium-Ion 3.0Ah Battery (BL1830), 18V Lithium-Ion Rapid Optimum Charger (DC18RC), Rubber Blower Nozzle (132025-7), Tool Bag

Model DUB182Z Includes: Tool Only; Battery and Charger not included

Air Volume	91 CFM
Max. Air Velocity	179 MPH
No Load Speed (variable speed)	0 - 18,000 RPM
Battery	18V LXT® Lithium-Ion
Net Weight (with battery)	3.7 lbs.
Shipping Weight	11 lbs.

PORTABLE & VERSATILE



18v 18v 36v

XBU02Z

Tool only - battery and charger not included

18v X2 LXT® (36v) BRUSHLESS BLOWER

Makita-Built BL™ Brushless Motor Produces A Maximum 473 CFM

- Delivers up to 29 minutes of run time at 15,800 RPM using two 18V LXT® 5.0Ah batteries
- Makita-built motor produces a maximum air velocity of 120 MPH
- 6-stage air velocity/volume selection dial with variable speed control trigger
- Two 18V LXT® Lithium-Ion batteries deliver the power and run time for gas powered demands without leaving the 18V LXT® platform
- Zero emissions and reduced maintenance; no need for gas or oil

Model XBU02Z Includes: Tool Only - Long Nozzle (455915-0); Battery and Charger not included

Max Air Volume	473 CFM
Max. Air Velocity	120 MPH
No Load Speed (variable speed)	11,400 - 21,500 RPM
Battery	2X 18V LXT® Lithium-Ion
Sound Pressure	96 dB(A)
Overall Length	38-3/4"
Net Weight (with battery)	9.9 lbs.
Shipping Weight	8.4 lbs.



18v 18v 36v

XBU01Z

Tool only - battery and charger not included

18v X2 LXT® (36v) BLOWER

Makita-built Motor Produces a Maximum Air Volume of 155 CFM

- Delivers up to 28 minutes of run time using two 5.0Ah 18V LXT® batteries on highest speed setting
- Makita-built motor produces a maximum air velocity of 208 MPH
- 2-speed (Low: 10,000 RPM, High: 17,000 RPM) design to match the speed to application
- Two 18V LXT® Lithium-Ion batteries deliver the power and run time for corded demands without leaving the 18V LXT® platform
- Compact and ergonomic design at only 36-1/4" long

Model XBU01Z Includes: Tool Only - Long Blower Nozzle (452123-4); Battery and Charger not included

Max Air Volume	155 CFM
Max. Air Velocity	208 MPH
No Load Speed (2 spd)	10,000/17,000 RPM
Battery	2X 18V LXT® Lithium-Ion
Sound Pressure	86 dB(A)
Overall Length	36-1/4"
Net Weight (with battery)	8 lbs.
Shipping Weight	6 lbs.



36v

UB360DWB

2.2Ah BATTERY

36v BLOWER KIT

Delivers up to 14 Minutes of Run Time with 36v Battery Under No Load on Highest Setting

- Makita-built motor produces a maximum air velocity of 208 MPH with up to 30 min. of continuous run time
- 2-speed (Low: 10,000 RPM, High: 17,000 RPM) design to match the speed to application
- Lower noise level at only 86 dB(A) for improved user comfort, 30% quieter than gas
- Zero emissions, and reduced maintenance for increased ease of use

Model UB360DWB Includes: 36V Lithium-Ion Battery (BL3622A), 36V Charger (DC36WA), Long Blower Nozzle (452123-4)

Max Air Volume	155 CFM
Max. Air Velocity	208 MPH
No Load Speed (2 spd)	10,000/17,000 RPM
Battery	36V LXT® Lithium-Ion
Sound Pressure	86 dB(A)
Overall Length	36-1/4"
Net Weight (with battery)	6.8 lbs.
Shipping Weight	11 lbs.



XRU04Z

Tool only - battery and charger not included

18v LXT® BRUSHLESS STRING TRIMMER

Up to 60 Minutes of Run Time with 3.0Ah Battery under No Load on the Lowest Setting

- BL™ Brushless motor delivers up to 6,000 RPM for faster cutting
- Adjustable speed dial (0-3,500 to 0-6,000 RPM) allows the operator to match speed to application
- Compact size is ideal for trimming and precise edging
- Zero emissions and reduced maintenance; no need for gas or oil

Model XRU04Z Includes: Tool Only - Trimmer Head (123235-7), Shoulder Strap (125516-5), Goggles (195246-2), Hex Wrench (783217-7), Hex Wrench (783202-0), Accessory Bag (831304-7); Battery and Charger not included

Cutting Capacity (diameter)	11-3/4"
No Load Speed (2 spd)	3,500/6,000 RPM
Battery	18V LXT® Lithium-Ion
Overall Length	72-1/2"
Net Weight (with battery)	8.6 lbs.
Shipping Weight	18.7 lbs.



XRU02Z

Tool only - battery and charger not included

18v LXT® STRING TRIMMER

Up to 45 Minutes of Run Time with 3.0Ah Battery Under No Load

- Makita-built motor delivers 7,800 RPM for faster cutting
- Telescoping shaft (48-1/2" to 56-1/2") for optimum cutting position
- Adjustable 5-position pivoting head for cutting angle adjustment when trimming in tight spaces
- 180° rotating head allows the trimmer to convert to edger; 10-1/4" cutting width
- Compact size is ideal for trimming and precise edging

Model XRU02Z Includes: Tool Only - Trimmer Head (196146-9), Nylon Cord (196148-5); Battery and Charger not included

Cutting Capacity (diameter)	10-1/4"
No Load Speed	7,800 RPM
Battery	18V LXT® Lithium-Ion
Overall Length	10-1/4"
Net Weight (with battery)	6.9 lbs.
Shipping Weight	8.8 lbs.



XMU02Z

Tool only - battery and charger not included

18v LXT® GRASS SHEAR

Up to 125 Minutes of Run Time with 3.0Ah battery Under No Load

- Makita-built motor delivers 1,250 SPM for efficient cutting
- Toboggan-style base frame enables user to quickly adjust height to match the application
- Dual blade action cuts with a shearing effect for improved results
- Non-electrolyzed nickel plated blades engineered to resist staining and rusting
- Weighs only 3.6 lbs. with battery (battery not included) for reduced user fatigue

Model XMU02Z Includes: Tool Only - Blade Cover (452055-5); Battery and Charger not included

Cutting Capacity (width)	6-5/16"
Depth Adjustment Range	3/8", 13/16", 1-3/16"
No Load Speed	1,250 RPM
Battery	18V LXT® Lithium-Ion
Overall Length	13-7/8"
Net Weight (with battery)	3.6 lbs.
Shipping Weight	3.45 lbs.



XHU02Z

Tool only - battery and charger not included

18v LXT® HEDGE TRIMMER

Up to 75 Minutes of Run Time with 3.0Ah Battery on Lowest Setting

- Makita-built motor delivers 1,350 SPM for increased cutting speed
- 22" blade provides increased cutting capacity
- Anti-vibration design (five cushions within the motor housing) helps minimize vibration
- Battery capacity warning system; motor stops and light goes on indicating battery needs recharging (battery and charger sold separately)
- Lower noise level at only 87 dB(A) for operator comfort
- Compact and ergonomic design at only 38" long

Model XHU02Z Includes: Tool Only - Blade Cover (450490-1); Battery and Charger not included

Blade Length	22"
Strokes Per Minute	1,350 SPM
Battery	18V LXT® Lithium-Ion
Overall Length	38"
Net Weight (with battery)	7.4 lbs.
Shipping Weight	9.1 lbs.



HCU02C1

2.2
BATTERY

36v CHAIN SAW KIT
Zero Emissions and up to 40% Quieter Than Gas

- Makita-built motor delivers 1,650 FPM for increased cutting speed
- Lower noise level at only 89 dB(A) for improved user comfort
- "Tool-less" chain adjustments for convenient operation and maintenance
- Front hand guard engineered to actuate chain brake when engaged
- 12" guide bar for increased capacity

Model HCU02C1 Includes: 36V Lithium-Ion Battery (BL3622A), 36V Charger (DC36WA), 12" Guide Bar (165245-8), 12" Saw Chain (531-290-046)

Guide Bar Length	12"
Chain Speed	1,650 FPM
Chain Pitch	3/8"
Chain Gauge	.043"
Battery	36V LXT® Lithium-Ion
Overall Length	24-5/8"
Net Weight (with battery)	10.1 lbs.
Shipping Weight	14 lbs.



18v | 18v | 36v

XCU02Z

Tool only - battery and charger not included

18v X2 LXT® (36v) CHAIN SAW
Powered by Two 18v LXT® Lithium-Ion Batteries

- Makita-built motor delivers 1,650 FPM chain speed for fast cutting
- Two 18V LXT® Lithium-Ion batteries deliver power and performance without leaving the 18V LXT® platform (batteries not included)
- 12" guide bar for increased capacity
- "Tool-less" chain adjustments for convenient operation and maintenance
- Front hand guard actuates chain brake when engaged

Model XCU02Z Includes: Tool Only - 12" Guide Bar (165245-8), 12" Saw Chain (531-290-046), Blade Cover; Battery and Charger not included

Guide Bar Length	12"
Chain Speed	1,650 FPM
Chain Pitch	3/8"
Chain Gauge	.043"
Battery	2X 18V LXT® Lithium-Ion
Overall Length	24-5/8"
Net Weight (with battery)	11.2 lbs.
Shipping Weight	8.8 lbs.



XCU01Z

Tool only - battery and charger not included

18v LXT® 4-1/2" CHAIN SAW
The Perfect Chain Saw for Limbing, Powered by 18v LXT®

- Makita-built motor delivers 980 FPM for increased cutting speed
- 4-1/2" guide bar is ideal for limbing
- "Tool-less" chain adjustments for convenient operation and maintenance
- Zero emissions and reduced maintenance
- Compact and ergonomic design at only 16-5/8" long
- Weighs only 5.4 lbs. with battery (battery not included) for reduced operator fatigue

Model XCU01Z Includes: Tool Only - 4-1/2" Saw Chain, 1/4"-.050", LXC0U1, UC120DWD (791284-8), 4-1/2" Guide Bar, LXC0U1, UC120DWD (158476-6); Battery and Charger not included

Guide Bar Length	4-1/2"
Chain Speed	980 FPM
Chain Pitch	1/4"
Chain Gauge	.050"
Battery	18V LXT® Lithium-Ion
Overall Length	16-5/8"
Net Weight (with battery)	5.4 lbs.
Shipping Weight	7.1 lbs.



HHU01C1

2.2
BATTERY

36v HEDGE TRIMMER KIT
36v Lithium-Ion Battery Delivers the Cutting Performance of a Corded Trimmer

- Makita-built motor delivers 1,800 SPM for fast cutting
- 25-1/2" blade provides increased cutting capacity
- 6 speed dial (0 - 1,800 SPM) allows the user to match the speed to the application
- Lower noise level at only 86.5 dB(A); up to 30% quieter than gas
- 5-position rotating rear handle for increased comfort during vertical and angle trimming

Model HHU01C1 Includes: Tool Only - 36V Charger (DC36WA), 36V Lithium-Ion Battery (BL3622A); Battery and Charger not included

Blade Length	25-1/2"
Strokes Per Minute	1,800 SPM
Battery	36V LXT® Lithium-Ion
Overall Length	48-3/4"
Net Weight (with battery)	11.7 lbs.
Shipping Weight	19.8 lbs.



18v | 18v | 36v

XHU04Z

Tool only - battery and charger not included

18v X2 LXT® HEDGE TRIMMER
Two 18v LXT® Lithium-Ion Batteries Deliver the Cutting Performance of a Corded Trimmer

- Makita-built motor delivers 1,800 SPM for fast cutting
- 25-1/2" blade provides increased cutting capacity
- 6 speed dial (0 - 1,800 SPM) allows the user to match the speed to the application
- Lower noise level at only 86.5 dB(A); up to 30% quieter than gas
- Weighs only 13.3 lbs. with (2) 18V batteries (batteries not included) for reduced operator fatigue

Model XHU04Z Includes: Tool Only - Blade Cover; Battery and Charger not included

Blade Length	25-1/2"
Strokes Per Minute	1,800 SPM
Battery	2X 18V LXT® Lithium-Ion
Overall Length	48-3/4"
Net Weight (with battery)	13.3 lbs.
Shipping Weight	13.7 lbs.



18v | 18v | 36v

XRU07Z

Tool only - battery and charger not included

18v X2 LXT® (36v) BRUSHLESS STRING TRIMMER
Zero Emissions and Reduced Maintenance; No Need for Gas or Oil

- Makita-built Outer Rotor BL™ Brushless Motor direct-drive system provides high power and increased torque
- Constant Speed Control minimizes reduction in rotation speed under load
- 2-speed options (Low: 0-5,000 RPM, High: 0-6,500 RPM) allows the operator to match speed to application
- Delivers up to 60 minutes of run time under load on the low speed setting using two 18V LXT® 5.0Ah BL1850 batteries*

Model XRU07Z Includes: Tool Only - Bump & Feed Trimmer Head, XRU07 Trimmer Head (197297-1), Goggles (195246-2), Hex Wrench (783217-7), Hex Wrench (783202-0), Accessory Bag (831304-7); Battery and Charger not included

Cutting Capacity (diameter)	13-3/4"
No Load Speed (2 spd)	5,000/6,500 RPM
Battery	2X 18V LXT® Lithium-Ion
Overall Length	69"
Net Weight (with battery)	9.9 lbs.
Shipping Weight	12.1 lbs.

NO LIMITS
POWER & SPEED TO UNPLUG THE CORD



UNPLUG YOUR CORDED TOOLS and pick up Makita's 18v X2 (36V) Lithium-Ion line up. Get the freedom you need to reach new heights with unmatched run time - you'll never look back.



36v POWER
(2) 18v BATTERIES



Learn More makitatools.com/X2

* Under Load: 13-3/4" cutting swath with .080" nylon line, approximate run time will vary according to grass conditions



DCL500Z Tool only - battery and charger not included

18v LXT® CYCLONIC CANISTER VACUUM Long Lasting Powerful Suction

- Powerful motor generates 46 CFM of suction power and 26.5" of water lift
- Up to 49 minutes of continuous operation using a 5.0Ah LXT® battery (battery not included)
- Filtration system with cyclonic separation keeps motor running at optimum performance
- Cyclonic system separates large dust particles from fine dust particles so that only fine dust particles are captured on the filter

Model DCL500Z Includes: Floor Nozzle (SH00000035), Telescoping Extension Wand (SH00000037), Crevice Nozzle (SH00000042), Shoulder Strap (166124-3), Hose (SH00000034), (SH00000032); Battery and Charger not included

Continuous Use (max, in minutes)	49 min.
Air Flow Rate	46 CFM
Static Water Lift	26.5"
Working Sound Level	64 dB(A)
Capacity (pint)	.53 pint
Battery	18V LXT® Lithium-Ion
Overall Length	13-7/8"
Net Weight (with battery)	9.4 lbs.
Shipping Weight	11 lbs.



XRM04B Bluetooth

18v LXT® BLUETOOTH® JOB SITE RADIO Bluetooth® and MP3 Compatible

- Equipped with Bluetooth® to wirelessly connect your mobile device to play music
- Menu controls to set FM mono/stereo, clock settings, volume and snooze
- Runs up to 20 hours with an 18V LXT® Lithium-Ion 5.0Ah battery and 6 hours with an 18V Compact Lithium-Ion 2.0Ah battery
- Protective bumpers are engineered for increased durability
- One auxiliary port for MP3 compatibility and one USB port for charging your mobile device

Model XRM04B Includes: Tool Only - AC Adapter (SE0000104), Antenna, AA Battery for Clock; Battery and Charger not included

Voltage	7.2-18V
Digital Tuner	FM/AM
Backlit LCD Display	Yes
iPod® Dock	Yes
AC Adaptor	Yes
Dimensions (LxWxH)	11" x 6-3/8" x 11-7/8"
Net Weight (with battery)	10.4 lbs.
Shipping Weight	10.95 lbs.



iPod® not included



XRM03 Tool only - battery and charger not included

18v LXT® JOBSITE RADIO iPod® Docking Station, MP3 Compatible

- Built-in dock works with most models of iPod® iPhones® for charging and playing music
- Menu controls to set FM mono/stereo, clock settings, loudness, snooze, and iPod® controls
- Runs 16 hours with an 18V LXT® Lithium-Ion battery and 8 hrs. with an 18V Compact Lithium-Ion battery (battery and charger sold separately)
- Protective bumpers are engineered for increased durability
- Two auxiliary ports for MP3/iPod® compatibility
- Delivers rich stereo sound from two powerful 3" side-firing speakers

Model XRM03B Includes: AC Adaptor (SE0000104), Antenna (SE0000256), AA Battery for Clock; Battery and Charger not included

Voltage	7.2-18V
Digital Tuner	FM/AM
Backlit LCD Display	Yes
iPod® Dock	Yes
AC Adaptor	Yes
Dimensions (LxWxH)	11" x 6-3/8" x 11-7/8"
Net Weight (w/battery)	10.4 lbs.
Shipping Weight	9.2 lbs.



DCM500Z Tool only - battery and charger not included

18v LXT® COFFEE MAKER Auto Drip Brewing

- Brews one 5 oz. cup of coffee in 3 min. when plugged into a power outlet; one 5 oz. cup of coffee in 7 min. when powered by a 5.0Ah 18V LXT® battery
- No paper filters needed; permanent drip filter allows grounds to be poured directly into coffee maker
- Battery adapter can be removed when using AC power
- Compact design at only 8-3/8" tall with a 3-1/2" cup clearance
- Boil dry protection automatically turns the coffee maker off if there is not enough water

Model DCM500Z Includes: Measuring Spoon, AC Power Supply Cord, Battery Holder; Battery and Charger not included

Overall Length	8-3/8"
Battery	18V LXT® Lithium-Ion
Net Weight (with battery)	3.7 lbs.
Shipping Weight	4.4 lbs.

RUN TIME



Accepts Makita 18v LXT® and Compact Lithium-Ion Batteries (not included); USB power port for charging portable electronic devices

CONTROL

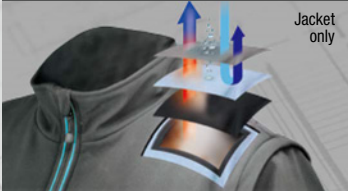

3 heat settings: high/medium/low for precise heating control

VERSATILITY



Removable zip off sleeves quickly converts the jacket into a vest

UP TO 28 HOURS OF HEAT*



Jacket only - battery and charger not included

18v LXT® HEATED JACKET (JACKET ONLY)

DCJ200ZS	SMALL
DCJ200ZM	MEDIUM
DCJ200ZL	LARGE
DCJ200ZXL	X-LARGE
DCJ200Z2XL	2X-LARGE
DCJ200Z3XL	3X-LARGE



Jacket only - battery and charger not included

18v LXT® MOSSY OAK® HEATED JACKET (JACKET ONLY)

DCJ201ZS	SMALL
DCJ201ZM	MEDIUM
DCJ201ZL	LARGE
DCJ201ZXL	X-LARGE
DCJ201Z2XL	2X-LARGE
DCJ201Z3XL	3X-LARGE



Vest only - battery and charger not included

18v LXT® HEATED VEST (VEST ONLY)

DCV200ZM	MEDIUM
DCV200ZL	LARGE
DCV200ZXL	X-LARGE
DCV200Z2XL	2X-LARGE
DCV200Z3XL	3X-LARGE

Stay Warm In Cold Harsh Job Site Environments

- 3 core heat zones (left chest, right chest, back) for optimum heat distribution
- 3 heat settings (high/ medium/ low) for precise heating control
- Features 4 pockets: zippered chest pocket and side pockets (left and right), sleeve pocket
- On/Off heat controller with 3 L.E.D. indicators

* with BL1850B on low setting

18V LXT® Heated Jacket & Mossy Oak® Heated Jacket Include: Jacket Only; Battery and Charger not included

Heat Settings	High-Medium-Low
Number of Pockets	5 (including battery pocket)
Battery	18V LXT® Lithium-Ion
Overall Length	12-7/8"
Net Weight (with battery)	3.8 lbs.
Shipping Weight	3.8 lbs.

Stay Warm In Cold Job Site Environments

- Up to 28 hours of heat using 5.0Ah LXT® battery on low setting
- 18V LXT® Heated Vest Includes:** Vest Only; Battery and Charger not included

Heat Settings	High-Medium-Low
Number of Pockets	5 (including battery pocket)
Battery	18V LXT® Lithium-Ion
Overall Length	12-7/8"
Net Weight (with battery)	3.8 lbs.
Shipping Weight	1.7 lbs.



Shown with optional tripod light stand (GM0001381)

NEW DML805

Battery and charger not included

18v LXT® CORDLESS/CORDED L.E.D. FLOOD LIGHT
L.E.D. Lights Deliver Bright and Even Lighting For Large Workspaces

- Up to 8.5 hours of continuous illumination with a 5.0Ah 18V LXT® battery on High mode (battery and charger not included)
- Up to 17 hours of continuous illumination with a 5.0Ah 18V LXT® battery on Low mode (battery and charger not included)
- L.E.D. flood light delivers either full brightness (750 lumens) on High or half brightness (450 lumens) on Low
- Extreme Protection Technology (XPT™) is engineered for improved dust and water resistance for operation in harsh conditions (only with DC power)

Model DML805 Includes: Flashlight Only; Battery and Charger not included

Run Time (max, in hours)	17
Battery	18V LXT® Lithium-Ion
Lumens	750
Overall Length	8-3/8"
Net Weight (with battery)	6.1 lbs.
Shipping Weight	6.1 lbs.



DML802

Battery and charger not included

18v LXT® L.E.D. FLASHLIGHT
Up to 21 Hours of Illumination with 5.0Ah LXT® Battery

- High-luminance single L.E.D. flashlight provides 200 lumens
- 12 position pivoting flashlight head with positive stops from 60° - 110°
- Aluminum flashlight head design for increased durability
- Metal hang hook is convenient and job site durable
- Compact and ergonomic design at only 10-3/4" long
- Only use genuine Makita batteries and chargers

Model DML802 Includes: Flashlight Only; Battery and Charger not included

Run Time (max, in hours)	21
Battery	18V LXT® Lithium-Ion
Bulb	6 LED
Lumens	200
Overall Length	10-3/4"
Net Weight (with battery)	2.1 lbs.
Shipping Weight	1.5 lbs.



DML185

Battery and charger not included

18v LXT® XENON FLASHLIGHT
Up to 7.5 Hours of Illumination with 5.0Ah LXT® Battery

- Xenon bulb for 4,500-lux brightness
- 4-position head pivots for versatility
- Compact and ergonomic design at only 11-1/8" long
- Includes shoulder strap and 2 bulbs
- Battery and charger sold separately
- Only use genuine Makita batteries and chargers

Model DML185 Includes: (2) Replacement Bulb (Xenon), 2/pk (A-90261); Battery and Charger not included

Run Time (max, in hours)	7.5
Battery	18V LXT® Lithium-Ion
Lumens	180
Bulb	Xenon
Overall Length	11-1/8"
Net Weight (with battery)	2.1 lbs.
Shipping Weight	1.2 lbs.



LXLM01

Battery and charger not included

18v LXT® L.E.D. FLASHLIGHT
Flashlight Illuminates The Job site

- 6 LED Flashlight runs up to 82.5 hours per charge from a single fully charged 18V 5.0Ah LXT® Lithium-Ion battery (battery not included)
- Compact and ergonomic design at 5-7/8" long
- Weighs only 1.3 lbs. with battery (battery not included) for reduced operator fatigue
- Hand strap for extra convenience
- Compact size ideal for work in tight spaces
- Ideal addition to any tool box
- Only use genuine Makita batteries and chargers

Model LXLM01 Includes: Flashlight Only; Battery and Charger not included

Run Time (max, in hours)	82.5
Battery	18V LXT® Lithium-Ion
Lumens	500
Bulb	6 LED
Overall Length	5-7/8"
Net Weight (with battery)	1.3 lbs.
Shipping Weight	.5 lbs.



DML184

Battery and charger not included

18v LXT® FLUORESCENT/ INCANDESCENT FLASHLIGHT
Two Modes: Fluorescent or Incandescent

- High illumination fluorescent light for extra brightness
- Long run time with up to 20 incandescent hours and 7.8 fluorescent hours per charge with a 5.0Ah battery (battery sold separately)
- Hang strap with swivel hook for extra convenience
- Compact and ergonomic design at only 17-3/4" long
- Weighs only 2 lbs. with battery (battery not included) for reduced operator fatigue
- Rubberized soft grip handle provides increased comfort on the job

Model DML184 Includes: Fluorescent Bulb (SM00000050), Light Bulb, 2/pk (A-94502); Battery and Charger not included

Run Time (max, in hours)	20
Battery	18V LXT® Lithium-Ion
Lumens	15
Bulb	Flourescent
Overall Length	17-3/4"
Net Weight (with battery)	2.2 lbs.
Shipping Weight	1.5 lbs.



NEW DML806

Battery and charger not included

18v LXT® L.E.D. LANTERN/FLASHLIGHT
Dual Purpose; Use as a Lantern or Flashlight

- Three L.E.D. lighting modes: 360° lantern, 180° lantern or flashlight
- 360° lantern mode provides 620 lumens; 180° lantern mode provides 310 lumens; flashlight mode provides 90 lumens
- 180°-360° lantern lighting allows the user to select between entire work area or specific task illumination
- Up to 11 hours of continuous illumination in 360° lantern mode with a 5.0Ah LXT® battery (battery sold separately)

Model DML806 Includes: Flashlight Only; Battery and Charger not included

Run Time (max, in hours)	59
Battery	18V LXT® Lithium-Ion
Lumens	240
Bulb	12 LED
Overall Length	14-3/8"
Net Weight (with battery)	2.1 lbs.
Shipping Weight	1.4 lbs.



NEW DML807

Battery and charger not included

18v LXT® L.E.D. LANTERN/FLASHLIGHT
Built-in USB Port

- Three L.E.D. lighting modes: 360° lantern, 180° lantern or flashlight
- 360° lantern mode provides 610 lumens; 180° lantern mode provides 300 lumens; flashlight mode provides 150 lumens
- 180°-360° lantern lighting allows the user to select between entire work area or specific task illumination
- Up to 11 hours of continuous illumination in 360° lantern mode with a 5.0Ah LXT® battery (battery sold separately)

Model DML807 Includes: Flashlight Only; Battery and Charger not included

Run Time (max, in hours)	36
Battery	18V LXT® Lithium-Ion
Lumens	300
Bulb	12 LED
Overall Length	14-1/4"
Net Weight (with battery)	2.2 lbs.
Shipping Weight	1.36 lbs.



DML801

Battery and charger not included

18v LXT® 12 L.E.D. FLASHLIGHT
Extra Bright 12 L.E.D. Flashlight Provides 240 Lumens

- Up to 17 hours of continuous illumination in 12 L.E.D. mode with a 5.0Ah 18V LXT® battery (sold separately)
- Up to 40 hours of continuous illumination in 6 L.E.D. mode with a 5.0Ah 18V LXT® battery (sold separately)
- Flashlight head folds up and down with 7 positive stops and rotates left to right for multiple lighting angles
- Metal hang hook swivels 360° and folds away for extra convenience
- 2-mode on/off switch delivers either full brightness (240 lumens) with 12 L.E.D. or half brightness (120 lumens) with 6 L.E.D.

Model DML801 Includes: Flashlight Only; Battery and Charger not included

Run Time (max, in hours)	40
Battery	18V LXT® Lithium-Ion
Lumens	240
Bulb	12 LED
Overall Length	15"
Net Weight (with battery)	2.1 lbs.
Shipping Weight	1.65 lbs.

LXT
LITHIUM-ION

POWERING
125+
TOOLS¹

¹In 2016

5.0Ah
BATTERY



NEW BL1850B
45 Minute Charge Time

4.0Ah
BATTERY



NEW BL1840B
40 Minute Charge Time

3.0Ah
BATTERY



30 Minute Charge Time
BL1830

2.0Ah
BATTERY



NEW BL1820B
25 Minute Charge Time

LESS TIME
CHARGING
MORE TIME
WORKING

3-2-Piece Cordless Combo Kits

COMPACT
LITHIUM-ION
18V POWER

BRUSHLESS

NEW **XT248R**

2.0Ah
BATTERY

- XPH06Z Brushless 1/2" Hammer Driver-Drill
- XDT08Z Brushless Impact Driver
- BL1820B (2) 18V Compact Lithium-Ion 2.0Ah Battery
- DC18RC Rapid Optimum Charger



COMPACT
LITHIUM-ION
18V POWER

NEW **CT320R**

2.0Ah
BATTERY

- XFD10R 1/2" Driver-Drill
- XDT11R Impact Driver
- DML185W Flashlight
- BL1820 (2) 18V Compact Lithium-Ion 2.0Ah Battery
- DC18RC Rapid Optimum Charger



COMPACT
LITHIUM-ION
18V POWER

NEW **CT225R**

2.0Ah
BATTERY

- XFD10Z 1/2" Hammer Driver-Drill
- XDT11Z Impact Driver
- BL1820B (2) 18V Compact Lithium-Ion 2.0Ah Battery
- DC18RC Rapid Optimum Charger



COMPACT
LITHIUM-ION
18V POWER

CT200RW

2.0Ah
BATTERY

- XFD01Z 1/2" Driver-Drill
- XDT04Z Impact Driver
- BL1820 (2) 18V Compact Lithium-Ion 2.0Ah Battery
- DC18RC Rapid Optimum Charger



Impact GOLD
Xtreme Torsion Technology



B-49616

IMPACT GOLD® 3 PC. ASSORTED (2-1/2") TORX DOUBLE-ENDED POWER BITS
Lasts up to 10X Longer than Standard Bits

- One bit with two magnetic tips for quick bit changes



B-52370

IMPACT GOLD® 38 PC. TORSION BIT SET
Designed Exclusively for High-Torque Impact Drivers

- Impact GOLD® insert bits last up to 10X longer than standard insert bits
- Mag Boost makes any power bit magnetic

Additional Impact GOLD® Accessories See pg. 96-97

Learn More makitatools.com/ImpactGold



Z
Z-TOOL
XPH10Z

COMPACT
LITHIUM-ION
18V POWER



NEW XPH10R XPT™ 2.0Ah BATTERY

18v COMPACT 1/2" HAMMER DRIVER-DRILL KIT
More Compact And 26% More RPM¹

- Makita-built 4-pole motor delivers 480 in.lbs. of Max Torque
- Variable 2-speed design (0-600 & 0-1,900 RPM) covers a wide range of drilling, driving and hammer applications
- Compact and ergonomic design at only 7-3/4" long
- Weighs only 3.4 lbs. with battery for reduced operator fatigue
- Rubberized soft grip provides increased comfort on the job
- Dual L.E.D. lights with afterglow illuminate the work area

Model XPH10R Includes: (2) 18V Compact Lithium-Ion 2.0Ah Battery (BL1820B), 18V Lithium-Ion Rapid Optimum Charger (DC18RC), Tool Case, Belt Clip

Model XPH10Z Includes: Tool Only; Battery and Charger not included

Capacities:	Steel (1/2"), Wood (1-1/2"), Masonry (1/2")
No Load Speed (var. 2 spd)	0 - 600 / 0 - 1,900 RPM
Blows Per Minute (2 speed)	0 - 9,000 / 0 - 28,500 BPM
Maximum Torque (in.lbs./N•m)	480 in.lbs./54N•m
Battery	18V Compact Lithium-Ion
Overall Length	7-3/4"
Net Weight (with battery)	3.4 lbs.
Shipping Weight	10.7 lbs.

¹ Compared to XPH01Z



Z
Z-TOOL
XFD10Z

COMPACT
LITHIUM-ION
18V POWER



NEW XFD10R XPT™ 2.0Ah BATTERY

18v COMPACT 1/2" DRIVER-DRILL KIT
More Compact And 26% More RPM²

- Makita-built 4-pole motor delivers 480 in.lbs. of Max Torque
- Mechanical 2-speed transmission (0-600 & 0-1,900 RPM) for a wide range of drilling and driving applications
- Features Extreme Protection Technology (XPT™) which is engineered to provide increased dust and water resistance in harsh job site conditions
- Dual L.E.D. lights with afterglow illuminate the work area
- Ergonomically designed handle with rubberized soft grip provides increased comfort

Model XFD10R Includes: (2) 18V Compact Lithium-Ion 2.0Ah Battery (BL1820B), 18V Lithium-Ion Rapid Optimum Charger (DC18RC), Tool Case

Model XFD10Z Includes: Tool Only; Battery and Charger not included

Capacities:	Steel (1/2"), Wood (1-1/2"), Masonry (1/2")
No Load Speed (var. 2 spd)	0 - 600 / 0 - 1,900 RPM
Maximum Torque (in.lbs./N•m)	480 in.lbs./54N•m
Battery	18V Compact Lithium-Ion
Overall Length	7-1/4"
Net Weight (with battery)	3.3 lbs.
Shipping Weight	10.6 lbs.

² Compared to XFD01Z



Z
Z-TOOL
XDT11Z

COMPACT
LITHIUM-ION
18V POWER



NEW XDT11R XPT™ 2.0Ah BATTERY

18v COMPACT IMPACT DRIVER KIT
Makita 4-Pole Motor with 4-Brush Design Delivers 26% More RPM without Decreasing Torque³

- Variable speed (0-2,900 RPM & 0-3,500 IPM) and 1,460 in.lbs. of torque for a wide range of fastening applications
- All metal gear housing for increased job site durability
- Compact and ergonomic design at only 5-3/8" long
- Weighs only 2.8 lbs. with battery for reduced operator fatigue
- Convenient one-touch 1/4" hex chuck for quick bit changes

Model XDT11R Includes: (2) 18V Compact Lithium-Ion 2.0Ah Battery (BL1820B), 18V Lithium-Ion Rapid Optimum Charger (DC18RC), Tool Case

Model XDT11Z Includes: Tool Only; Battery and Charger not included

Hex Shank	1/4"
No Load Speed (variable speed)	0 - 2,900 RPM
Impacts Per Minute (variable speed)	0 - 3,500 IPM
Maximum Torque (in.lbs./N•m)	1,460 in.lbs./165N•m
Battery	18V Compact Lithium-Ion
Overall Length	5-3/8"
Net Weight (with battery)	2.8 lbs.
Shipping Weight	10.3 lbs.

³ Compared to XDT04Z



COMPACT
LITHIUM-ION
18V POWER



XLC02RB1W 2.0Ah BATTERY

18v COMPACT VACUUM KIT
Strong Suction Power for Fast Cleaning with More Run Time

- Up to 15 minutes of continuous use from a single fully charged 18V Compact Lithium-Ion battery
- Redesigned floor nozzle for improved maneuverability and debris collection
- Strong suction power for fast and efficient cleaning
- Bagless 2-stage cloth filtration system allows for easier cleaning and quicker debris disposal
- Increased storage capacity for longer time between waste disposal

Model XLC02RB1W Includes: 18V Compact Lithium-Ion 2.0Ah Battery (BL1820B), 18V Lithium-Ion Rapid Optimum Charger (DC18RC), Extension Attachment (451424-7), Floor Nozzle (122858-8), Crevice Nozzle (451240-7), Filter (451208-3), Cloth Vacuum Filter (443060-3)

Capacity (pint)	1.3 pint
Continuous Use (max, in minutes)	15 min.
Battery	18V Compact Lithium-Ion
Overall Length	18-3/4"
Net Weight (with battery)	2.7 lbs.
Shipping Weight	6 lbs.



COMPACT
LITHIUM-ION
18V POWER

XLC02ZW Tool only - battery and charger not included

18v COMPACT VACUUM
Strong Suction Power for Fast Cleaning

- Up to 10 minutes of continuous use from a single fully charged 18V Compact Lithium-Ion battery
- Redesigned floor nozzle for improved maneuverability and debris collection
- Strong suction power for fast and efficient cleaning
- Bagless 2-stage cloth filtration system allows for easier cleaning and quicker debris disposal
- Increased storage capacity for longer time between waste disposal

Model XLC02ZW Includes: Tool Only - Extension Attachment (451424-7), Floor Nozzle (122858-8), Crevice Nozzle (451240-7), Filter (451208-3), Cloth Vacuum Filter (443060-3); Battery and Charger not included

Capacity (pint)	1.3 pint
Continuous Use (max, in minutes)	10 min.
Battery	18V Compact Lithium-Ion
Overall Length	18-3/4"
Net Weight (with battery)	2.7 lbs.
Shipping Weight	3.8 lbs.



COMPACT
LITHIUM-ION
18V POWER

XRM02W Tool only - battery and charger not included

18v COMPACT JOB SITE RADIO
MP3 Compatible for iPod® and MP3 Players

- Delivers rich stereo sound from two powerful 3" side-firing speakers
- Up to 19 hours of continuous use with BL1830 battery (battery not included)
- Protective bumper design for added durability
- 10 Preset FM/AM buttons
- One auxiliary port for MP3/iPod® compatibility
- Water-resistant construction is engineered for improved operation in harsh job site conditions

Model XRM02W Includes: Tool Only - AC Adapter (SE00000077), Antenna (SE00000033), AA Battery for Clock; Battery and Charger not included

Voltage	7.2-18V
Digital Tuner	FM/AM
Backlit LCD Display	Yes
Memory Preset	5 FM / 5 AM
AC Adaptor	Yes
Auxiliary Port	Yes
Power Source	AC or Makita slide-style and pod-style batteries
Dimensions (LxWxH)	10-1/8" x 6-3/8" x 17"
Net Weight (with battery)	10.1 lbs.
Shipping Weight	11 lbs.



COMPACT
LITHIUM-ION
18V POWER

DML185W Battery and charger not included

18v COMPACT XENON FLASHLIGHT
Xenon Light Provides Spotlight Illumination

- High illumination Xenon bulb emits at 4,500 Lux
- Up to 4 hours of continuous illumination with a 3.0Ah 18V LXT® battery (battery and charger not included)
- 4-position head pivots for greater versatility
- Compact design at only 11-1/8" long and weighs just over 2 lbs.
- Soft grip handle provides increased comfort
- An ideal addition to any gangbox or toolbox

Model DML185W Includes: Flashlight Only - battery and charger not included

Run Time (max, in hours)	4
Battery	18V LXT® Lithium-Ion
Lumens	180
Bulb	Xenon
Overall Length	11-1/8"
Net Weight (with battery)	2.1 lbs.
Shipping Weight	.82 lbs.



COMPACT
LITHIUM-ION
18V POWER

DML186W Battery and charger not included

18v COMPACT L.E.D. FLASHLIGHT
Runs up to 35 Hours on a Single Charged 18v 2.0Ah Compact Lithium-Ion Battery

- Compact design at 5-7/8" long and weighs only 1.3 lbs. with battery for reduced operator fatigue
- Hand strap for extra convenience
- Accepts Makita 18V LXT® Lithium-Ion 3.0Ah battery for even longer run time
- Compact size for work in tight spaces.
- Compact 6 L.E.D. Flashlight runs up to 35 hours per charge from a single fully charged 18V Compact Lithium-Ion battery
- An ideal addition to any gangbox or toolbox

Model DML186W Includes: Flashlight Only; Battery and Charger not included

Run Time (max, in hours)	35
Battery	18V Compact Lithium-Ion
Bulb	6 LED
Overall Length	5-7/8"
Net Weight	1.3 lbs.
Shipping Weight	.55 lbs.

CXT™
LITHIUM-ION

NEXT GENERATION

12v max CXT™
SLIDE-STYLE
LITHIUM-ION

4.0Ah
BATTERY



NEW BL1041B

2.0Ah
BATTERY



NEW BL1021B

UPGRADED
NEW L.E.D. BATTERY
CHARGE INDICATOR

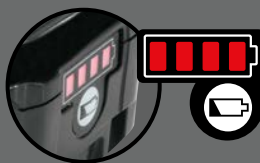

SLIDE-STYLE
COMBINING PERFORMANCE
WITH SUPERIOR ERGONOMICS
IN A COMPACT SIZE

2-Piece Cordless Combo Kits



NEW CT226RX

2.0Ah
BATTERY

- FD05Z 3/8" Driver-Drill
- DT03Z Impact Driver
- BL1021B (2) 12V max CXT™ Lithium-Ion Battery
- DC10WD CXT™ Lithium-Ion Charger



NEW CT226

1.5Ah
BATTERY

- FD05Z 3/8" Driver-Drill
- DT03Z Impact Driver
- (2) 12V max CXT™ Lithium-Ion Battery
- DC10WD CXT™ Lithium-Ion Charger



NEW CT229R

2.0Ah
BATTERY

- FD05Z 3/8" Driver-Drill
- RJ03Z Impact Driver
- BL1021B (2) 12V max CXT™ Lithium-Ion Battery
- DC10WD CXT™ Lithium-Ion Charger



NEW CT227R

2.0Ah
BATTERY

- FD05Z 3/8" Driver-Drill
- SH02Z 3-3/8" Circular Saw
- BL1021B (2) 12V max CXT™ Lithium-Ion Battery
- DC10WD CXT™ Lithium-Ion Charger

ERGONOMICS



Ergonomically designed handle with rubberized soft grip provides increased comfort

COMFORT



Weighs only 2.3 lbs. with battery for reduced operator fatigue

TECHNOLOGY



The BL™ Motor eliminates carbon brushes, enabling the BL™ Motor to run cooler and more efficiently

2-SPEED BRUSHLESS DRIVER-DRILL



DESIGN

6-1/16"

Compact and ergonomic design at only 6-1/16" long

BRUSHLESS

NEW FD07R1

12v max CXT™ BRUSHLESS 3/8" DRIVER-DRILL KIT
Compact Brushless and Ergonomic Design

- Compact and ergonomic design at only 6-1/16" long
- Weighs only 2.3 lbs. with battery for reduced operator fatigue
- BL™ Brushless Motor delivers 280 in.lbs. of Max Torque
- The BL™ Brushless Motor eliminates carbon brushes, enabling the BL Motor to run cooler and more efficiently for longer life
- Efficient BL™ Brushless motor is electronically controlled to optimize battery energy use for up to 50% longer run time per charge

Model FD07R1 Includes: (2) 12V max CXT™ Lithium-Ion 2.0Ah Battery (BL1021B), 12V max CXT™ Lithium-Ion Charger (DC10WD), Tool Case

Model FD07Z Includes: Tool Only; Battery and Charger not included

Capacities:	Steel (3/8"), Wood (1-1/8")
No Load Speed (var. 2 spd)	0 - 450 / 0 - 1,500 RPM
Maximum Torque (in.lbs.)	280 in.lbs.
Battery	12V max CXT™ Lithium-Ion
Overall Length	6-1/16"
Net Weight (with battery)	2.3 lbs.
Shipping Weight	7.2 lbs.



Z
PART TOOL
PART #122
PH04Z



NEW PH04R1

12v max CXT™ 3/8" HAMMER DRIVER-DRILL KIT
Slide Style Battery and Improved Ergonomic Grip

- Variable 2-speed design (0-450 & 0-1,700 RPM) covers a wide range of drilling and driving applications
- Makita-built motor delivers 250 in.lbs. of Max Torque
- Compact and ergonomic design at only 7-7/8" long
- Weighs only 2.5 lbs. with battery for reduced operator fatigue

Model PH04R1 Includes: (2) 12v max CXT™ Lithium-Ion 2.0Ah Battery (BL1021B), 12v max CXT™ Lithium-Ion Charger (DC10WD), Tool Case

Model PH04Z Includes: Tool Only; Battery and Charger not included

Capacities:	Steel (3/8"), Wood (13/16"), Masonry (5/16")
No Load Speed (var. 2 spd)	0 - 450 / 0 - 1,700 RPM
Impacts Per Minute (variable speed)	6,750 - 25,500 IPM
Maximum Torque (in.lbs.)	250 in.lbs.
Battery	12v max CXT™ Lithium-Ion
Overall Length	7-7/8"
Net Weight (with battery)	2.5 lbs.
Shipping Weight	8.8 lbs.



Z
PART TOOL
PART #122
PH05Z



NEW PH05R1

12v max CXT™ BRUSHLESS 3/8" HAMMER DRIVER-DRILL KIT
Compact Brushless and Ergonomic Design

- Compact and ergonomic design at only 6-5/8" long
- Weighs only 2.4 lbs. with battery for reduced operator fatigue
- BL™ Brushless Motor delivers 280 in.lbs. of Max Torque
- The BL™ Brushless Motor eliminates carbon brushes, enabling the BL Motor to run cooler and more efficiently for longer life

Model PH05R1 Includes: (2) 12v max CXT™ Lithium-Ion 2.0Ah Battery (BL1021B), 12v max CXT™ Lithium-Ion Charger (DC10WD), Tool Case

Model PH05Z Includes: Tool Only; Battery and Charger not included

Capacities:	Steel (3/8"), Wood (1-1/8"), Masonry (5/16")
No Load Speed (var. 2 spd)	0 - 450 / 0 - 1,500 RPM
Blows Per Minute (2 speed)	0 - 6,750 / 0 - 22,500 BPM
Maximum Torque (in.lbs.)	280 in.lbs.
Battery	12v max CXT™ Lithium-Ion
Overall Length	6-5/8"
Net Weight (with battery)	2.4 lbs.
Shipping Weight	7.2 lbs.



Z
PART TOOL
PART #122
FD05Z



NEW FD05R1

12v max CXT™ 3/8" DRIVER-DRILL KIT
Slide Style Battery and Improved Ergonomic Grip

- Variable 2-speed design (0-450 & 0-1,700 RPM) covers a wide range of drilling and driving applications
- Makita-built motor delivers 250 in.lbs. of Max Torque
- Ergonomically designed handle with rubberized soft grip provides increased comfort
- 12v max CXT™ slide battery design enables the tool to stand on its own for user convenience
- Compact and ergonomic design at only 7-7/16" long

Model FD05R1 Includes: (2) 12v max CXT™ Lithium-Ion 2.0Ah Battery (BL1021B), 12v max CXT™ Lithium-Ion Charger (DC10WD), Tool Case

Model FD05Z Includes: Tool Only; Battery and Charger not included

Capacities:	Steel (3/8"), Wood (13/16")
No Load Speed (var. 2 spd)	0 - 450 / 0 - 1,700 RPM
Maximum Torque (in.lbs.)	250 in.lbs.
Battery	12v max CXT™ Lithium-Ion
Overall Length	7-7/16"
Net Weight (with battery)	2.2 lbs.
Shipping Weight	8.8 lbs.



Z
PART TOOL
PART #122
FD06Z



NEW FD06R1

12v max CXT™ 1/4" HEX DRIVER-DRILL KIT
Slide Style Battery and Improved Ergonomic Grip

- Variable 2-speed design (0-450 & 0-1,700 RPM) covers a wide range of drilling and driving applications
- Makita-built motor delivers 250 in.lbs. of Max Torque
- Compact and ergonomic design at only 6-3/16" long
- Weighs only 2.1 lbs. with battery for reduced operator fatigue
- 12v slide battery design enables the tool to stand on its own for user convenience

Model FD06R1 Includes: (2) 12v max CXT™ Lithium-Ion 2.0Ah Battery (BL1021B), 12v max CXT™ Lithium-Ion Charger (DC10WD), Tool Case

Model FD06Z Includes: Tool Only; Battery and Charger not included

Capacities:	Steel (3/8"), Wood (13/16")
Hex Shank	1/4"
No Load Speed (var. 2 spd)	0 - 450 / 0 - 1,700 RPM
Maximum Torque (in.lbs.)	250 in.lbs.
Battery	12v max CXT™ Lithium-Ion
Overall Length	6-3/16"
Net Weight (with battery)	2.1 lbs.
Shipping Weight	8.8 lbs.



Z
PART TOOL
PART #122
DT03Z



NEW DT03R1

12v max CXT™ IMPACT DRIVER KIT
Slide Style Battery and Improved Ergonomic Grip

- Variable speed (0-2,600 RPM & 0-3,500 IPM) for a wide range of fastening applications
- Motor delivers 970 in.lbs. of Max Torque in an ultra compact size
- Ergonomically designed handle with rubberized soft grip provides increased comfort
- 12v slide battery design enables the tool to stand on its own for user convenience

Model DT03R1 Includes: (2) 12v max CXT™ Lithium-Ion 2.0Ah Battery (BL1021B), 12v max CXT™ Lithium-Ion Charger (DC10WD), Tool Case

Model DT03Z Includes: Tool Only; Battery and Charger not included

Hex Shank	1/4"
No Load Speed (variable speed)	0 - 2,600 RPM
Impacts Per Minute (variable speed)	0 - 3,500 IPM
Maximum Torque (in.lbs./N•m)	970 in.lbs./110N•m
Battery	12v max CXT™ Lithium-Ion
Overall Length	6"
Net Weight	2.3 lbs.
Shipping Weight	8.8 lbs.

COMPACT CUTTING



Z
PART TOOL
PART #122
SH02Z



SH02R1

12v max CXT™ 3-3/8" CIRCULAR SAW KIT
High Cutting Efficiency

- Makita-built motor delivers 1,500 RPM for faster cutting
- 3-3/8" blade delivers a maximum cutting depth of 1" for a wide range of cutting applications
- Adjustable cutting depth from 1" at 90° and 5/8" at 45°
- Tilting base for bevel cuts from 0° - 45°
- Cuts plywood, MDF, pegboard, particleboard, melamine, drywall and more
- Only use genuine Makita batteries and chargers

Model SH02R1 Includes: (2) 12v max CXT™ Lithium-Ion 2.0Ah Battery (BL1021B), 12v max CXT™ Lithium-Ion Charger (DC10WD), 3-3/8" 20T C.T. Saw Blade (A-95021)

Model SH02Z Includes: Tool Only; Battery and Charger not included

Blade Diameter	3-3/8"
Arbor (mm)	15 mm
No Load Speed	1,500 RPM
Max. Cutting Capacity (at 90°)	1"
Max. Cutting Capacity (at 45°)	5/8"
Overall Length	12-3/8"
Battery	12v max CXT™ Lithium-Ion
Net Weight (with battery)	3.5 lbs.



Z
PART TOOL
PART #122
RJ03Z



NEW RJ03R1

12v max CXT™ RECIPRO SAW KIT
Slide Style Battery and Improved Ergonomic Grip

- Variable speed motor delivers 0-3,300 strokes per minute combined with a 1/2" length stroke to provide faster cutting
- Exclusive dual-position on/off switch design allows for either paddle switch or trigger switch operation
- "Tool-less" blade change system allows for faster blade installation and removal for increased productivity; accepts both Recipro and Jig Saw blades
- Built-in L.E.D. light illuminate the work area

Model RJ03R1 Includes: (2) 12v max CXT™ Lithium-Ion 2.0Ah Battery (BL1021B), 12v max CXT™ Lithium-Ion Charger (DC10WD)

Model RJ03Z Includes: Tool Only; Battery and Charger not included

Length of Stroke	1/2"
Max. Cutting Capacity:	Pipe (2"), Wood (2")
Strokes Per Minute (variable speed)	0 - 3,300 SPM
Battery	12v max CXT™ Lithium-Ion
Overall Length	14-3/4"
Net Weight (with battery)	3 lbs.
Shipping Weight	14.5 lbs.

12v max LITHIUM-ION 3 & 2-Piece Cordless Combo Kits

LCT314W

FD02ZW 3/8" Driver-Drill
 DT01ZW Impact Driver
 LM01W L.E.D. Flashlight
 BL1014 (2) 12V max Lithium-Ion Battery
 DC10WB Lithium-Ion Charger

LCT212W

FD02ZW 3/8" Driver-Drill
 RJ01ZW Recipro Saw
 BL1014 (2) 12V max Lithium-Ion Battery
 DC10WB Lithium-Ion Charger

LCT209W

FD02ZW 3/8" Driver-Drill
 DT01ZW Impact Driver
 BL1014 (2) 12V max Lithium-Ion Battery
 DC10WB Lithium-Ion Charger

LCT208W

FD02ZW 3/8" Driver-Drill
 SH01ZW 3-3/8" Circular Saw
 BL1014 (2) 12V max Lithium-Ion Battery
 DC10WB Lithium-Ion Charger

FD02ZW

12v max LITHIUM-ION

AD02ZW

12v max LITHIUM-ION

FD02W

12v max 3/8" DRIVER-DRILL KIT
 Makita-Built Motor Delivers 200 in.lbs. of Max Torque

- Variable 2-speed design (0 - 350 & 0 - 1,300 RPM) covers a wide range of drilling and driving applications
- Ultra-compact design at only 7-7/16" long and weighs only 2.2 lbs. with battery for reduced operator fatigue
- Built-in L.E.D. light illuminates the work area
- Makita-built motor delivers 200 in.lbs. of Max Torque and 120 in.lbs. of PTI torque in an ultra compact size
- Ergonomic shape fits like a glove with even pressure

Model FD02W Includes: (2) 12V max Lithium-Ion Battery (BL1014), Lithium-Ion Charger (DC10WB), Holster (168467-9), #2 Double Ended Phillips Bit (784244-7), Tool Case

Model FD02ZW Includes: Tool Only, Battery and Charger not included

AD02W

12v max 3/8" RIGHT ANGLE DRILL KIT
 Close Quarters Drilling and Driving

- Makita-built motor delivers up to 100 in.lbs. of Max Torque
- Variable speed (0 - 800 RPM) for a wide range of drilling and driving applications
- Compact and ergonomic design at only 12-1/4" long
- Weights only 2.5 lbs. with battery for reduced operator fatigue
- Compact 3-1/2" angle head height for use in close quarters
- Ergonomic barrel grip design for added comfort

Model AD02W Includes: (2) 12V max Lithium-Ion Battery (BL1014), Lithium-Ion Charger (DC10WB), Tool Case

Model AD02ZW Includes: Tool Only, Battery and Charger not included

Capacities:	Steel (3/8"), Wood (13/16")
No Load Speed (var. 2 spd)	0 - 350 / 0 - 1,300 RPM
Maximum Torque (in.lbs./N•m)	200 in.lbs./22N•m
Battery	12V max Lithium-Ion
Overall Length	7-7/16"
Net Weight (with battery)	2.2 lbs.
Shipping Weight	8 lbs.

Capacities:	Steel (3/8"), Wood (1/2")
No Load Speed	800 RPM
Maximum Torque (in.lbs./N•m)	100 in.lbs./11N•m
Battery	12V max Lithium-Ion
Overall Length	12-1/4"
Net Weight (with battery)	2.5 lbs.
Shipping Weight	7.7 lbs.

FD01ZW

12v max LITHIUM-ION

DT01ZW

12v max LITHIUM-ION

WT01ZW

12v max LITHIUM-ION

SH01ZW

12v max LITHIUM-ION

FD01W

12v max 1/4" HEX DRIVER-DRILL KIT
 Ultra-Compact Design

- Variable 2-speed design (0-350 & 0-1,300 RPM) covers a wide range of drilling and driving applications
- Ultra-compact design at only 6-3/16" long and weighs only 2.0 lbs. with battery for reduced operator fatigue
- Convenient 1/4" hex chuck for quick bit changes
- Built-in L.E.D. light illuminates the work area
- Makita-built motor delivers 200 in.lbs. of Max Torque and 120 in.lbs. of PTI torque in an ultra compact size
- Soft grip handle provides increased comfort on the job

Model FD01W Includes: (2) 12V max Lithium-Ion Battery (BL1014), Lithium-Ion Charger (DC10WB), Holster (168467-9), #2 Double Ended Phillips Bit (784244-7), Tool Case

Model FD01ZW Includes: Tool Only, Battery and Charger not included

DT01W

12v max IMPACT DRIVER KIT
 800 in.lbs. of Max Torque in an Ultra-Compact Size

- Variable speed (0 - 2,400 RPM & 0 - 3,000 IPM) for a wide range of fastening application
- Ultra-compact design at only 6-1/8" long and weighs only 2.0 lbs. for reduced operator fatigue
- Built-in L.E.D. light illuminates the work area
- Convenient 1/4" hex chuck for quick bit changes
- Makita's proprietary hammer and anvil are made using the highest quality steel and heat hardened to last longer

Model DT01W Includes: (2) 12V max Lithium-Ion Battery (BL1014), Lithium-Ion Charger (DC10WB), Holster (168467-9), #2 Double Ended Phillips Bit (784244-7), Tool Case

Model DT01ZW Includes: Tool Only, Battery and Charger not included

WT01W

12v max 3/8" IMPACT WRENCH KIT
 Makita-Built Motor Delivers 1,000 in.lbs. of Max Torque

- Variable speed (0-2,300 RPM & 0-3,000 IPM) for a wide range of fastening applications
- Ultra-compact design at only 6-3/8" long and weighs only 2.1 lbs. with battery for reduced operator fatigue
- Built-in L.E.D. light illuminates the work area
- Soft grip handle provides increased comfort on the job
- Makita's proprietary hammer and anvil are made using the highest quality steel and heat hardened to last longer
- Only use genuine Makita batteries and chargers

Model WT01W Includes: (2) 12V max Lithium-Ion Battery (BL1014), Lithium-Ion Charger (DC10WB), Tool Case

Model WT01ZW Includes: Tool Only, Battery and Charger not included

SH01W

12v max 3-3/8" CIRCULAR SAW
 Up to 70 Cuts of 1/2" x 12" Plywood Per Charge

- Makita-built motor delivers 1,400 RPM for faster cutting
- 3-3/8" blade delivers a maximum cutting depth of 1" for a wide range of cutting applications
- Adjustable cutting depth from 1" at 90° and 5/8" at 45°
- Tilting base for bevel cuts from 0° - 45°
- Cuts Plywood, MDF, Pegboard, Particleboard, Melamine, Drywall and more

Model SH01W Includes: (2) 12V max Lithium-Ion Battery (BL1014), Lithium-Ion Charger (DC10WB), 3-3/8" 20T C.T. Saw Blade (A-95021)

Model SH01ZW Includes: Tool Only, Battery and Charger not included

Hex Shank	1/4"
Capacities:	Steel (3/8"), Wood (13/16")
No Load Speed (var. 2 spd)	0 - 350 / 0 - 1,300 RPM
Maximum Torque (in.lbs./N•m)	200 in.lbs./22N•m
Battery	12V max Lithium-Ion
Overall Length	6-3/16"
Net Weight (with battery)	2 lbs.
Shipping Weight	8 lbs.

Hex Shank	1/4"
No Load Speed (variable speed)	0 - 2,400 RPM
Impacts Per Minute (variable speed)	0 - 3,000 IPM
Maximum Torque (in.lbs./N•m)	800 in.lbs./90N•m
Battery	12V max Lithium-Ion
Overall Length	6-1/8"
Net Weight (with battery)	2 lbs.
Shipping Weight	8 lbs.

Square Drive	3/8"
No Load Speed (RPM)	2,300
Impacts Per Minute (variable speed)	0 - 3,000 IPM
Maximum Torque (in.lbs.)	1,000 in.lbs.
Battery	12V max Lithium-Ion
Overall Length	6-3/8"
Net Weight (with battery)	2.1 lbs.
Shipping Weight	8 lbs.

Blade Diameter	3-3/8"
Arbor (mm)	15 mm
No Load Speed	1,400 RPM
Max. Cutting Capacities:	90° (1"), 45° (5/8")
Battery	12V max Lithium-Ion
Overall Length	11-3/4"
Net Weight (with battery)	3.3 lbs.
Shipping Weight	5.61 lbs.



Z
Z-TOOL
Z-TOOL
CC01ZW

12V max LITHIUM-ION

CC01W

12v max 3-3/8" TILE/ GLASS SAW KIT
Up to 70 Cuts on a Single Charge¹

- Makita-built motor delivers 1,400 RPM for fast and powerful cutting
- 3-3/8" blade delivers a maximum cutting depth of 1" for a wide range of cutting applications
- Compact and ergonomic design at only 11-3/8" long
- Weighs only 3.7 lbs. (with battery) for reduced operator fatigue
- Nickel-plated tilting base for bevel cuts from 0° to 45°
- Adjustable cutting depth up to 1" at 90° and 5/8" at 45°

Model CC01W Includes: (2) 12V max Lithium-Ion Battery (BL1014), Lithium-Ion Charger (DC10WB), Tile Saw Blade
Model CC01ZW Includes: Tool Only; Battery and Charger not included

Blade Diameter	3-3/8"
Arbor (mm)	15 mm
No Load Speed	1,400 RPM
Max. Cut Depth:	90° (1"), 45° (5/8")
Battery	12V max Lithium-Ion
Overall Length	11-3/4"
Net Weight (with battery)	3.7 lbs.

¹ Cutting glass 11-3/4" wide and 3/8" thick with a diamond blade



Z
Z-TOOL
Z-TOOL
RJ01ZW

12V max LITHIUM-ION

RJ01W

12v max RECIPRO SAW KIT
25% Faster Cutting Speed on 1-1/2" PVC Pipe

- Variable speed motor delivers 0-3,300 strokes per minute combined with a 1/2" length stroke to provide faster cutting
- Makita-exclusive dual-position on/off switch allows for either paddle switch or trigger switch operation
- "Tool-less" blade change system allows for faster blade installation and removal for increased productivity
- Compact design at 14" long and only 2.6 lbs. for convenient operation
- Built-in L.E.D. light illuminate the work area

Model RJ01W Includes: (2) 12V max Lithium-Ion Battery (BL1014), Lithium-Ion Charger (DC10WB)
Model RJ01ZW Includes: Tool Only; Battery and Charger not included

Length of Stroke	1/2"
Max. Cutting Capacities:	Pipe (2"), Wood (2")
Strokes Per Minute (variable speed)	0 - 3,300 SPM
Battery	12V max Lithium-Ion
Overall Length	14"
Net Weight (with battery)	2.6 lbs.
Shipping Weight	4.65 lbs.



Z
Z-TOOL
Z-TOOL
VJ01ZW

12V max LITHIUM-ION

VJ01W

12v max JIG SAW KIT
Fast Cutting, Weighs Only 3.7 lbs.

- Makita-built variable speed motor delivers 0-2,400 strokes per minute
- 3 orbital settings plus straight cutting for use in a wide range of materials
- Compact, well-balanced design at only 3.7 lbs. (w/battery) for reduced operator fatigue
- Through-the-body dust port for use with a vacuum provides efficient dust management
- Built-in dust blower clears the line of cut for increased accuracy

Model VJ01W Includes: (2) 12V max Lithium-Ion Battery (BL1014), Lithium-Ion Charger (DC10WB), 4-1/8" 9TPI Jig Saw Blade (792529-7-1), Tool Case
Model VJ01ZW Includes: Tool Only; Battery and Charger not included

Length of Stroke	11/16"
Max. Cutting Capacities:	Wood (2-9/16"), Mild Steel (1/16"), Aluminum (5/32")
Strokes Per Minute (variable speed)	0 - 2,400 SPM
Blade Shank	"T" Tang
Battery	12V max Lithium-Ion
Overall Length	9-1/8"
Net Weight (with battery)	3.7 lbs.
Shipping Weight	10.4 lbs.



12V max LITHIUM-ION

LC01Z

12v max VACUUM
Quick Clean-Ups with Strong Suction Power

- Strong suction power for fast and efficient cleaning
- Redesigned floor nozzle for improved maneuverability and debris collection
- Bagless 2-stage cloth filtration system allows for easier cleaning and quicker debris disposal
- Increased storage capacity for longer time between waste disposal
- Up to 12 minutes of continuous use from a single fully charged 12V max Lithium-Ion battery

Model LC01ZW Includes: Tool Only - Extension Attachment (451424-7), Floor Nozzle (122861-9), Crevice Nozzle (416041-0), Filter (451208-3), Cloth Vacuum Filter (443060-3); Battery and Charger not included

Capacity (pint)	1.25 pint
Continuous Use (max, in minutes)	12 min.
Battery	12V max Lithium-Ion
Overall Length	17-7/8"
Net Weight (with battery)	1.9 lbs.
Shipping Weight	4 lbs.

7.2v LITHIUM-ION



12V max LITHIUM-ION

LC05

12v max VACUUM, BUILT-IN BATTERY
Strong Suction Power

- Powered by a 12V max Lithium-Ion built-in battery with AC adapter power supply
- Features 3 vacuuming modes: low, high or turbo
- Up to 12 minutes of continuous use in low mode from a fully charged battery
- L.E.D. light indicates when to charge battery and when dust bag is full
- Easy to open hinged front cover for convenient dust bag removal and replacement
- Suction port is angled for easy floor cleaning

Model LC05 Includes: Paper Dust Bag, Cloth Dust Bag, Pipe, Sash Nozzle Holder, Sash Nozzle, Nozzle, AC Adapter

Capacity (pint)	1.05 pint
Continuous Use (max, in minutes)	12 min.
Battery	12V max Lithium-Ion
Overall Length	38-5/8"
Net Weight (with battery)	1.9 lbs.
Shipping Weight	4.3 lbs.



12V max LITHIUM-ION

ML102

12v max L.E.D. LANTERN/ FLASHLIGHT
Ultra-Compact L.E.D. Lantern/Flashlight Runs up to 8 Hours Per Charge

- Can be used as a Lantern or Flashlight by turning the selector knob to change the internal L.E.D. direction
- Conical reflector provides 360° illumination
- Enhanced dust and drip-proof design allows for use in outdoor applications
- High-luminance single L.E.D. provides up to 100 lumens
- Compact design at only 7-1/8" long and weighs only 0.9 lbs. with battery (battery not included)

Model ML102 Includes: Flashlight only; Battery and Charger not included

Bulb	1 LED
Brightness (Lux)	800 Lux
Run Time (max, in hours)	9
Battery	12V max Lithium-Ion
Battery Charge Time (minutes)	60
Overall Length	4-3/4"
Net Weight	.55 lbs.
Shipping Weight	.75 lbs.



7.2V LITHIUM-ION

TD021DSE

7.2v LITHIUM-ION 1/4" HEX IMPACT DRIVER KIT
Variable Speed for Controlled Operation

- Makita-built motor delivers 195 in.lbs. of Max Torque in a compact design
- Variable speed (0-2,300 RPM & 0-3,000 IPM) for a wide range of fastening applications
- Ergonomically located forward/reverse switch for convenient adjustment of rotational speed for precise screw driving
- Operates in straight or pistol grip positions
- Electric brake for maximum productivity

Model TD021DSE Includes: (2) 7.2V Lithium-Ion Battery (BL7010), 10.8V and 7.2V LXT[®] Lithium-Ion Charger (DC10WA), Tool Case

Hex Shank	1/4"
No Load Speed (2 spd)	0/2,300 RPM
Maximum Torque (in.lbs.)	195 in.lbs.
Impacts Per Minute (variable speed)	0 - 3,000 IPM
Battery	7.2V Compact Lithium-Ion
Overall Length (pistol)	8-7/8"
Overall Length (in-line)	11"
Net Weight (with battery)	1.2 lbs.
Shipping Weight	6.1 lbs.



7.2V LITHIUM-ION

DF010DSE

7.2v LITHIUM-ION DRIVER-DRILL
Auto-Stop Clutch Delivers Exact Torque Control

- Makita-built motor delivers 44 in.lbs. of Max Torque in a compact design
- Built-in L.E.D. light flashes when it is time to recharge the battery
- 2-speed design (200 RPM and 600 RPM) for high or low torque applications
- Operates in straight or pistol grip positions
- 21 clutch settings and drill mode for added fastening control (fastening torque range: 2.7 in.lbs. - 27.0 in.lbs.)

Model DF010DSE Includes: (2) 7.2V Lithium-Ion Battery (BL7010), 10.8V and 7.2V LXT[®] Lithium-Ion Charger (DC10WA), #2 Double Ended Phillips Bit (784244-7), #1 Double Ended Phillips Bit (784245-5), Tool Case

Capacities:	Steel (3/16"), Wood (1/4")
Hex Shank	1/4"
No Load Speed (2 spd)	200/650 RPM
Maximum Torque (in.lbs./N•m)	44 in.lbs./5N•m
Battery	7.2V Compact Lithium-Ion
Overall Length (pistol)	8-7/8"
Overall Length (in-line)	11"
Net Weight (with battery)	1.2 lbs.
Shipping Weight	5.5 lbs.

18v Lithium-Ion

UPGRADED

NEW L.E.D. BATTERY CHARGE INDICATOR

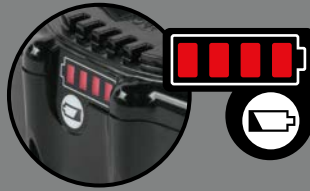

18v LXT® LITHIUM-ION 5.0Ah BATTERY
Reaches Full Charge in 45 Minutes or Less

BL1850B (1-Pack)

BL1850B-2 (2-Pack)



5.0Ah
BATTERY



NEW
45 Minute
Charge Time

18v LXT® LITHIUM-ION 4.0Ah BATTERY
Reaches Full Charge in 40 Minutes or Less

BL1840B (1-Pack)

BL1840B-2 (2-Pack)



4.0Ah
BATTERY



NEW
40 Minute
Charge Time

18v LXT® LITHIUM-ION 3.0Ah BATTERY¹
Reaches Full Charge in 30 Minutes or Less

BL1830 (1-Pack)

BL1830-2 (2-Pack)



3.0Ah
BATTERY



NEW
30 Minute
Charge Time

¹ Does not feature L.E.D. indicator

18v COMPACT LITHIUM-ION 2.0Ah BATTERY
Reaches Full Charge in 25 Minutes or Less

BL1820B (1-Pack)

BL1820B-2 (2-Pack)



2.0Ah
BATTERY



NEW
25 Minute
Charge Time

**18v LITHIUM-ION
RAPID OPTIMUM CHARGER**
Rapid Charging

DC18RC



**18v LITHIUM-ION DUAL PORT
RAPID OPTIMUM CHARGER**
Charges 2 Batteries Simultaneously

DC18RD



18v LITHIUM-ION 4-PORT CHARGER
Will Accommodate Up To 4 Makita®
18v Lithium-Ion Batteries

DC18SF

• Charges 2 batteries at a time



**18v LITHIUM-ION OPTIMUM
AUTOMOTIVE CHARGER²**
Charge 18v LXT® Batteries in Your Auto or Truck

DC18SE

² Not a rapid charger



36v Lithium-Ion

36v LITHIUM-ION BATTERY
30 Minute Charge Time³

BL3626 **2.6Ah** BATTERY



36v CHARGER
Charges Makita 36v
Lithium-Ion Battery
(BL3622A) in 60 Minutes

DC36WA

Battery BL3622A must only be used with 36V
Optimum Charger (DC36WA)

36v LITHIUM-ION BATTERY
60 Minute Charge Time³

BL3622A **2.2Ah** BATTERY

³When used with Makita's Rapid Optimum Charger (DC36WA)

14.4v Lithium-Ion

14.4v LITHIUM-ION BATTERY
22 Minutes Fast Charging

BL1430

DC18RC
Rapid Optimum
Charger

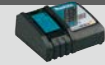

DC18SF
Rapid Optimum
4-Port Charger



DC18RD
Rapid Optimum
Dual Port Charger



DC18SE
Automotive
Charger



12v max Lithium-Ion

12v max CXT™ LITHIUM-ION 4.0Ah BATTERY
Slide-Style Battery

BL1041B **4.0Ah** BATTERY



12v max CXT™ LITHIUM-ION CHARGER
Charges 12v max CXT™
Slide-Style Batteries

DC10WD

• Charges a 12v max CXT™ Lithium-Ion
4.0Ah battery in only 130 minutes
• Charges a 12v max CXT™ Lithium-Ion
2.0Ah battery in only 70 minutes

12v max CXT™ LITHIUM-ION 2.0Ah BATTERY
Slide-Style Battery

BL1021B **2.0Ah** BATTERY

12v max LITHIUM-ION BATTERY
Pod-Style Battery

BL1014

LITHIUM-ION CHARGER
Charges 7.2v to 12v max
Batteries in 50 Minutes

DC10WB

• Also charges 10.8V
Lithium-Ion batteries

7.2v Lithium-Ion

7.2v LITHIUM-ION BATTERY
60 Minute Charge Time

BL7010

LITHIUM-ION CHARGER
Charges 7.2v to 12v max
Batteries in 50 Minutes

DC10WB

• Also charges 10.8V
Lithium-Ion batteries



CONCRETE

AVT

Advanced
ANTI VIBRATION TECHNOLOGY

**70 lb. Advanced AVT®
Breaker Hammer**
HM1812

**DEMOLITION
HAMMERS**



pg. 38-39

**ROTARY
HAMMERS**



pgs. 39-40

**CORDLESS
ROTARY HAMMERS**



pg. 41

**POWER
CUTTERS**



pg. 43

**PLANERS /
MASONRY SAWS**



pg. 44

ACCESSORIES



pgs. 99-105



INCLUDES
(1) Hex Wrench
(1) Hammer Cart
(2) Flat Chisels
(2) Bull Points



INCLUDES
(1) Hex Wrench
(1) Hammer Cart
(2) Flat Chisels
(2) Bull Points



NEW HM1812X3

70 lb. ADVANCED AVT® BREAKER HAMMER
Hits Like Air Without the Vibration

- Efficient 15 AMP motor with improved hammer mechanism delivers 53.9 ft.lbs./72.8 joules of impact energy
- Advanced AVT® is a mechanical counterbalance, vibration absorbing housing and rubberized fixed handles designed to more effectively reduce vibration
- Soft start is designed to suppress start-up reaction for greater accuracy on start up
- L.E.D. light indicates electrical failure or notifies the user approximately 8 hours before brushes need to be replaced

Model HM1812X3 Includes: Hex Wrench (783203-B), Premium Hammer Cart (T-02892), (2) 1-1/8" x 20-1/2" Flat Chisel, 1-1/8" Hex (D-21369), (2) 16" Self Sharpening Bull Point, 1-1/8" Hex (B-45559)

HM1810X3

70 lb. AVT® BREAKER HAMMER
Anti-Vibration Technology for 2X Less Vibration

- Efficient 15 AMP motor with improved hammer mechanism delivers 46.5 ft.lbs. of impact energy
- Anti-Vibration Technology is an internal counterbalance system that greatly reduces vibration
- Fixed movement handles for more control and better accuracy
- AC/DC switch for use with alternative power source
- L.E.D. power light indicates switch failure or cord damage

Model HM1810X3 Includes: Hex Wrench (783203-B), Premium Hammer Cart (T-02892), (2) 1-1/8" x 20-1/2" Flat Chisel, 1-1/8" Hex (D-21369), (2) 20-1/2" Bull Point, 1-1/8" Hex (D-21353)

HM1317CB

42 lb. AVT® DEMOLITION HAMMER
Anti-Vibration Technology for 2X Less Vibration

- Powerful 14 AMP motor delivers 25.7 ft.lbs. of impact energy to handle the most demanding applications
- Variable speed control dial enables user to match the speed to the application for greater versatility
- L.E.D. service light notifies the user approximately 8 hours before the brushes need to be replaced
- L.E.D. power light indicates switch failure or cord damage
- Rubberized ergonomic soft grip provides more comfort

Model HM1317CB Includes: 20-1/2" Bull Point, 1-1/8" Hex (D-21353), Tool Case w/Wheels

HM1500B

42 lb. DEMOLITION HAMMER
Rugged All Metal Housing for Longer Tool Life

- Powerful 13.5 AMP motor delivers 18.4 ft.lbs. of impact energy
- Pneumatic compression system automatically adjusts air in the cylinder to minimize power loss and deliver unmatched power-to-weight ratio
- "Soft no-load" function automatically reduces the speed of the motor when idling
- Makita Motor Advantage engineered for more power and longer tool life
- Automatic brush cut-off protects commutator from damage for longer tool life

Model HM1500B Includes: Steel Tool Case

Blows Per Minute	870 BPM
Impact Energy	53.9 ft.lbs. / 72.8 J
AMPS	15
Noise Level	106 dB
Vibration (m/s²)	6.5
Cord Length (ft)	16.4'
Overall Length	33-1/4"
Net Weight	69.1 lbs.
Shipping Weight	140 lbs.
Bit Type	1-1/8" Hex

Blows Per Minute	1,100 BPM
Impact Energy	46.5 ft.lbs. / 63 J
AMPS	15
Noise Level	107 dB
Vibration (m/s²)	9
Cord Length (ft)	16.4'
Overall Length	32-1/2"
Net Weight	71.3 lbs.
Shipping Weight	141.3 lbs.
Bit Type	1-1/8" Hex

Blows Per Minute (variable speed)	730 - 1,450 BPM
Impact Energy	25.7 / 34.9 J
AMPS	14
Noise Level	101 dB
Vibration (m/s²)	7
Cord Length (ft)	16.4'
Overall Length	32-1/2"
Net Weight	41.9 lbs.
Shipping Weight	60.39 lbs.
Bit Type	1-1/8" Hex

Blows Per Minute	1,300 BPM
Impact Energy	18.4 / 25 J
AMPS	13.5
Noise Level	101 dB
Vibration (m/s²)	26
Cord Length (ft)	17"
Overall Length	31-3/4"
Net Weight	44.1 lbs.
Shipping Weight	66.7 lbs.
Bit Type	1-1/8" Hex



HM1307CB

35 lb. DEMOLITION HAMMER
Electronic Controller for Operator Convenience

- Powerful 14 AMP motor delivers 25.7 lbs. of impact energy to handle the most demanding applications
- Constant Speed Control automatically applies additional power to the motor to maintain consistent speed under load for the most challenging jobs
- Soft Start suppresses start-up reaction for smoother start-ups and better accuracy
- L.E.D. Service Light notifies the user approximately 8 hours before the brushes need to be replaced
- L.E.D. Power Lights indicate switch failure or cord damage

Model HM1307CB Includes: 20-1/2" Bull Point, 1-1/8" Hex (D-21353), Tool Case

HM1214C

27 lb. AVT® DEMOLITION HAMMER
Anti-Vibration Technology for 2X Less Vibration

- Powerful 14 AMP motor delivers 19 ft.lbs. of impact energy to handle the most demanding applications
- Anti-Vibration Technology is an internal counterbalance system that greatly reduces vibration
- Constant speed control automatically applies additional power to the motor to maintain speed under load
- Soft start suppresses start-up reaction for more precision and better accuracy

Model HM1214C Includes: Side Handle (135283-4), 12" Bull Point, SDS-MAX (751423-A), Hammer Bit Grease (194683-7), Tool Case

HM1203C

20 lb. DEMOLITION HAMMER
Compact Power with Less Weight

- Powerful 14 AMP motor delivers 18.8 ft.lbs. of impact energy to handle the most demanding applications
- Constant speed control automatically applies additional power to the motor to maintain speed under load to complete the most challenging jobs
- Variable speed control dial enables user to match the speed to the application for greater versatility
- Soft start suppresses start-up reaction for precision and better accuracy
- L.E.D. service light notifies the user approximately 8 hours before the brushes need to be replaced

Model HM1203C Includes: Side Handle (135283-4), 12" Bull Point, SDS-MAX (751423-A), Hammer Bit Grease (194683-7), Tool Case

HM1211B

20 lb. DEMOLITION HAMMER
Air Cushion Design for Powerful Performance

- Powerful 10 AMP motor for fast and efficient operation
- Comfortable rubber D-shaped grip side handle absorbs vibration; secures in four positions for operator comfort
- One-touch latch bit retainer for quick bit changes
- Automatic brush cut-off protects commutator from damage for longer tool life
- Factory grease packed for reduced maintenance
- AC/DC switch for use with alternative power source

Model HM1211B Includes: Hex Wrench (783202-0), Tool Case

Blows Per Minute (variable speed)	730 - 1,450 BPM
Impact Energy	25.7 / 34.9 J
AMPS	14
Noise Level	101 dB
Vibration (m/s²)	12
Overall Length	32-1/2"
Net Weight	38.2 lbs.
Shipping Weight	56.422 lbs.
Bit Type	1-1/8" Hex

Blows Per Minute (variable speed)	950 - 1,900 BPM
Impact Energy	19 / 25.7 J
AMPS	14
Noise Level	101 dB
Vibration (m/s²)	8
Overall Length	27-1/2"
Net Weight	27.1 lbs.
Shipping Weight	46.284 lbs.
Bit Type	Accepts SDS-MAX

Blows Per Minute (variable speed)	950 - 1,900 BPM
Impact Energy	18.8 / 25.5 J
AMPS	14
Noise Level	95 dB
Vibration (m/s²)	15.5
Overall Length	22-3/4"
Net Weight	20.3 lbs.
Shipping Weight	36 lbs.
Bit Type	Accepts SDS-MAX

Blows Per Minute	2,000 BPM
Impact Energy	10.5 ft.lbs. / 14.2 J
AMPS	10
Noise Level	95 dB
Overall Length	19-5/16"
Net Weight	20.7 lbs.
Shipping Weight	33 lbs.
Bit Type	3/4" Hex - 21/32" Round



HM1111C

17 lb. AVT® DEMOLITION HAMMER
Anti-Vibration Technology for
2X Less Vibration

- Powerful 14 AMP motor delivers 12.7 ft.lbs. of impact energy to handle the most demanding applications
- Anti-Vibration Technology is an internal counterbalance system that greatly reduces vibration for increased user comfort and greater productivity
- Detached rear handle is spring loaded to provide less vibration and more control
- Constant speed control automatically applies additional power to the motor to maintain speed under load to complete the most challenging jobs

Model HM1111C Includes: Side Handle (151769-0), Hammer Bit Grease (194683-7), CLOTH F/WIPING OIL (443122-7), 12" Bull Point, SDS-MAX (751423-A), Tool Case

Blows Per Minute (variable speed)	1,100 - 2,650 BPM
Impact Energy	12.7 ft.lbs. / 17.2 J
AMPS	14
Vibration (m/s ²)	8
Overall Length	20-3/4"
Net Weight	17.7 lbs.
Shipping Weight	28.6 lbs.
Bit Type	Accepts SDS-MAX



HM0870C

11 lb. DEMOLITION HAMMER
Compact Power with Less Weight

- Powerful 10 AMP motor delivers 8.4 ft.lbs. of impact energy to handle the most demanding applications
- Constant speed control automatically applies additional power to the motor to maintain speed under load to complete the most challenging jobs
- Soft start suppresses start-up reaction for better accuracy
- L.E.D. service light notifies the user approximately 8 hours before the brushes need to be replaced
- L.E.D. power light indicates switch failure or cord damage
- Variable speed control dial enables user to match the speed to the application for greater versatility

Model HM0870C Includes: Side Handle (135283-4), Hammer Bit Grease (194683-7), Tool Case

Blows Per Minute (variable speed)	1,100 - 2,650 BPM
Impact Energy	8.4 ft.lbs. / 11.4 J
AMPS	10
Vibration (m/s ²)	11
Overall Length	17-3/4"
Net Weight	11.1 lbs.
Shipping Weight	18.5 lbs.
Bit Type	Accepts SDS-MAX



HM0810B

11 lb. DEMOLITION HAMMER
Ideal for Light Chiseling, Chipping
and Scaling

- Compact with less weight for improved control
- Soft rubber grip side handle minimizes vibration and swivels 360° for operator convenience
- Innovative anti-vibration spring is positioned between tool body and rear handle for reduced operator fatigue
- One-touch tool retainer action for easy accessory installation and removal
- Makita Motor Advantage engineered for more power and longer tool life
- Extended life brushes are longer for more work between service intervals and less downtime

Model HM0810B Includes: Hex Wrench (783202-0), Tool Case

Blows Per Minute	2,900 BPM
Impact Energy	5.6 ft.lbs. / 7.6 J
AMPS	8.3
Vibration (m/s ²)	8
Overall Length	16-5/8"
Net Weight	12.8 lbs.
Shipping Weight	19.4 lbs.
Bit Type	3/4" Hex - 21/32" Round



HK1810

POWER SCRAPER
Versatile Tool for Scraping and
Tile Removal

- Air cushion hammering for longer tool life
- Quick change bit retainer for easy changes
- Automatic brush cut-off protects commutator from damage
- Factory grease packed for reduced maintenance
- All-ball bearing construction for longer tool life
- Accepts Makita Small bits

Model HK1810 Includes: 1-3/16" x 6" Scaling Chisel, Makita Small Shank (B-07331), 2" x 6" Scaling Chisel, Makita Small Shank (B-07347), 8-3/4" Bull Point, Makita Small Shank (B-06921), Dust Cover (423154-0), Tool Case

Blows Per Minute (variable speed)	0 - 3,200 BPM
Impact Energy	2.9 ft.lbs. / 3.9 J
AMPS	4.5
Vibration (m/s ²)	13.5
Overall Length	12-3/8"
Net Weight	7.1 lbs.
Shipping Weight	13.7 lbs.
Bit Type	Makita small

ROTARY HAMMERS



HR5212C

2" ADVANCED AVT® ROTARY HAMMER
Advanced Anti-Vibration Technology
for Significantly Less Vibration

- Powerful 15 AMP motor delivers 14 ft.lbs. / 19 J. of impact energy
- Advanced AVT® is an air actuated counterbalance, vibration absorbing housing and impact bolt damper spring that more effectively reduces vibration
- Electronic Controller is a feature package that provides constant speed control, soft start, soft no-load and variable speed

Model HR5212C Includes: Depth Rod, HR4013C (331955-1), Hammer Bit Grease (194683-7), Cloth F/Wiping Oil (443122-7), D-handle (417003-1), Straight Handle (454781-2) (454781-2), Straight Handle Assembly (135629-4) (135629-4), Accessory Case

AMPS	15
Capacities: Concrete Drilling	2"
Concrete Drilling w/ Core Bit	6-1/4"
Impact Energy	19 J / 14 ft.lbs.
Vibration (m/s ²)	9
Blows Per Minute (variable speed)	1,100 - 2,250 BPM
No Load Speed (variable speed)	130 - 260 RPM
Overall Length	23-1/2"
Cord Length (ft)	16.4'
Net Weight	26.2 lbs.
Shipping Weight	42 lbs.
Bit Type	Accepts SDS-MAX



HR4510C

1-3/4" AVT® ROTARY HAMMER
Anti-Vibration Technology for
2X Less Vibration

- Powerful 13.5 AMP motor delivers 9.2 ft.lbs. of impact energy to handle the most demanding applications
- Constant speed control automatically applies additional power to the motor to maintain speed under load to complete the most challenging jobs
- Soft start suppresses start-up reaction for increased accuracy
- L.E.D. service light notifies the user approximately 8 hours before the brushes need to be replaced
- L.E.D. power lights indicate switch failure or cord damage

Model HR4510C Includes: Side Handle (151769-0), D-handle (417003-1), Depth Gauge (321248-4), Hammer Bit Grease (194683-7), Tool Case

AMPS	13.5
Capacities: Concrete Drilling	1-3/4"
Concrete Drilling w/ Core Bit	5"
Impact Energy	12.5 J / 9.2 ft.lbs.
Vibration (m/s ²)	9.5
Blows Per Minute (variable speed)	1,250 - 2,750 BPM
No Load Speed (variable speed)	130 - 280 RPM
Overall Length	18"
Cord Length (ft)	16.4'
Net Weight	19.6 lbs.
Shipping Weight	35 lbs.
Bit Type	Accepts SDS-MAX



HR4013C

1-9/16" ADVANCED AVT® ROTARY HAMMER
Advanced Anti-Vibration Technology
for Significantly Less Vibration

- Powerful 11 AMP motor delivers 8.4 ft.lbs. / 11.4 J. of impact energy to handle the most demanding applications
- Advanced AVT® is an air actuated counterbalance, vibration absorbing housing and impact bolt damper spring that more effectively reduces vibration
- Electronic Controller is a feature package that provides constant speed control, soft start, soft no-load and variable speed

Model HR4013C Includes: D-Handle Assembly, HR4013C (196792-8), Depth Rod, HR4013C (331955-1), Side Handle Assembly (123138-5), Hammer Bit Grease (194683-7), Cloth F/Wiping Oil (443122-7), Accessory Case

AMPS	11
Capacities: Concrete Drilling	1-9/16"
Concrete Drilling w/ Core Bit	4-1/8"
Impact Energy	11.4 J / 8.4 ft.lbs.
Vibration (m/s ²)	5
Blows Per Minute (variable speed)	1,450 - 2,900 BPM
No Load Speed (variable speed)	250 - 500 RPM
Overall Length	18-11/16"
Cord Length (ft)	15.6'
Net Weight	15.1 lbs.
Shipping Weight	27.8 lbs.
Bit Type	Accepts SDS-MAX



HR4002

1-9/16" ROTARY HAMMER
Sequential Impact Timing for Up to
50% Faster Drilling

- Powerful 10 AMP motor delivers 4.6 ft.lbs. of impact energy
- 2-mode operation for "Hammering Only" or "Hammering with Rotation"
- Rubberized ergonomic soft grip provides more comfort
- "No hammering when idling" functions helps increase tool life
- One-touch sliding chuck for quick bit changes
- Torque limiting clutch engineered to prevent gear damage by automatically disengaging gears if the bit binds

Model HR4002 Includes: Side Handle (158131-0), Depth Gauge (321248-4), Hammer Bit Grease (194683-7), Tool Case

AMPS	10
Capacities: Concrete Drilling	1-9/16"
Concrete Drilling w/ Core Bit	4-1/8"
Impact Energy	6.2 J / 4.6 ft.lbs.
Vibration (m/s ²)	17.5
Blows Per Minute	2,500 BPM
No Load Speed	680 RPM
Overall Length	18"
Cord Length (ft)	9.8'
Net Weight	14.6 lbs.
Shipping Weight	26.89 lbs.
Bit Type	Accepts SDS-MAX



HR5000



2" ROTARY HAMMER Air Cushion Design for Hard Hitting Action

- All ball-and-needle bearing construction for longer tool life
- Powerful 11 AMP motor for the most demanding applications
- Built-in clutch reduces gear damage by disengaging gears if the bit binds
- 2-mode operation for "Hammering Only" or "Hammering with Rotation" for multiple applications
- Sequential impact timing delivers timed hammering during rotation to minimize overlapping bit impacts resulting in up to 50% faster drilling

Model HR5000 Includes: Hex Wrench (783202-0), Hex Wrench (783203-8), Wrench (783204-6), Tool Case

HR4041C



1-9/16" ROTARY HAMMER Electronic Controller for Operator Convenience

- Powerful 12 AMP motor delivers 6.8 ft.lbs. of impact energy
- Constant speed control automatically applies additional power to the motor to maintain speed under load
- Soft start suppresses start-up reaction for increased accuracy
- Variable speed control dial enables user to match the speed to the application
- "No hammering while idling" helps increase tool life.
- Torque limiting clutch engineered to prevent gear damage by automatically disengaging gears

Model HR4041C Includes: Depth Gauge (321248-4), Side Handle (416549-4), Tool Case



HR3210C



1-1/4" AVT® ROTARY HAMMER Anti-Vibration Technology for 2X Less Vibration

- Powerful 8.2 AMP motor delivers 4.7 ft.lbs. of impact energy
- Constant speed control automatically applies additional power to the motor to maintain speed under load
- Soft start suppresses start-up reaction for more precision and better accuracy
- L.E.D. service light notifies the user approximately 8 hours before the brushes need to be replaced
- L.E.D. power light indicates switch failure or cord damage

Model HR3210C Includes: Side Handle (151769-0), Depth Gauge (321248-4), Hammer Bit Grease (194683-7), Tool Case

HR2811F



1-1/8" ROTARY HAMMER Torque Limiting Clutch Engineered to Prevent Gear Damage

- Powerful 7.0 AMP motor delivers 2.1 ft.lbs. of impact energy
- L.E.D. light illuminates drilling surface for more productivity in low light applications
- 3-mode operation for "Rotation Only", "Hammering with Rotation" or "Hammering Only"
- "No hammering when idling" function helps increase tool life
- Ergonomic "D-shaped" handle with rubberized soft grip for increased comfort

Model HR2811F Includes: Depth Gauge (324219-0), Side Handle (154842-5), Tool Case

AMPS	11
Capacities: Concrete Drilling	2"
Concrete Drilling w/ Core Bit	5-7/8"
Impact Energy	11.8 J / 8.7 ft.lbs.
Vibration (m/s ²)	25
Blows Per Minute	2,100 BPM
No Load Speed	260 RPM
Overall Length	18-3/4"
Cord Length (ft)	8.2'
Net Weight	21.8 lbs.
Shipping Weight	35 lbs.
Bit Type	Accepts Spline shank

AMPS	12
Capacities: Concrete Drilling	1-9/16"
Concrete Drilling w/ Core Bit	4-5/8"
Impact Energy	9.2 J / 6.8 ft.lbs.
Vibration (m/s ²)	15
Blows Per Minute (variable speed)	1,300 - 2,600 BPM
No Load Speed (variable speed)	230 - 460 RPM
Overall Length	16-7/8"
Cord Length (ft)	16.4'
Net Weight	14.8 lbs.
Shipping Weight	20.3 lbs.
Bit Type	Accepts Spline shank

AMPS	8.2
Capacities: Concrete Drilling	1-1/4"
Concrete Drilling w/ Core Bit	3-1/2"
Impact Energy	5.5 J / 4.1 ft.lbs.
Vibration (m/s ²)	10
Blows Per Minute (variable speed)	1,650 - 3,300 BPM
No Load Speed (variable speed)	315 - 630 RPM
Overall Length	15-5/8"
Cord Length (ft)	16.4'
Net Weight	11.4 lbs.
Shipping Weight	19.84 lbs.
Bit Type	Accepts SDS-PLUS

AMPS	7
Capacities: Concrete Drilling	1-1/8"
Concrete Drilling w/ Core Bit	3-1/8"
Impact Energy	2.9 J / 2.1
Vibration (m/s ²)	15
Blows Per Minute (variable speed)	0 - 4,500 BPM
No Load Speed (variable speed)	0 - 1,100 RPM
Overall Length	12-5/8"
Cord Length (ft)	8.2'
Net Weight	7.7 lbs.
Shipping Weight	11.8 lbs.
Bit Type	Accepts SDS-PLUS



HR2641



1" AVT® ROTARY HAMMER Anti-Vibration Technology for 2X Less Vibration

- Powerful 8 AMP motor delivers 2.1 ft.lbs./2.9 J. of impact energy
- Anti-Vibration Technology (AVT®) is an internal counterbalance system and impact bolt damper spring that greatly reduces vibration
- Torque limiting clutch engineered to prevent gear damage
- Recessed 3-mode function selector is located below gear housing for improved durability
- Retractable tool hook secures the tool when not in use

Model HR2641 Includes: Handle, LXF01CW (451749-9), Depth Gauge, HR2611F, HR2621 (331886-4), Tool Case

HR2475



1" ROTARY HAMMER Torque Limiting Clutch Engineered to Prevent Gear Damage

- Powerful 7.0 AMP motor delivers 2 ft.lbs. of impact energy
- 3-mode operation for "Rotation Only", "Hammering with Rotation" or "Hammering Only"
- Variable speed trigger enables user to match the speed to the application for greater versatility
- Ergonomic "D-shaped" handle with rubberized soft grip for increased comfort
- One-touch sliding chuck for quick bit changes

Model HR2475 Includes: Side Handle (158057-6), Depth Gauge (324219-0), Tool Case

HR2611F



1" AVT® ROTARY HAMMER, ACCEPTS SDS-PLUS Anti-Vibration Technology for 2X Less Vibration

- Powerful 7 AMP motor delivers 2.1 ft.lbs. of impact energy to handle the most demanding applications
- Anti-Vibration Technology (AVT®) is an internal counterbalance system that greatly reduces vibration
- Integrated damper spring at the base of the impact bolt is engineered to absorb impact vibrations from the drill bit
- L.E.D. light illuminates drilling surface for more productivity in low light applications
- Recessed hammer function selector located below gear housing for improved durability

Model HR2611F Includes: Handle, LXF01CW (451749-9), Depth Gauge, HR2611F, HR2621 (331886-4), Tool Case

HR1830F



11/16" ROTARY HAMMER Compact with Less Weight (4.2 lbs.)

- Powerful 4.2 AMP motor delivers .9 ft.lbs. of impact energy
- L.E.D. light illuminates drilling surface for more productivity in low light applications
- Torque limiting clutch engineered to prevent gear damage
- 2-mode operation for "Rotation Only", "Hammering with Rotation"
- One-touch sliding chuck for quick bit changes

Model HR1830F Includes: Depth Gauge (415486-9), Side Handle (154842-5), Tool Case

AMPS	8
Capacities: Concrete Drilling	1"
Concrete Drilling w/ Core Bit	3-1/8"
Impact Energy	2.9 J / 2.1 ft.lbs.
Vibration (m/s ²)	11.5
Blows Per Minute (variable speed)	0 - 4,500 BPM
No Load Speed (variable speed)	0 - 1,100 RPM
Overall Length	16-5/8"
Cord Length (ft)	13.1'
Net Weight	7.1 lbs.
Shipping Weight	11.55 lbs.
Bit Type	Accepts SDS-PLUS

AMPS	7
Capacities: Concrete Drilling	1"
Concrete Drilling w/ Core Bit	3-1/8"
Impact Energy	2.7 J / 2
Vibration (m/s ²)	15.5
Blows Per Minute (variable speed)	0 - 4,500 BPM
No Load Speed (variable speed)	0 - 1,100 RPM
Overall Length	16-7/8"
Cord Length (ft)	13.1'
Net Weight	6.6 lbs.
Shipping Weight	11.9 lbs.
Bit Type	Accepts SDS-PLUS

AMPS	7
Capacities: Concrete Drilling	1"
Concrete Drilling w/ Core Bit	2-11/16"
Impact Energy	2.9 J / 2.1 ft.lbs.
Vibration (m/s ²)	11.5
Blows Per Minute (variable speed)	0 - 4,600 BPM
No Load Speed (variable speed)	0 - 1,200 RPM
Overall Length	15-1/8"
Cord Length (ft)	13.1'
Net Weight	6.6 lbs.
Shipping Weight	11.7 lbs.
Bit Type	Accepts SDS-PLUS

AMPS	4.2
Capacities: Concrete Drilling	11/16"
Concrete Drilling w/ Core Bit	
Impact Energy	1.2 J, .9 ft.lbs.
Vibration (m/s ²)	14
Blows Per Minute (variable speed)	0 - 5,000 BPM
No Load Speed (variable speed)	0 - 1,500 RPM
Overall Length	10-7/8"
Cord Length (ft)	8.2'
Net Weight	4.2 lbs.
Shipping Weight	11 lbs.
Bit Type	Accepts SDS-PLUS



LXT
BRUSHLESS

XRH01Z

Tool only - battery and charger not included

18v LXT® BRUSHLESS 1" ROTARY HAMMER
Efficient BL™ Brushless Motor

- Efficient BL™ Brushless motor is electronically controlled to optimize battery energy use for up to 50% longer run time per charge
- The BL™ Brushless Motor eliminates carbon brushes, enabling the BL™ Motor to run cooler and more efficiently for longer life
- Variable speed trigger enables user to match the speed to application for greater versatility
- Multiple Chisel Positions has 40 different positions to align tool more comfortably with the application

Model XRH01Z Includes: Tool Only - Side Handle (158057-6), Depth Gauge (324219-0); Battery and Charger not included

Capacities:	Concrete (1"), Steel (1/2"), Wood (1-1/16")
No Load Speed (variable speed)	0 - 950 RPM
Blows Per Minute (variable speed)	0 - 4,700 BPM
Impact Energy (Joules)	1.9 J
Bit Type	Accepts SDS-PLUS
Battery	18V LXT® Lithium-Ion
Overall Length	12-7/8"
Net Weight (with battery)	7.2 lbs.
Shipping Weight	7.1 lbs.



LXT
BRUSHLESS

XRH011X

18v LXT® BRUSHLESS 1" ROTARY HAMMER KIT
Built-on HEPA Vacuum

- The built-on vacuum attachment captures concrete dust during drilling and is activated by the tool for operator convenience
- Vacuum powered by separate motor to maintain tool drilling performance, and provide a 2-second delay to capture remaining concrete dust
- Efficient HEPA filtration system captures 99.75% of particulates .3 microns and larger
- Efficient BL™ Brushless motor is electronically controlled to optimize battery energy use for up to 50% longer run time per charge

Model XRH011X Includes: (2) 18V LXT® Lithium-Ion 3.0Ah Battery (BL1830), 18V Lithium-Ion Rapid Optimum Charger (DC18RC), Dust Collection Attachment w/ HEPA Filter (DX01), Side Handle (158057-6), Depth Gauge (324219-0), Tool Bag

Model XRH012XV Includes: HEPA Vacuum (DX01), Tool Bag; battery and charger not included

Capacities:	Concrete (1"), Steel (1/2"), Wood (1-1/16")
No Load Speed (variable speed)	0 - 950 RPM
Blows Per Minute (variable speed)	0 - 4,700 BPM
Impact Energy (Joules)	1.9 J
Bit Type	Accepts SDS-PLUS
Battery	18V LXT® Lithium-Ion
Overall Length	14-5/8"
Net Weight (with battery)	10.2 lbs.
Shipping Weight	19.4 lbs.

BL
MOTOR

UP TO **50%**
LONGER
RUN TIME

INCREASED
POWER & SPEED

LONGER LIFE
BRUSHLESS MOTOR

Learn More makitatools.com/LXTBrushless



18v X2 LXT® 36v

XRH05Z

Tool only - battery and charger not included

18v X2 LXT® 1" ROTARY HAMMER
18 Volt Solution for Corded Power Demands

- Two 18V LXT® Lithium-Ion batteries deliver the power and run time for corded demands without leaving the 18V LXT® platform
- Makita-built motor delivers 0-1,250 RPM, 0-5,000 BPM and 3.0 Joules of impact energy for fast drilling
- Vibration-absorbing handle engineered for increased operator comfort
- Built-in L.E.D. light illuminates the work area
- 3-Mode operation for "Rotation Only", "Hammering with Rotation" or "Hammering Only"

Model XRH05Z Includes: Tool Only - Side Handle (450990-1), Depth Gauge (324219-0), Tool Bag; Battery and Charger not included

Capacities:	Concrete (1"), Steel (1/2"), Wood (1-1/4")
No Load Speed (variable speed)	0 - 1,250 RPM
Blows Per Minute (variable speed)	0 - 5,000 BPM
Impact Energy (Joules)	3 J
Bit Type	Accepts SDS-PLUS
Battery	2X 18V LXT® Lithium-Ion
Overall Length	13-3/4"
Net Weight (with battery)	9.3 lbs.
Shipping Weight	12.7 lbs.



HRH01

36v 1" ROTARY HAMMER KIT
Corded Speed & Power Without the Cord

- Makita-built motor delivers 0 - 1,200 RPM & 0 - 4,800 BPM
- Ergonomically designed vibration absorbing handle
- 3-mode operation for "Rotation Only", "Hammering with Rotation" or "Hammering Only" for multiple applications
- One-touch sliding chuck for quick bit changes
- Torque Limiting Clutch engineered to prevent gear damage by automatically disengaging gears if the bit binds

Model HRH01 Includes: (2) 36V Lithium-Ion Battery (BL3626), 36V Rapid Optimum Charger (DC36RA), Side Handle (450990-1), Depth Gauge (324219-0), Tool Bag

Capacities:	Concrete (1"), Steel (1/2"), Wood (1-1/4")
No Load Speed (variable speed)	0 - 1,200 RPM
Blows Per Minute (variable speed)	0 - 4,800 BPM
Impact Energy (Joules)	3 J
Bit Type	Accepts SDS-PLUS
Battery	36V LXT® Lithium-Ion
Overall Length	14-1/4"
Net Weight (with battery)	9.9 lbs.
Shipping Weight	26.5 lbs.



XRH04

18v LXT® 7/8" ROTARY HAMMER KIT
Compact D-Handle Grip Design

- Makita-built variable speed motor delivers 0-1,100 RPM and 0-4,000 BPM
- 3-mode operation for "Rotation Only", "Hammering with Rotation" or "Hammering Only" for multiple applications
- Built-in clutch reduces gear damage by automatically disengaging gears if bit binds
- Faster drilling with synchronized RPM and BPM

Model XRH04 Includes: (2) 18V LXT® Lithium-Ion 3.0Ah Battery (BL1830), 18V Lithium-Ion Rapid Optimum Charger (DC18RC), Side Handle (158057-6), Depth Gauge (324219-0), Tool Bag

Model XRH04Z Includes: Tool Only; Battery and Charger not included

Capacities:	Concrete (7/8"), Steel (1/2"), Wood (1")
No Load Speed (variable speed)	0 - 1,100 RPM
Blows Per Minute (variable speed)	0 - 4,000 BPM
Impact Energy (Joules)	1.9 J
Bit Type	Accepts SDS-PLUS
Battery	18V LXT® Lithium-Ion
Overall Length	16-3/8"
Net Weight (with battery)	7.7 lbs.
Shipping Weight	16.2 lbs.



XRH03

18v LXT® 7/8" ROTARY HAMMER KIT
Ergonomic Handle Design

- Makita-built variable speed motor delivers 0 - 1,100 RPM & 0 - 4,000 BPM
- 3-mode operation for "Rotation Only", "Hammering with Rotation" or "Hammering Only" for multiple applications
- Large 2-finger variable speed trigger for added convenience
- Faster drilling with synchronized RPM and BPM

Model XRH03 Includes: (2) 18V LXT® Lithium-Ion 3.0Ah Battery (BL1830), 18V Lithium-Ion Rapid Optimum Charger (DC18RC), Side Handle (158057-6), Depth Gauge (324219-0), Tool Bag

Model XRH03Z Includes: Tool Only; Battery and Charger not included

Capacities:	Concrete (1/2"), Steel (1"), Wood (7/8")
No Load Speed (variable speed)	0 - 1,100 RPM
Blows Per Minute (variable speed)	0 - 4,000 BPM
Impact Energy (Joules)	1.9 J
Bit Type	Accepts SDS-PLUS
Battery	18V LXT® Lithium-Ion
Overall Length	14-1/8"
Net Weight (with battery)	7.7 lbs.
Shipping Weight	16 lbs.



HP2070F



3/4" HAMMER DRILL "Hammering with Rotation" or "Rotation Only"

- Powerful 8.2 AMP motor for heavy duty use
- 2-mode operation for "hammering with rotation" or "rotation only"
- Large trigger switch and 360° swivel side handle for maneuverability
- Built-in clutch reduces gear damage by disengaging gears if bit binds
- Ball bearing construction for longer tool life
- L.E.D. light illuminates the work area

Model HP2070F Includes: Side Handle (152521-9), Chuck Key (763430-3), Depth Gauge (324219-0), Tool Case



HP2050

3/4" HAMMER DRILL "Hammering with Rotation" or "Rotation Only"

- Powerful 6.6 AMP motor for the most demanding jobs
- Conveniently located 2-mode switch allows for fast mode changes
- 2-speed, variable speed (0-1,200 & 0-2,900 RPM) with variable speed control dial
- Built-in clutch reduces gear damage by disengaging gears if bit binds
- Less weight (5.6 lbs.) for reduced operator fatigue

Model HP2050 Includes: Side Handle (153503-4), Depth Gauge (324219-0), Chuck Key (763430-3), Tool Case



HP2050F



3/4" HAMMER DRILL "Hammering with Rotation" or "Rotation Only"

- Powerful 6.6 AMP motor for the most demanding jobs
- Conveniently located 2-mode switch allows for fast mode changes
- 2-speed, variable speed (0-1,200 & 0-2,900 RPM) with variable speed control dial
- Built-in clutch reduces gear damage by disengaging gears if bit binds
- Less weight (5.6 lbs.) for reduced operator fatigue
- L.E.D. light illuminates the work area

Model HP2050F Includes: Side Handle (153503-4), Depth Gauge (324219-0), Chuck Key (763430-3), Tool Case



HP2010N

3/4" HAMMER DRILL Industrial Metal Gear Housing for Durability

- 2-speed gear change for ideal speed and power
- Variable speed switch for easy starting of holes
- Depth gauge for "drop-in" type anchors
- Powerful 6.0 AMP motor for continuous use
- All ball bearing construction for long tool life
- Adjustable side handle for greater control

Model HP2010N Includes: 1/2" Drill Chuck (763047-2), Chuck Key (798341-3), Side Handle (122428-3), Depth Gauge (321059-7), Tool Case

Capacities: Concrete Drilling Steel: low, high Wood: low, high	3/4" 5/8", 5/16" 1-9/16", 1"
No Load Speed (var. 2 spd)	0 - 1,200 / 0 - 2,900 RPM
Blows Per Minute (2 speed)	0 - 24,000 / 0 - 58,000 BPM
AMPS	8.2
Chuck Size	1/2"
Overall Length	14-1/4"
Net Weight	5.3 lbs.
Shipping Weight	9.55 lbs.

Capacities: Concrete Drilling Steel: low, high Wood: low, high	3/4" 1/2", 5/16" 1-9/16", 1"
No Load Speed (var. 2 spd)	0 - 1,200 / 0 - 2,900 RPM
Blows Per Minute (2 speed)	0 - 24,000 / 0 - 58,000 BPM
AMPS	6.6
Chuck Size	1/2"
Overall Length	14-1/4"
Net Weight	5.6 lbs.
Shipping Weight	9 lbs.

Capacities: Concrete Drilling Steel: low, high Wood: low, high	3/4" 1/2", 5/16" 1-9/16", 1"
No Load Speed (var. 2 spd)	0 - 1,200 / 0 - 2,900 RPM
Blows Per Minute (2 speed)	0 - 24,000 / 0 - 58,000 BPM
AMPS	6.6
Chuck Size	1/2"
Overall Length	14-1/4"
Net Weight	5.6 lbs.
Shipping Weight	8.8 lbs.

Capacities: Concrete Drilling Steel: low, high Wood: low, high	3/4", 1/2" 1/2", 1/4" 1-1/2", 3/4"
No Load Speed (var. 2 spd)	0 - 900 / 0 - 2,300 RPM
Blows Per Minute (2 speed)	0 - 18,000 / 0 - 46,000 BPM
AMPS	6
Chuck Size	1/2"
Overall Length	13-3/4"
Net Weight	6.4 lbs.
Shipping Weight	11.6 lbs.



HP1641K

5/8" HAMMER DRILL, WITH KEYLESS CHUCK Industrial Keyless Chuck; Includes Tool Case

- 2-mode operation "rotation only" or "hammering with rotation" for multiple applications
- Powerful 6.0 AMP motor for the most demanding applications
- Lightweight (4.3 lbs.) with large drilling capacity
- Soft grip handle provides increased comfort on the job
- All ball bearing construction for longer tool life
- Recessed lock-on button for continuous use

Model HP1641K Includes: Side Handle (153503-4), Depth Gauge (324219-0), Keyless Drill Chuck (766017-0), Tool Case

Capacities: Concrete Drilling Steel: low, high Wood: low, high	5/8" 1/2" 1-3/16"
No Load Speed (variable speed)	0 - 2,800 RPM
Blows Per Minute (variable speed)	0 - 44,800 BPM
AMPS	6
Chuck Size	1/2"
Overall Length	11-7/8"
Net Weight	4.3 lbs.
Shipping Weight	8.8 lbs.



HP1640

5/8" HAMMER DRILL Lightweight (4.4 lbs.) with Large Drilling Capacity

- Powerful 6.0 AMP motor for the most demanding applications
- 2-mode operation "rotation only" or "hammering with rotation" for multiple applications
- Soft grip handle provides increased comfort on the job
- All ball bearing construction for longer tool life
- Recessed lock-on button for continuous use

Model HP1640 Includes: Drill Chuck (192541-1), Chuck Key (763440-0), Side Handle (153503-4), Depth Gauge (324219-0)

Capacities: Concrete Drilling Steel: low, high Wood: low, high	5/8" 1/2" 1-3/16"
No Load Speed (variable speed)	0 - 2,800 RPM
Blows Per Minute (variable speed)	0 - 44,800 BPM
AMPS	6
Chuck Size	1/2"
Overall Length	11-7/8"
Net Weight	4.4 lbs.
Shipping Weight	6 lbs.



4114

14" SJS™ ANGLE CUTTER Built in Dust Port for Reduced Dust and Debris when Connected to a Vacuum

- Powerful 15.0 AMP motor delivers 3,800 RPM for the most demanding applications
- SJS™ technology is a mechanical clutch system that helps prevent motor and gear damage by allowing the drive shaft to slip
- Removable base for a closer edge-to-edge cut
- Rubberized handle for increased comfort
- Built-in vacuum attachment port and rubber shield reduces dust and debris
- AC/DC switch for use with alternative power source

Model 4114 Includes: Socket Wrench (782210-8)

Arbor	1"
Max. Cutting Depth: 14" diamond blade 14" cut-off wheel	5" 5"
No Load Speed	3,800 RPM
AMPS	15
Overall Length	26-1/2"
Net Weight	23.8 lbs.
Shipping Weight	30.4 lbs.

Diamond Blades

Segmented Rim

Segment slots help deliver a faster cooler cut in multiple applications



Blade Diameter	Material	Part #
12"	Cured Concrete, Block, Brick	A-94720
12"	Concrete, Asphalt	T-01264
14"	Asphalt, Sand Stone Green Concrete	A-94655
14"	Concrete, Asphalt	T-01270
14"	Cured Concrete Block, Brick	A-94736
14"	Cured Concrete Block, Brick	A-94932 ¹
14"	Concrete, Asphalt, Granite	T-02537
NEW 14"	Ferrous Metal	A-96229
16"	Asphalt, Sand Stone Green Concrete	A-94661
16"	Cured Concrete, Block, Brick	A-94742
16"	Concrete, Asphalt	T-01286

¹ Contractor Pack (3-Pack)

Turbo Rim

Constant contact with material delivers a smoother finish than segmented blades



Blade Diameter	Material	Part #
14"	Cured Concrete, Fire Brick	A-94627



EK8100

16" 81 cc POWER CUTTER
Capacity Performance 16" Power Cutter with 5.6 HP/81 cc Engine

- Improved deco-valve and metering spring for precise fuel regulation
- Ignition coil with start support function for easier start ups
- On-Off-choke operation on a single lever for operator convenience
- Five stage filtration system with advanced directional air flow, for better saw performance
- SLR Muffler recycles un-burned fuel vapor for reduced scavenging-losses and up to 15% improved fuel consumption

Model EK8100 Includes: Universal Wrench (941-719-140), Torx Wrench (940-827-000), Carburetor Screwdriver (944-340-001), Adapter Ring (20mm to 1") (394-228-121), 16" Abrasive Cut-Off Wheel, Masonry (966-161-020)

Engine Displacement (cu.in./cc)	4.9 cu.in. (81 cc)
Engine (max power)	5.6 HP/4.2 kW
No Load Speed/Max. Spindle Speed	9,350 / 3,820 RPM
Fuel Mixture	50:1
Fuel Tank Capacity	37 oz.
Arbor w/ Adaptor	20mm/1" adaptor
Max. Cutting Depth	5-3/4"
Dry Weight	23.3 lbs.
Shipping Weight	31.7 lbs.



EK7651H

14" 76 cc MM4® 4-STROKE POWER CUTTER
No Oil Mixing Simplifies Operation and Prevents Piston Seizure Due to Improper Mixing

- Eliminates the need for separate mixed oil/fuel can
- Lower noise at 93.2dB(A) and smoother idle for continuous operation
- Automatic engine decompression valve is engineered into the cam gear to reduce pull-start force by 40%

Model EK7651H Includes: Torx Wrench (782025-3), Screwdriver (783012-5), Adapter Ring (20mm to 1") (394-228-121), Tool Kit (195488-8), Oil Bottle (195532-1), Water Supply Kit (195533-9), 13/16 Wrench (941-719-132) (941-719-132)

Engine Displacement (cu.in./cc)	4.61 cu.in. (75.6 cc)
Engine (max power)	4.1 HP/3 kW
No Load Speed/Max. Spindle Speed	9,100 / 4,300 RPM
Fuel Type	Unleaded gas
Fuel Tank Capacity	37 oz.
Arbor w/ Adaptor	20mm/1" adaptor
Max. Cutting Depth	4-13/16"
Dry Weight	28.3 lbs.
Shipping Weight	35.2 lbs.



EK7301

14" 73 cc POWER CUTTER
Powerful Performance with 5.1 HP/73 cc. Engine

- Improved decompression valve and metering spring for precise fuel regulation
- Ignition coil with start support function for easier start-ups
- On-Off-choke operation on a single lever for operator convenience
- Five stage filtration system with advanced directional air flow, for better saw performance
- Starter grip decompression valve for faster starting
- Improved ignition system with large flywheel and rare earth magnets create more efficient power

Model EK7301 Includes: Torx Wrench (940-827-000), Adapter Ring (20mm to 1") (394-228-121), Universal Wrench (941-719-140), Carburetor Screwdriver (944-340-001)

Engine Displacement (cu.in./cc)	4.5 cu.in. (73 cc)
Engine (max power)	5.1 HP/3.8 kW
No Load Speed/Max. Spindle Speed	9,350 / 4,300 RPM
Fuel Mixture	50:1
Fuel Tank Capacity	37 oz.
Arbor w/ Adaptor	20mm/1" adaptor
Max. Cutting Depth	4-13/16"
Dry Weight	22 lbs.
Shipping Weight	29.3 lbs.



EK6101

14" 61 cc POWER CUTTER
Compact Performance at Only 19.6 lbs with 4.4 HP/61 cc Engine

- Stratified Air Scavenging (SAS) recovers 75% of unburned fuel and reduces fuel consumption by 20%
- Cyclonic air Intake delivers more air, more efficiently and increases air filter life by discarding 90% of larger debris
- Start capacitor with spring assisted recoil stores electrical energy resulting in significantly less pull start force
- Sliding front engine mounts help absorb vibration by detaching when cutting pressure is applied
- Smaller hub and drive wheel assembly increases maximum cutting depth to 5-1/8"

Model EK6101 Includes: Universal Wrench (941-719-140), Torx Wrench (940-827-000), Carburetor Screwdriver (944-340-001), Adapter Ring (20mm to 1") (315-228-120)

Engine Displacement (cu.in./cc)	3.7 cu.in. (61 cc)
Engine (max power)	4.4 HP/3.2 kW
No Load Speed/Max. Spindle Speed	9,850 / 4,400 RPM
Fuel Mixture	50:1
Fuel Tank Capacity	23.6 oz.
Arbor w/ Adaptor	20mm/1" adaptor
Max. Cutting Depth	5-1/8"
Dry Weight	19.6 lbs.
Shipping Weight	23.8 lbs.

Power Cutter Accessories

2.6 Gallon Pressurized Water Tank

Description	Part #
Water Tank	988-394-610

Model	Part#
DPC6410, DPC7310, DPC7311, DPC7321, EK7301, DPC8112	326-173-081
DPC7331, EK7301, DPC8132, EK8100	395-173-081
DPC7310, DPC7311	394-173-030
EK7651H	195945-6

DPC6410, DPC7310, DPC7311, DPC7321, DPC8112	394-173-010
DPC7331, DPC8132, EK7301, EK8100	395-173-011
EK7651H	442165-6

DPC6410, DPC7310, DPC7311, DPC7321, DPC8112	394-173-020
DPC7331, DPC8132, EK7301, EK8100	395-173-020
EK7651H	424399-3

DPC7331, EK7301, EK8100	957-173-110
-------------------------	-------------

DPC7331, EK7301, EK8100	957-173-110
-------------------------	-------------

Description	Part #
Torx Wrench	940-827-000

2-Cycle Synthetic Engine Oil (All 2-Cycle Models)

Size	Qty./Pkg.	Part #
2.6 oz.	1	T-00745
2.6 oz.	48	T-00745-48
6.4 oz.	1	T-00739
6.4 oz.	48	T-00739-48

Dolly & Attachments

- Comes completely assembled
- Depth-wheel weighted for greater stability
- "Tool-less" attachment - saw to dolly
- Quick adjusting ratchet system

Description	Model	Part #
Dolly & Gravity Feed Tank	EK7301, EK8100	DT2010 ²
Angled Gas Filler	EK7301, EK8100	010-114-040
Water Attachment Kit		394-365-630

Dolly & Gravity Feed Tank	EK7651H	DT4000
Water Attachment Kit		195533-9

² Use with Water Attachment Kit #394-365-630

Description	Part #
Torx Wrench	940-827-000

4-Stroke Engine Oil (All 4-Stroke Models)

Description	Size	Qty.	Part #
10W-30 Engine Oil	2.7 oz.	1	195826-4
	2.7 oz.	48	195826-4-48
	6.7 oz.	1	T-02484
	6.7 oz.	12	T-02490

MM4
4-STROKE ENGINE

REDUCES COST

ONE CAN FOR ALL YOUR GAS POWERED EQUIPMENT



ADVANTAGES

Get lower emissions, less noise and reduced operating costs.

Makita 4-stroke engines have measurably lower emissions and noise than traditional 2-stroke engines.

Lower fuel consumption at .45 gallons per hour.

Reduced exhaust and intake carbon build-up for longer cylinder life.

Learn More makitatools.com/MM4



PERFORMANCE



Five-Stage Filter System

with Advanced Directional Air Flow ensures clean air for added performance and long engine life



SJS™II

GA5040X1

5" SJS™II ANGLE GRINDER WITH TUCK POINT GUARD
5" Dust Extraction Tuck Point Guard and Diamond Blade

- Powerful 10.0 AMP motor delivers more output and 11,000 RPM
- SJS™II provides a leaf spring and cam gear drive mechanism that is engineered to reduce vibration for increased operator comfort during extended use
- Includes 5" dust extraction tuck point guard for clean and accurate tuck pointing and cutting
- Labyrinth construction seals and protects the motor and bearings from dust and debris for longer tool life

Model GA5040X1 Includes: 5" Dust Extracting Tuck Point Guard (196845-3), Inner Flange (224399-1), Lock Nut Wrench (782412-6), 5" Dual Sandwich Diamond Tuck Point Blade (A-96017), 5" Tool-less Wheel Guard (123145-8), Side Handle (162258-0)

Wheel Diameter	5"
AMPS	10
No Load Speed	11,000 RPM
Spindle Thread	5/8" - 11 UNC
Lock-On: Yes	Lock-Off: No
Grinder Switch Type	Body grip/slide
Overall Length	11-7/8"
Net Weight	5.4 lbs.
Shipping Weight	12 lbs.



SJS™II

GA5042CX1

HIGH POWER 12 AMP

5" SJS™II HIGH-POWER GRINDER WITH TUCK POINT GUARD
5" Dust Extraction Tuck Point Guard and Diamond Blade

- Powerful 12.0 AMP motor delivers more output and variable (2,800 - 11,000) RPM
- SJS™II provides a leaf spring and cam gear drive mechanism that is engineered to reduce vibration for increased operator comfort during extended use
- Includes a 5" dust extraction tuck point guard for clean and accurate tuck pointing and cutting

Model GA5042CX1 Includes: 5" Dust Extracting Tuck Point Guard (196845-3), Inner Flange (224399-1), Lock Nut Wrench (782412-6), 5" Dual Sandwich Diamond Tuck Point Blade (A-96017), 5" Tool-less Wheel Guard (123145-8), Lock Nut (224568-4)

Wheel Diameter	5"
AMPS	12
No Load Speed (variable speed)	2,800 - 11,000 RPM
Spindle Thread	5/8" - 11 UNC
Lock-On: Yes	Lock-Off: No
Grinder Switch Type	Body grip/slide
Overall Length	11-7/8"
Net Weight	5.4 lbs.
Shipping Weight	13 lbs.

SMOOTH OPERATOR



Concrete Planer
Accessories

Diamond Cup Wheels



Size	Description	Model	Part #
5"	Segmented rim for fast material removal	PC5000C, PC5001C	A-95009
5"	Continuous Rim For a smooth finish		A-94998
4-3/8"	Continuous rim for a smooth finish		792289-1
4-3/8"	Segmented for fast material removal	PC1100	724907-1A

PC5000C

5" CONCRETE PLANER
Electronic Controller for Operator Convenience

- Powerful 10 AMP motor delivers more output and 10,500 RPM
- Constant Speed Control automatically applies additional power to the motor
- Soft start suppresses start-up reaction for more precision and longer tool life
- Electronic current limiter helps protect the motor from overload
- Anti-restart prevents accidental start up after power loss
- Large two-finger trigger switch with lock-on for continuous operation

Model PC5000C Includes: 5" Diamond Cup Wheel, Segmented Rim (A-95009), Lock Nut Wrench (782425-7), Hex Wrench (783203-8), Dust Bag (122853-8), Brush Set (194921-7), Steel Tool Case

Wheel Diameter	5"
No Load Speed	10,000 RPM
AMPS	10
Overall Length	17-1/8"
Net Weight	8.9 lbs.
Shipping Weight	8.9 lbs.



PC5001C

5" CONCRETE PLANER
Adjustable Front Roller for Consistent Planing Depth

- Powerful 10.0 AMP motor delivers more output and 10,500 RPM
- Constant Speed Control automatically applies additional power to the motor
- Soft start suppresses start-up reaction for more control and longer tool life
- Electronic current limiter helps protect the motor from overload
- Anti-restart prevents accidental start up after power loss

Model PC5001C Includes: 5" Diamond Cup Wheel, Continuous Rim (A-94998), Hex Wrench (783203-8), Lock Nut Wrench (782425-7), Dust Bag (122853-8), Brush Set (194921-7), Steel Tool Case

Wheel Diameter	5"
No Load Speed	10,000 RPM
AMPS	10
Overall Length	18-13/16"
Net Weight	11.2 lbs.
Shipping Weight	26.5 lbs.



4101RH

5" MASONRY SAW
For Wet Cutting of Tile, Masonry, Concrete and More

- Powerful 7.9 AMP motor for the most demanding jobs
- Special cover design prevents water from entering into motor housing
- Cuts up to 1-5/8" at 90° and 1" at 45°
- Ground fault circuit interrupter (GFCI) plug
- Lock-on button for continuous operation
- Includes 15 ft. of tubing, water pressure regulator and water valve

Model 4101RH Includes: 5" Diamond Blade, Continuous Rim, Wet Cutting (A-90934), Hex Wrench (783203-8), Spanner Wrench (781011-1)

Blade Diameter	5"
Arbor	3/4"
Max Cutting Capacities:	at 90° (1-5/8"), at 45° (1")
No Load Speed	13,800 RPM
Watts Out	1,050
AMPS	7.9
Overall Length	9-1/4"
Net Weight	6.5 lbs.
Shipping Weight	9.3 lbs.



4100NH

4-3/8" MASONRY SAW
Powerful Cutting in Stone, Masonry, Tile & Concrete

- Powerful 12 AMP motor
- Cuts up to 1-3/8"
- Compact and lightweight at only 6.5 lbs.
- High power to weight ratio; 14,500 RPM
- Lock-off button helps prevent accidental starts
- Flat rear side of motor housing allows for easy blade changes

Model 4100NH Includes: Socket Wrench (782209-3), Spanner Wrench (781011-1), 4" Diamond Blade, Turbo, General Purpose (A-94546)

Blade Diameter	4-3/8"
Arbor	3/4"
Max Cutting Capacity	at 90° (1-3/8")
No Load Speed	14,500 RPM
Watts Out	1,500
AMPS	12
Overall Length	8-5/8"
Net Weight	6.5 lbs.
Shipping Weight	9.46 lbs.

Diamond Blades

Segmented Rim

Segment slots help deliver a faster cooler cut in multiple applications



Blade Diameter	Material	Part #
4"	Cured Concrete, Block, Brick	A-94677
5"	Cured Concrete, Block, Brick	A-94699

Turbo Rim

Constant contact with material delivers a smoother finish than segmented blades



Blade Diameter	Material	Part #
4"	Cured Concrete, Block, Brick	A-94546
4"	Granite, Ceramic, Fire Brick	A-94580
5"	Cured Concrete, Block, Brick	A-94568
5"	Granite, Ceramic, Fire Brick	A-94605

Continuous Rim



Blade Diameter	Material	Part #
5"	Cured Concrete, Block, Brick	A-90934

Additional Diamond Blades See pg. 105

DRILLS / FASTENING



4,000RPM

**4,000 RPM
Drywall Screwdriver**
FS4200



DRILLS



pgs. 50-51

**DRYWALL
SCREWDRIVERS**



pg. 52

SCREWDRIVERS



pgs. 52-53

IMPACTS



pgs. 53-54

ACCESSORIES



pgs. 96-98
106-107



GET REGISTERED

Register your products and keep them in one safe place, your own Tool Box. It is where you can go to obtain your tool model numbers and serial numbers in the event your tool is stolen or needs service.

[makitatools.com/
productregistration](http://makitatools.com/productregistration)



GET SERVICE

Go online to makitatools.com/service and download parts breakdowns and owners manuals for your tools.

[makitatools.com/
service](http://makitatools.com/service)

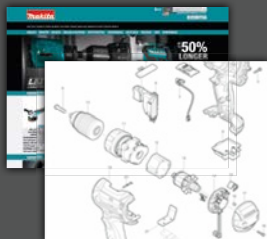

SERVICE CENTERS

Makita's Network of Service Centers ensure complete satisfaction on every product that we manufacture



Locate Nearest Service Center ONLINE:
makitatools.com/service

Free Technical Support:
1-800-4-MAKITA
(625482)



6407

3/8" DRILL Low Decibel Rating (79dB) for Quieter Operation

- Powerful 4.9 AMP motor for improved performance
- Variable speed (0 - 2,500 RPM) for drilling in a wide variety of materials
- In-line handle design for better control
- Reversing switch is conveniently located
- All ball bearing construction for longer tool life
- Large trigger switch for easy operation
- Large recessed lock-on button

Model 6407 Includes: 3/8" Drill Chuck (763136-3), Chuck Key (763423-0)

Capacities:	Steel (3/8"), Wood (1")
No Load Speed (variable speed)	0 - 2,500 RPM
AMPS	4.9
Overall Length	10-9/32"
Net Weight	3.1 lbs.
Shipping Weight	4 lbs.



6408
shown

6408 / 6408K

3/8" DRILL For Drilling in a Wide Variety of Materials

- Powerful 4.9 AMP motor
- Keyless chuck for fast and easy bit installation and removal
- Low decibel rating (79dB) for quieter operation
- Variable speed (0 - 2,500 RPM) for drilling in a wide variety of materials
- In-line handle design for improved performance
- Large trigger switch for easy operation

Model 6408 Includes: 3/8" Keyless Drill Chuck (763132-1)

Model 6408K Includes: Same as 6408 plus Tool Case

Capacities:	Steel (3/8"), Wood (1")
No Load Speed (variable speed)	0 - 2,500 RPM
AMPS	4.9
Overall Length	10-9/32"
Net Weight	3.1 lbs.
Shipping Weight	6408 (4 lbs.), 6408K (6.7 lbs.)



6302H

1/2" DRILL Industrial Metal Gear Housing for Durability

- Powerful 6.5 AMP motor for improved performance
- Variable speed (0 - 550 RPM) for drilling in a wide variety of materials
- Heavy duty industrial 1/2" drill chuck engineered for positive bit retention
- Compact and lightweight (4.8 lbs.)
- Side handle can be attached to either side of the tool
- Large and conveniently located lock-on button

Model 6302H Includes: Drill Chuck, 6302H, 6303H (763145-2), Chuck Key (763434-5), Side Handle (122593-8)

Capacities:	Steel (1/2"), Wood (1-3/8")
No Load Speed (variable speed)	0 - 550 RPM
AMPS	6.5
Overall Length	11-1/4"
Net Weight	4.8 lbs.
Shipping Weight	5.6 lbs.



DP4000 / DP4002

DP4000
shown

1/2" DRILL Lightweight Aluminum Gear Housing for Durability; 0-950 RPM

- Powerful 7.0 AMP motor for improved performance
- Variable speed for drilling in a wide variety of materials
- Retractable belt clip allows operation in tight areas
- Ergonomically designed rubberized grips for comfort
- Side handle rotates 360° for comfort and control
- All-ball and needle bearing construction for longer tool life

Models DP4000 & DP4002 Include: Drill Chuck (193229-6), Chuck Key (763430-3), Side Handle (134903-7)

Capacities:	Steel (1/2"), Wood (1-1/2")
No Load Speed (variable speed)	0 - 950 RPM
AMPS	7
Overall Length	12"
Net Weight	DP4000 (4.8 lbs.), DP4002 (4.9 lbs.)
Shipping Weight	DP4000 (6.4 lbs.), DP4002 (6.7 lbs.)

VARIABLE SPEED



SPEED

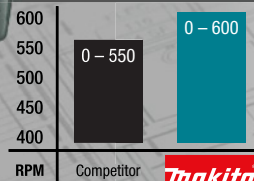

Variable speed (0 - 600 RPM) for mixing and drilling in a wide variety of materials

DS4012

1/2" SPADE HANDLE DRILL Powerful 8.5 AMP Motor with Variable Speed for Improved Mixing and Drilling Performance

- Variable speed (0 - 600 RPM) for mixing and drilling in a wide variety of materials
- Forward and reverse lever for operator convenience
- Well-balanced design at only 6.2 lbs. for reduced operator fatigue
- D-handle rotates 360° with 24 detent stops for multi-position operation

Model DS4012 Includes: Drill Chuck (193229-6), Chuck Key (763420-6), Side Handle (152492-0)

Capacities:	Steel (1/2"), Wood (1-1/2")
No Load Speed (variable speed)	0 - 600 RPM
AMPS	8.5
Overall Length	13-3/8"
Net Weight	6.2 lbs.
Shipping Weight	7.4 lbs.



DS4011

1/2" SPADE HANDLE DRILL
Powerful 8.5 AMP Motor with Variable Speed for Improved Mixing and Drilling Performance

- All-ball bearing construction for durability and longer tool life
- Heavy duty industrial 1/2" drill chuck engineered for positive bit retention
- Rocker switch for quick transition between forward and reverse operation
- On-board chuck key storage for fast and convenient bit changes
- 600 RPM provides increased speed and torque for drilling large holes

Model DS4011 Includes: Drill Chuck (193229-6), Chuck Key (763420-6), Side Handle (152492-0)

Capacities:	Steel (1/2"), Wood (1-1/2")
No Load Speed	600 RPM
AMPS	8.5
Overall Length	13-3/8"
Net Weight	6.3 lbs.
Shipping Weight	7.4 lbs.



DS4000

1/2" SPADE HANDLE DRILL
Faster 9.0 RPM and More Powerful 9.0 AMPS

- Durable all metal motor housing is jobsite tough yet lightweight
- Rocker switch for quick transition between forward and reverse operation
- Precision ground metal gears engineered to withstand the rigors of rotation changes
- 12" pipe handle with rubberized grip for greater control and improved ergonomics
- Powerful 9.0 AMP motor delivers 500 RPM and provides aggressive torque to match the job

Model DS4000 Includes: Drill Chuck (193319-5), Chuck Key (763434-5), Side Handle (152492-0)

Capacities:	Steel (1/2"), Wood (1-1/2")
No Load Speed	500 RPM
AMPS	9
Overall Length	14-1/4"
Net Weight	8.8 lbs.
Shipping Weight	13.2 lbs.



DA4000LR

1/2" ANGLE DRILL
360° Angle Attachment for Drilling in Any Position

- Powerful 7.5 AMP motor for improved performance
- 2-Speed (0 - 400 & 0 - 900 RPM) for increased drilling versatility
- Ergonomically designed rubberized grip for comfort
- All ball bearing construction for longer tool life
- Large multi-position side handle for operator comfort and control
- Angle attachment may be removed and drill used as a straight drill

Model DA4000LR Includes: Drill Chuck (193319-5), Chuck Key (763434-5), Side Handle (152892-4), Key Holder (410102-8), Hex Wrench 5 (783216-9), Drill Head Handle (122646-3), Tool Case

Capacities:	Steel (1/2"), Wood (1-1/2")
No Load Speed (2 spd)	400/900 RPM
AMPS	7.5
Overall Length	16-1/4"
Net Weight	8.1 lbs.
Shipping Weight	17.5 lbs.



DA3010F

3/8" ANGLE DRILL
Light Up Your Drilling Surface with L.E.D. Power

- Powerful 4 AMP motor for improved performance
- Variable speed (0 - 2,400 RPM) for drilling in a wide variety of materials
- Compact design (10-5/8" long and 2-5/8" head width) for use when working between framing studs and other close quarter applications
- Paddle switch with speed limiting dial to prevent over-tightening of fasteners
- Built-in clutch engineered to prevent gear damage by automatically disengaging gears if the bit binds

Model DA3010F Includes: Drill Chuck (763174-5), Chuck Key (763415-9), Key Holder (411780-7), Side Handle (153489-2)

Capacities:	Steel (3/8"), Wood (13/16")
No Load Speed (variable speed)	0 - 2,400 RPM
AMPS	4
Overall Length	10-5/8"
Net Weight	3.5 lbs.
Shipping Weight	4.21 lbs.



BRUSHLESS **XPT** **5.0Ah BATTERY**

XPH07TB

18v LXT® BRUSHLESS 1/2" HAMMER DRIVER-DRILL KIT
Delivers Up To 50% More Power and Performance¹

- BL™ Brushless Motor delivers 1,090 in.lbs. of Max Torque
- 0-31,500 BPM for fast hammer drilling in masonry materials
- Efficient BL™ Brushless motor is electronically controlled to optimize battery energy use for up to 50% longer run time per charge
- The BL™ Brushless Motor eliminates carbon brushes, enabling the BL™ Motor to run cooler and more efficiently for longer life

Model XPH07TB Includes: (2) 18V LXT® Lithium-Ion 5.0Ah Battery (BL1850B), 18V Lithium-Ion Rapid Optimum Charger (OC18RC), Side Handle (126413-8), Depth Gauge (122576-8), Belt Clip (346317-0), Tool Case

Model XPH07Z Includes: Tool only - battery and charger not included

Capacities:	Steel 1/2", Wood (3"), Masonry (5/8")
No Load Speed (var. 2 spd)	0 - 550 / 0 - 2,100 RPM
Blows Per Minute (2 speed)	0 - 8,250 / 0 - 31,500 BPM
Maximum Torque (in.lbs./N•m)	1,090 in.lbs./125N•m
Battery	18V LXT® Lithium-Ion
Overall Length	8-1/8"
Net Weight (with battery)	5.9 lbs.
Shipping Weight	16.12 lbs.

¹ Compared to LXP03



DA4031

1/2" ANGLE DRILL
Sidewinder® Handle Rotates 90° Left or Right

- Powerful 10 AMP motor for improved performance
- 2-Speed (300 & 1,200 RPM) for increased drilling versatility
- Built-in clutch reduces gear damage by disengaging gears if the bit binds (low speed only)
- Adjustable top handle with hex wrench storage
- Ergonomically designed rubberized grip for reduced operator fatigue
- Compact design for use when working between studs

Model DA4031 Includes: Drill Chuck (193319-5), Chuck Key (763434-5), Key Holder (410102-8), Wrench (783204-6), Side Handle (273654-8)

Capacities:	Steel (1/2"), Wood (1-1/2")
No Load Speed (2 spd)	300/1,200 RPM
AMPS	10
Overall Length	18-1/4"
Net Weight	12.3 lbs.
Shipping Weight	22.3 lbs.

DA6301

1/2" ANGLE DRILL
Ball and Needle Construction for Longer Tool Life

- Powerful 7.5 AMP motor for improved performance
- 2-Speed (300 & 1,200 RPM) for increased drilling versatility
- Triple gear reduction system engineered for maximum power
- Built-in clutch reduces gear damage by disengaging gears if the bit binds
- Rocker switch for quick transition between forward and reverse operation

Model DA6301 Includes: 1/2" Drill Chuck (763062-6), Chuck Key (763432-9), Side Handle (273476-6), Steel Tool Case

Capacities:	Steel (1/2"), Wood (1-1/2")
No Load Speed (2 spd)	300/1,200 RPM
AMPS	7.5
Overall Length	16-1/8"
Net Weight	9.5 lbs.
Shipping Weight	20 lbs.

Drill Accessories

Industrial Carbide-Tipped Hole Saws

- Lasts 15X longer and drills 2.6X faster than bi-metal hole saws
- Specially designed carbide tips for cutting clean holes
- Max. cutting depth of 1/8" with 2-1/2" overall length



Expandable Range of Applications

Type "C": Cobalt (Included)

- Stainless Steel
- Galvanized Iron
- Aluminum, etc.

Diameter	Part #	Center Bits Type C Part #
5/8"	714070-A	
3/4"	714071-A	
7/8"	714073-A	
1"	714074-A	
1-1/8"	714075-A	
1-1/4"	714077-A	
1-3/8"	714078-A	
1-1/2"	714079-A	714086-A
1-3/4"	714080-A	
2"	714081-A	
2-1/8"	714092-A	
2-1/4"	714082-A	
2-1/2"	714083-A	
3"	714085-A	

Additional Drill Accessories See pgs. 106-107



6,000RPM
FS6200 / FS6200TP

6,000 RPM DRYWALL SCREWDRIVER

Precision Balance With Less Weight

- Powerful 6.0 AMP motor with 0-6,000 RPM to handle the most challenging applications
- Less weight (only 3.0 lbs.) with precision balance for ultimate user comfort
- Built-in L.E.D. light illuminates the work area for greater productivity in low-light applications
- Steel-reinforced belt clip for user convenience and increased durability

Model FS6200 Includes: 3" Magnetic Bit Holder (784801-1), #2 Phillips Insert Bit, 1", 10/pk (784211-B)
Model FS6200TP features 50 ft. cord with Twist Lock

Bit Type	1/4" Hex
No Load Speed (variable speed)	0 - 6,000 RPM
AMPS	6
Overall Length	11-1/8"
Net Weight	3 lbs.
Shipping Weight	3.086 lbs.



4,000RPM
FS4200 / FS4200A / FS4200TP

4,000 RPM DRYWALL SCREWDRIVER

Precision Balance With Less Weight

- Powerful 6.0 AMP motor with 0-4,000 RPM to handle the most challenging applications
- Less weight (only 3.0 lbs.) with precision balance for ultimate user comfort
- Built-in L.E.D. light illuminates the work area for greater productivity in low-light applications
- Steel-reinforced belt clip for user convenience and increased durability

Model FS4200 Includes: 3" Magnetic Bit Holder (784801-1), #2 Phillips Insert Bit, 1", 10/pk (784211-B)
Model FS4200A features 50 ft. cord
Model FS4200TP features 50 ft. cord with Twist Lock

Bit Type	1/4" Hex
No Load Speed (variable speed)	0 - 4,000 RPM
AMPS	6
Overall Length	11-1/8"
Net Weight	3 lbs.
Shipping Weight:	FS4200 (4 lbs.), FS4200A (6.3 lbs.), FS4200TP (6.75 lbs.)



2,500RPM
FS2200

2,500 RPM DRYWALL SCREWDRIVER

Precision Balance With Less Weight

- Powerful 6.0 AMP motor with 0-2,500 RPM to handle the most challenging applications
- Less weight (only 3.5 lbs.) with precision balance for ultimate user comfort
- Built-in L.E.D. light illuminates the work area for greater productivity in low-light applications
- Steel-reinforced belt clip for user convenience and increased durability
- Adjustable depth locator assembly with Sure-Lock™ feature for consistent screw depth

Model FS2200 Includes: 3" Magnetic Bit Holder (784801-1), #2 Phillips Insert Bit, 1", 10/pk (784211-B)

Bit Type	1/4" Hex
No Load Speed (variable speed)	0 - 2,500 RPM
AMPS	6
Overall Length	11-1/8"
Net Weight	3.5 lbs.
Shipping Weight	3.306 lbs.



2,500RPM
FS2500

2,500 RPM SCREWDRIVER

Precision Balance With Less Weight

- Powerful 6.0 AMP motor with 0-2,500 RPM to handle the most challenging applications
- Less weight (only 3.4 lbs.) with precision balance for ultimate user comfort
- Built-in L.E.D. light illuminates the work area for greater productivity in low-light applications
- Steel-reinforced belt clip for user convenience and increased durability
- Adjustable depth locator assembly with Sure-Lock™ feature for consistent screw depth

Model FS2500 Includes: 5/16" Magnetic Nutsetter, 2-5/8" (784804-5)

Bit Type	1/4" Hex
No Load Speed (variable speed)	0 - 2,500 RPM
AMPS	6
Overall Length	11"
Net Weight	3.4 lbs.
Shipping Weight	3.306 lbs.

BL™ MOTOR DELIVERS 0-4,000 RPM



18v LXT® BRUSHLESS DRYWALL SCREWDRIVER KIT

Drives 1,860 Screws with Push Drive™ Technology using 4.0Ah BL1840B Battery!

- BL™ Motor delivers 0-4,000 RPM to handle a variety of drywall and framing applications
- Push Drive™ Technology – in lock-on mode the motor starts only when the fastener is engaged for a quieter work environment and to save battery power
- Ergonomically designed rubberized pistol grip with large 2-finger trigger for increased comfort
- Adjustable nose piece delivers consistent screw depth
- 3-stage L.E.D. gauge indicates battery charge level

*1-1/4" screw attaching 1/2" drywall to a 20 ga. steel stud

Model XSF03MB Includes: (2) 18V LXT® Lithium-Ion 4.0Ah Battery (BL1840B), 18V Lithium-Ion Rapid Optimum Charger (DC18RC), 3" Magnetic Bit Holder (784812-6), Tool Case

Model XSF03Z Includes: Tool Only; Battery and Charger not included

Bit Type	1/4" Hex
No Load Speed (variable speed)	0 - 4,000 RPM
Battery	18V LXT® Lithium-Ion
Overall Length	9-7/8"
Net Weight (with battery)	3.8 lbs.
Shipping Weight	13 lbs.



3706
Also Available: Dust Extracting Cut-Out Base 193449-2

DRYWALL CUT-OUT TOOL

Slim Body Design (2-1/4") for Comfort and Control

- Powerful 5 AMP motor for cutting into various material
- 32,000 RPM for faster cutting
- 2-way "Slide and Bump" on/off switch
- Sealed switch for extra protection from dust and debris and longer tool life
- "Tool-less" depth adjustment sets the desired cutting depth quickly and easily
- Slim body design (2-1/4" diameter) for comfort and control

Model 3706 Includes: Spanner Wrench (781008-0), 1/4" Collet (763608-8), 1/8" Collet (763660-6), 2-Pc 1/8" Drywall Guide Tip Bit (733229-0)

Collet Capacity	1/8", 1/4"
No Load Speed	32,000 RPM
AMPS	5
Overall Length	9-7/8"
Net Weight	2.4 lbs.
Shipping Weight	3.1 lbs.



XOC01MB

18v LXT® CUT-OUT TOOL KIT

Slim Body Design (2-1/4") for Comfort and Control

- Makita-built motor delivers 30,000 RPM for faster cutting
- Slide switch with lock-on for operator convenience
- On board bit change capabilities eliminates need for wrench
- Quick and easy "tool-less" depth adjustment
- Slim body design (2-1/4" diameter) for comfort and precision
- Large and conveniently located shaft lock button for fast bit changes

Model XOC01MB Includes: (2) 18V LXT® Lithium-Ion 4.0Ah Battery (BL1840B), 18V Lithium-Ion Rapid Optimum Charger (DC18RC), 1/8" Cut-Out Bit (193446-8), Spanner Wrench (781008-0), Tool Bag

Model XOC01Z Includes: Tool Only; Battery and Charger not included

Collet Capacity	1/8", 1/4"
No Load Speed	30,000 RPM
Battery	18V LXT® Lithium-Ion
Overall Length	12-3/8"
Net Weight (with battery)	3.7 lbs.
Shipping Weight	11 lbs.



2,500 RPM

FS2701

2,500 RPM SCREWDRIVER
6-Stage Torque Adjustment

- Powerful 6.0 AMP motor with 0-2,500 RPM to handle the most challenging applications
- Less weight (only 4.0 lbs.) with precision balance for ultimate user comfort
- Built-in L.E.D. light illuminates the work area for greater productivity in low-light applications
- Steel-reinforced belt clip for user convenience and increased durability
- Directional air-flow vents channel the tool's air output away from the user's face
- Large trigger with lock-on button located mid-handle for operator convenience

Model FS2701 Includes: 5/16" Magnetic Nutsetter, 2-5/8" (784804-5)

Bit Type	1/4" Hex
No Load Speed (variable speed)	0 - 2,500 RPM
AMPS	6
Overall Length	11-1/8"
Net Weight	4 lbs.
Shipping Weight	3.306 lbs.



Screws not included

6844

AUTOFEED SCREWDRIVER
"Tool-less" Screw Depth Adjustment

- High torque for driving screws up to 2-15/16" long
- Adjustable stopper base can be set for different screw lengths
- Ergonomic in-line D-handle design for driving control
- Silent clutch for reduced maintenance and quiet operation
- Belt clip for attaching to belt or holster
- "Tool-less" screw depth adjustment for easy depth settings

Model 6844 Includes: #2 Phillips Power Bit, 5/pk (B-10475), Tool Case

Bit Type	1/4" Hex
Collated Screw Capacity	1-3/4" - 2-15/16"
No Load Speed	3,000 RPM
AMPS	4.3
Overall Length	17-1/4"
Net Weight	4.5 lbs.
Shipping Weight	11.02 lbs.



2 YEAR TOOL WARRANTY
XRF02Z

NEW XRF02

3.0Ah BATTERY

18v LXT®
AUTOFEED SCREWDRIVER KIT
Ideal for Hanging Drywall

- Makita-built 4-pole motor delivers superior fastening speed with 4,000 RPM
- High collated screw capacity range: 1" to 2-1/8"
- Screw guide prevents screw strip tangling and can fold against the autofeed housing for easy storing
- Rugged aluminum dust-proof autofeed housing provides smooth sliding action

Model XRF02 Includes: (2) 18V LXT® Lithium-Ion 3.0Ah Battery (BL1830), 18V Lithium-Ion Rapid Optimum Charger (DC18RC), #2 Phillips Power Bit, 2/pk (B-10481), Square Power Bit, 1/pk (784645-9), Tool Bag

Model XRF02Z Includes: Tool Only; Battery and Charger not included

Bit Type	1/4" Hex
Collated Screw Capacity	1" - 2-3/16"
No Load Speed	4,000 RPM
Battery	18V LXT® Lithium-Ion
Overall Length	16-3/4"
Net Weight (with battery)	5.1 lbs.
Shipping Weight	13.4 lbs.

Screwdriver Accessories

Nose Cone

Model	Part #
FS2200, FS4200/A/TP, FS6200/TP, LXSFO1	195542-8

Nose Cone

Model	Part #
6825, 6823N, 68245N/NA	151726-8
6821, 6826	152483-1
XDT01, XDT08, XDT04, XDT09	194633-2
FS2200, FS4200/A/TP, FS6200/TP, XSF03	158876-0

Locator

Size	Model	Part #
1/4"	6826N	152821-7
5/16"	6826	152822-5
5/16"	FS2500	450967-6
3/8"	6826	152823-3
For Power Bits	6827	322120-3

Power Cords

Length	Model	Part #
8.4'	FS2200, FS2500, FS4200, FS6200	664064-4
50'	FS4200TP, FS6200TP	699037-8
50'	FS4200A	660066-8-50



6952

1/4" IMPACT DRIVER
Fast 0-3,200 RPM and High Torque of 88.5 ft.lbs.

- Variable speed trigger (0 - 3,200 RPM) for easy operation
- Impact resistant aluminum housing for gear protection and durability
- Compact and lightweight (3.1 lbs.) for both vertical and horizontal applications
- Rubberized pistol grip provides increased comfort on the job
- Dual ball bearings for longer tool life
- 2.3 AMP motor for high performance (0-3,100 IPM)

Model 6952 Includes: Belt Clip (324284-9), Tool Case

Capacity:	Hex Drive (1/4")
Impacts Per Minute (variable speed)	0 - 3,100 IPM
No Load Speed (variable speed)	0 - 3,200 RPM
Maximum Torque (ft.lbs./N•m)	120 ft.lbs./162 N•m
AMPS	2.3
Overall Length	9"
Net Weight	3.1 lbs.
Shipping Weight	6.6 lbs.



6953

1/2" IMPACT WRENCH
W/ DETENT PIN ANVIL
0 - 3,000 RPM and Max Torque of 110 ft.lbs.

- All metal hammer casing to withstand all environments
- Externally accessible brushes for easy replacement
- 0 - 3,000 impacts per minute for maximum efficiency
- Compact length for easier handling and operator control
- Convenient belt clip attaches to both sides of the tool
- Ideal for garage door installers, metal framers and deck builders

Model 6953 Includes: Belt Clip (324284-9), Tool Case

Capacity:	Square Drive (1/2")
Impacts Per Minute (variable speed)	0 - 3,000 IPM
No Load Speed (variable speed)	0 - 3,000 RPM
Maximum Torque (ft.lbs./N•m)	110 ft.lbs./150 N•m
AMPS	2.5
Overall Length	9-1/8"
Net Weight	3.3 lbs.
Shipping Weight	6.6 lbs.



TW0200

1/2" IMPACT WRENCH
W/ DETENT PIN ANVIL
Max Torque of 150 ft.lbs.

- Variable speed 0 - 2,200 RPM for controlled fastening
- Efficient impact system with less vibration
- Externally accessible brushes for easy replacement
- Precision gearing with ball and needle bearing construction for smooth and efficient power transmission
- Compact and lightweight (4.9 lbs.) for use in close quarters
- Impact-resistant aluminum gear case with rubber boot for increased durability

Model TW0200 Includes: Belt Clip (324284-9), Tool Case

Capacity:	Square Drive (1/2")
Impacts Per Minute (variable speed)	0 - 2,200 IPM
No Load Speed (variable speed)	0 - 2,200 RPM
Maximum Torque (ft.lbs./N•m)	150 ft.lbs./200 N•m
AMPS	3.3
Overall Length	9-7/8"
Net Weight	4.9 lbs.
Shipping Weight	8.8 lbs.

Drywall Cut-Out Tool
Accessories

Industrial Cut-Out Bits

Description	Size	Qty./Pkg.	Model	Part #
Drywall/ Guide Tip	1/8"	10	3706, XOC01	193452-3
Window/ Door	1/4"	1		193453-1

Circular Guide

Description	Model	Part #
Cleaner, more precise circle/arc cuts up to 14" in diameter	3706, XOC01	193454-9

Collet Cone and Adaptor

Description	Size	Model	Part #
Collet Cone	1/4"		763608-8
Collet Cone	1/8"	3706	763660-6
Collet Cone	1/4"	XOC01	763676-1
Collet Cone	1/8"		763677-9

Autofeed Screwdriver
Accessories

Autofeed Screwdriver
30" Extension Handle

Model	Part #
6834	192501-3
6844, BFR750, XRF01	194500-1



TW0350

1/2" IMPACT WRENCH W/ DETENT PIN ANVIL

Max Torque of 258 ft.lbs.

- Powerful 3.5 AMP motor delivers 2,000 RPM/IPM for heavy duty applications
- Efficient impact system with less vibration
- Externally accessible brushes for easy replacement
- Precision gearing with ball and needle bearing construction for efficient power transmission
- Compact and lightweight (6.6 lbs.) for use in close quarters
- Impact resistant aluminum gear housing with rubber boot for increased durability

Model TW0350 Includes: Belt Clip (324284-9), Tool Case

6906

3/4" IMPACT WRENCH W/ FRICTION RING ANVIL

Max Torque of 433 ft.lbs.

- Powerful 9.0 AMP motor delivers 1,700 RPM for heavy duty applications
- Precision gearing with ball and needle bearing construction for smooth and efficient power transmission
- Rocker switch with forward/reverse operation for user convenience
- Side handle rotates 360° for operator convenience
- Externally accessible brushes for easy replacement

Model 6906 Includes: Side Handle (122464-9), Steel Tool Case

TW1000

1" IMPACT WRENCH W/ FRICTION RING ANVIL

Large Hammer for Greater Impact Power

- Max torque of 738 ft.lbs.
- Efficient impact system with less vibration
- Externally accessible brushes for easy replacement, and ball bearings for longer tool life
- Side handle rotates 360° for operator convenience
- Impact resistant aluminum gear housing with rubber boot for protection and increased durability
- Rocker switch with forward/reverse operation for user convenience

Model TW1000 Includes: Side Handle (123018-5), Tool Case

6922NB

3/4" SHEAR WRENCH

Compact and Lightweight Yet Powerful

- Delivers 593 ft.lbs. of max torque for the most demanding applications
- Anti-slipping mechanism: tool won't start until inner sleeve engages with bolt tip
- Bolt tip ejecting lever located by power trigger for increased convenience
- Light weight design at only 10.6 lbs.

Model 6922NB Includes: Outer Sleeve, 3/4" - M20 (764361-9), Outer Sleeve, 7/8" - M22 (153909-6), Screwdriver (783001-0), Inner Sleeve, 7/8" - M22 (764418-6), Steel Tool Case

Capacity:	Square Drive (1/2")
Impacts Per Minute	2,000 IPM
No Load Speed (variable speed)	0 - 2,000 RPM
Maximum Torque (ft.lbs./N•m)	258 ft.lbs./350 N•m
AMPS	3.5
Overall Length	11-1/8"
Net Weight	6.6 lbs.
Shipping Weight	11 lbs.

Capacity:	Square Drive (3/4")
Impacts Per Minute	1,600 IPM
No Load Speed	1,700 RPM
Maximum Torque (ft.lbs./N•m)	433 ft.lbs./588 N•m
AMPS	9
Overall Length	12-7/8"
Net Weight	12.3 lbs.
Shipping Weight	22 lbs.

Capacity:	Square Drive (1")
Impacts Per Minute	1,500 IPM
No Load Speed	1,400 RPM
Maximum Torque (ft.lbs./N•m)	738 ft.lbs./1,000 N•m
AMPS	12
Overall Length	15"
Net Weight	19 lbs.
Shipping Weight	19.8 lbs.

Capacity:	Bolt Drive (5/8", 3/4", 7/8")
No Load Speed	18 RPM
Maximum Torque (ft.lbs./N•m)	593 ft.lbs./804 N•m
Overall Length	9-13/16"
Net Weight	10.6 lbs.
Shipping Weight	20.12 lbs.



Z
ZERO VIBRATION

XWT08Z



Z
ZERO VIBRATION

XWT07Z



Z
ZERO VIBRATION

XWT09Z



Z
ZERO VIBRATION

XWT02Z

LXT
BRUSHLESS

NEW XWT08M

4.0 BATTERY

18v LXT® BRUSHLESS HIGH TORQUE 1/2" IMPACT WRENCH KIT

Perfect for High Torque Fastening Applications

- BL™ Motor delivers 740 ft.lbs. of Max Torque and 1,180 ft.lbs of breakaway torque
- 3-speed (0-900/0-1,000/0-1,800 RPM & 0-1,800/0-2,000/0-2,200 IPM) for precise fastening control
- Compact and ergonomic design at only 9" long
- 1/2" anvil with friction ring for quick and easy socket changes

Model XWT08M Includes: (2) 18V LXT® Lithium-Ion 4.0Ah Battery (BL1840B), 18V Lithium-Ion Rapid Optimum Charger (DC18RC), Tool Bag

Model XWT08Z Includes: Tool Only, Battery and Charger not included

Square Drive	1/2"
No Load Speed (3 speed)	0 - 900 / 0 - 1,000 / 0 - 1,800 RPM
Impacts Per Minute (3 speed)	0 - 1,800 / 0 - 2,000 / 0 - 2,200 IPM
Maximum Torque (ft.lbs.)	740 ft.lbs.
Battery	18V LXT® Lithium-Ion
Overall Length	9"
Net Weight (with battery)	7.9 lbs.
Shipping Weight	16.2 lbs.

LXT
BRUSHLESS

NEW XWT07M

4.0 BATTERY

18v LXT® BRUSHLESS HIGH TORQUE 3/4" IMPACT WRENCH KIT

Perfect for High Torque Fastening Applications

- BL™ Motor delivers 780 ft.lbs. of Max Torque and 1,250 ft.lbs of breakaway torque
- 3-speed power selection switch (0-900/0-1,000/0-1,800 RPM & 0-1,800/0-2,000/0-2,200 IPM) provides precise fastening control
- 3/4" anvil with friction ring and thru hole retention system for maximum productivity

Model XWT07M Includes: (2) 18V LXT® Lithium-Ion 4.0Ah Battery (BL1840B), 18V Lithium-Ion Rapid Optimum Charger (DC18RC), Tool Bag

Model XWT07Z Includes: Tool Only, Battery and Charger not included

Square Drive	3/4"
No Load Speed (3 speed)	0 - 900 / 0 - 1,000 / 0 - 1,800 RPM
Impacts Per Minute (3 speed)	0 - 1,800 / 0 - 2,000 / 0 - 2,200 IPM
Maximum Torque (ft.lbs.)	780 ft.lbs.
Battery	18V LXT® Lithium-Ion
Overall Length	9"
Net Weight (with battery)	8.1 lbs.
Shipping Weight	16.6 lbs.

LXT
BRUSHLESS

NEW XWT09T

5.0 BATTERY

18v LXT® BRUSHLESS HIGH TORQUE 7/16" HEX IMPACT DRILL KIT

Perfect for High Torque Drilling Applications

- BL™ Motor delivers 590 ft.lbs. of Max Torque
- 3-speed power selection switch (0-900/0-1,000/0-1,800 RPM & 0-1,800/0-2,000/0-2,200 IPM) provides the user with precise fastening control
- The BL™ Brushless Motor eliminates carbon brushes, enabling the BL Motor to run cooler and more efficiently for longer life
- Efficient BL™ Brushless motor is electronically controlled to optimize battery energy use for up to 50% longer run time per charge

Model XWT09T Includes: 18V LXT® Lithium-Ion 5.0Ah Battery (BL1850B), 18V Lithium-Ion Rapid Optimum Charger (DC18RC), Tool Bag

Model XWT09Z Includes: Tool Only, Battery and Charger not included

Hex Shank	7/16"
No Load Speed (3 speed)	0 - 900 / 0 - 1,000 / 0 - 1,800 RPM
Impacts Per Minute (3 speed)	0 - 1,800 / 0 - 2,000 / 0 - 2,200 IPM
Maximum Torque (ft.lbs.)	590 ft.lbs.
Battery	18V LXT® Lithium-Ion
Overall Length	9"
Net Weight (with battery)	8.1 lbs.
Shipping Weight	16.7 lbs.

LXT
BRUSHLESS

NEW XWT02MB

4.0 BATTERY

18v LXT® BRUSHLESS 3-SPEED 1/2" IMPACT WRENCH KIT

Improved Fastening Control

- BL™ Brushless Motor delivers 210 ft.lbs. of Max Torque
- Compact and ergonomic design at only 5-3/4" long
- 3-speed power selection switch (0-1,600/0-2,100/0-2,800 RPM & 0-1,800/0-2,600/0-3,500 IPM) for precise fastening control
- Efficient BL™ Brushless Motor is electronically controlled to optimize battery energy use for up to 50% longer run time per charge

Model XWT02MB Includes: (2) 18V LXT® Lithium-Ion 4.0Ah Battery (BL1840B), 18V Lithium-Ion Rapid Optimum Charger (DC18RC), Tool Bag

Model XWT02Z Includes: Tool Only, Battery and Charger not included

Square Drive	1/2"
No Load Speed (3 speed)	0 - 1,600 / 0 - 2,100 / 0 - 2,800 RPM
Impacts Per Minute (3 speed)	0 - 1,800 / 0 - 2,600 / 0 - 3,500 IPM
Maximum Torque (ft.lbs./N•m)	210 ft.lbs./280 N•m
Battery	18V LXT® Lithium-Ion
Overall Length	5-3/4"
Net Weight (with battery)	3.8 lbs.
Shipping Weight	12 lbs.

METALWORKING

SJST

**5" SJS™II
Angle Grinder
GA5042C**

SJST

**4-1/2" SJS™II
Angle Grinder
GA4542C**

**ANGLE
GRINDERS**



pgs. 56-60

**DIE
GRINDERS**



pg. 60-61

**SANDERS /
POLISHERS**



pg. 62

**NIBBLERS /
SHEARS**



pg. 63

SAWS



pg. 64

ACCESSORIES



pgs. 108 - 115



GA4030 / GA4030K

4" ANGLE GRINDER

Small Diameter Barrel Grip (Only 2-1/4")

- Powerful 6.0 AMP motor delivers 11,000 RPM
- Compact design at only 3.7 lbs.
- Labyrinth construction seals and protects motor and bearings
- Slide switch design with lock-on
- Ideal for welders, fabricators, masons, maintenance/repair and more

Model GA4030 Includes: 4"X3/16" Grinding Wheel, Bulk (741402-B), 4" Wheel Guard (125885-4), Lock Nut (194608-1), Lock Nut Wrench (782420-7), Side Handle (153504-2), Inner Flange (224377-1)

Model GA4030K Includes: Same as GA4030 plus Tool Case

GA4530

4-1/2" ANGLE GRINDER

Small Diameter Barrel Grip (Only 2-1/4")

- Powerful 6.0 AMP motor delivers 11,000 RPM
- Compact design at only 4.0 lbs.
- Labyrinth construction seals and protects motor and bearings
- Slide switch design with lock-on

Model GA4530 Includes: 4-1/2" Grinding Wheel (A-95956), 4-1/2" Wheel Guard (122886-3), Lock Nut (194608-1), Lock Nut Wrench (782420-7), Inner Flange (224377-1), Side Handle (153504-2)

GA4534

AC/DC

4-1/2" PADDLE SWITCH ANGLE GRINDER

Small Diameter Barrel Grip (Only 2-1/4")

- Powerful 6.0 AMP motor delivers 11,000 RPM
- Compact design at only 4.2 lbs.
- Labyrinth construction seals and protects motor and bearings
- Paddle switch with no lock-on
- AC/DC switch for use with alternative power sources

Model GA4534 Includes: 4 1/2" Grinding Wheel (741423-B), 4-1/2" Wheel Guard (122886-3), Lock Nut Wrench (782424-9), Side Handle (153504-2), Inner Flange (224399-1), Lock Nut (224568-4)

9557NB

AC/DC

4-1/2" ANGLE GRINDER

AC/DC Switch for Use with Alternative Power Source

- Powerful 7.5 AMP motor delivers 11,000 RPM for high output power
- Compact design with small 2-1/2" diameter barrel and weighs only 4.5 lbs. for added comfort
- Protective zig-zig varnish seals the armature from dust and debris for longer tool life
- Labyrinth construction seals and protects the drive gear and bearings from contamination
- AC/DC slide switch for use with alternative power source

Model 9557NB Includes: 4-1/2" Grinding Wheel (A-95956), 4-1/2" Wheel Guard (125273-5), Lock Nut (193465-4), Lock Nut Wrench (782422-3), Inner Flange (224399-1), Side Handle (153489-2)

Wheel Diameter	4"
AMPS	6
No Load Speed	11,000 RPM
Spindle Thread	M10 x 1.25
Lock-On: (Yes)	Lock-Off: (No)
Grinder Switch Type	Body grip/slide
Overall Length	10-1/2"
Net Weight	3.7 lbs.
Shipping Weight	GA4030 (6.28 lbs.), GA4030K (8.1 lbs.)

Wheel Diameter	4-1/2"
AMPS	6
No Load Speed	11,000 RPM
Spindle Thread	5/8" - 11 UNC
Lock-On: (Yes)	Lock-Off: (No)
Grinder Switch Type	Body grip/slide
Overall Length	10-1/2"
Net Weight	4 lbs.
Shipping Weight	6.28 lbs.

Wheel Diameter	4-1/2"
AMPS	6
No Load Speed	11,000 RPM
Spindle Thread	5/8" - 11 UNC
Lock-On: (No)	Lock-Off: (Yes)
Grinder Switch Type	Body grip/paddle
Overall Length	10-3/8"
Net Weight	4.2 lbs.
Shipping Weight	6.05 lbs.

Wheel Diameter	4-1/2"
AMPS	7.5
No Load Speed	10,000 RPM
Spindle Thread	5/8" - 11 UNC
Lock-On: (Yes)	Lock-Off: (No)
Grinder Switch Type	Body grip/slide
Overall Length	10-5/8"
Net Weight	4.5 lbs.
Shipping Weight	6.28 lbs.



9557PB

AC/DC

4-1/2" PADDLE SWITCH ANGLE GRINDER

Large Flush-Mount Paddle Switch for Comfortable Operation

- Powerful 7.5 AMP motor delivers 11,000 RPM for high output power
- Compact design with small 2-1/2" diameter barrel and weighs only 4.5 lbs. for added comfort
- Protective zig-zig varnish seals the armature from dust and debris for longer tool life
- Labyrinth construction seals and protects the drive gear and bearings from contamination

Model 9557PB Includes: 4-1/2" Grinding Wheel (A-95956), 4-1/2" Wheel Guard (125273-5), Lock Nut (193465-4), Lock Nut Wrench (782422-3), Side Handle (153489-2), Inner Flange (224399-1)

Wheel Diameter	4-1/2"
AMPS	7.5
No Load Speed	11,000 RPM
Spindle Thread	5/8" - 11 UNC
Lock-On: (Yes)	Lock-Off: (Yes)
Grinder Switch Type	Body grip/paddle
Overall Length	10-3/4"
Net Weight	4.5 lbs.
Shipping Weight	6.39 lbs.

INNOVATION

SJS® - SUPER JOINT SYSTEM

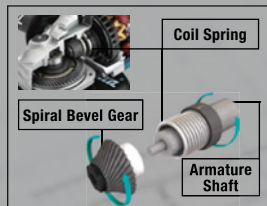

The drive shaft from the armature to the drive gear is spring loaded.

If the wheel is forced to stop, the spring is compressed allowing the drive shaft to slip.

DURABILITY

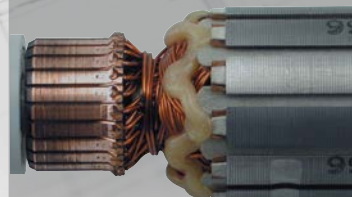

Protective zig-zag varnish protects the armature coil by deflecting dust & debris

POWERFUL & EFFICIENT



COMFORT

Large paddle switch with lock-off and no lock-on feature



9564P

4-1/2" SJS™ PADDLE SWITCH ANGLE GRINDER

SJS™ Mechanical Clutch System Helps Prevent Motor and Gear Damage

- Powerful 10.0 AMP motor delivers more output and 10,500 RPM
- SJS™ technology is a mechanical clutch system that helps prevent motor and gear damage by allowing the drive shaft to slip
- Larger cooling fan and blades pull more air through the motor to help maintain lower operating temperature
- Large flush-mount paddle switch
- Labyrinth construction prevents debris from penetrating the motor, bearings and gears for longer tool life

Model 9564P Includes: Side Handle (153489-2), 4-1/2" Tool-less Wheel Guard (135107-4), Inner Flange (224399-1), Lock Nut (193465-4), Lock Nut Wrench (782424-9)

Wheel Diameter	4-1/2"
AMPS	10
No Load Speed	10,500 RPM
Spindle Thread	5/8" - 11 UNC
Lock-On: (No)	Lock-Off: (Yes)
Overall Length	12-1/8"
Grinder Switch Type	Body grip/paddle
Net Weight	5.1 lbs.
Shipping Weight	6.5 lbs.



18v LXT® BRUSHLESS 4-1/2" CUT-OFF/ANGLE GRINDER KIT

Electric Brake and Large Flush-Mount Paddle Switch

- Electric brake for maximum productivity
- Electronic RPM controller turns the motor off if rotation speed suddenly slows or wheel is forced to stop
- Automatic Speed Change™ technology adjusts speed and torque during operation for optimum performance

Model XAG10M Includes: (2) 18V LXT® Lithium-Ion 4.0Ah Battery (BL1840B), 18V Lithium-Ion Rapid Optimum Charger (DC18RC), 4-1/2" Grinding Wheel (A-95956), 4-1/2" Cut-off Wheel (724115-A), 4-1/2" Wheel Guard (123144-0), 4-1/2" Cut-Off Wheel Guard (122910-2), Tool Case, Side Handle

Model XAG10Z Includes: Tool Only; Battery and Charger not included

Grinding Wheel	4-1/2"
No Load Speed	8,500 RPM
Spindle Thread	5/8" - 11 UNC
Lock-On: No	Lock-Off: Yes
Grinder Switch Type	Body grip/paddle
Battery	18V LXT® Lithium-Ion
Overall Length	14-1/4"
Net Weight (with battery)	5.6 lbs.
Shipping Weight	19.1 lbs.



18v LXT® BRUSHLESS 4-1/2" CUT-OFF/ANGLE GRINDER

Large Flush-Mount Paddle Switch for Comfortable Operation

- Automatic Speed Change™ technology adjusts speed and torque during operation for optimum performance
- Electronic RPM controller turns the motor off if rotation speed suddenly slows or wheel is forced to stop
- The BL™ Brushless Motor eliminates carbon brushes, enabling the BL™ Motor to run cooler and more efficiently for longer life; delivers 8,500 RPM

Model XAG06MB Includes: (2) 18V LXT® Lithium-Ion 4.0Ah Battery (BL1840B), 18V Lithium-Ion Rapid Optimum Charger (DC18RC), 4-1/2" Grinding Wheel (A-95956), 4-1/2" Cut-off Wheel (724115-A), 4-1/2" Wheel Guard (123144-0), 4-1/2" Cut-Off Wheel Guard (122910-2), Side Handle, Tool Case

Model XAG06Z Includes: Tool Only; Battery and Charger not included

Grinding Wheel	4-1/2"
No Load Speed	8,500 RPM
Spindle Thread	5/8" - 11 UNC
Lock-On: No	Lock-Off: Yes
Grinder Switch Type	Body grip/paddle
Battery	18V LXT® Lithium-Ion
Overall Length	14-1/4"
Net Weight (with battery)	5.6 lbs.
Shipping Weight	19.1 lbs.



18v LXT® BRUSHLESS 4-1/2" CUT-OFF/ANGLE GRINDER KIT

Slide Switch For User Convenience

- BL™ Brushless motor delivers 8,500 RPM
- Automatic Speed Change™ technology adjusts speed and torque during operation for optimum performance
- The BL™ Brushless Motor eliminates carbon brushes, enabling the BL™ Motor to run cooler and more efficiently for longer life

Model XAG03MB Includes: (2) 18V LXT® Lithium-Ion 4.0Ah Battery (BL1840B), 18V Lithium-Ion Rapid Optimum Charger (DC18RC), 4-1/2" Grinding Wheel (A-95956), 4-1/2" Cut-off Wheel (724115-A), 4-1/2" Wheel Guard (123144-0), 4-1/2" Cut-Off Wheel Guard (122910-2), Side Handle, Tool Case

Model XAG03Z Includes: Tool Only; Battery and Charger not included

Grinding Wheel	4-1/2"
No Load Speed	8,500 RPM
Spindle Thread	5/8" - 11 UNC
Lock-On: Yes	Lock-Off: No
Grinder Switch Type	Body grip/slide
Battery	18V LXT® Lithium-Ion
Overall Length	14-1/4"
Net Weight (with battery)	5.5 lbs.
Shipping Weight	19 lbs.



5" PADDLE SWITCH ANGLE GRINDER

Large Flush-Mount Paddle Switch for Comfortable Operation

- Powerful 7.5 AMP motor for heavy professional grinding applications
- Small diameter barrel grip for added comfort
- Labyrinth construction seals and protects motor and bearings from contamination
- AC/DC Switch for use with alternative power source
- Protective zig-zig varnish seals the armature from dust and debris for longer tool life

Model 9558PB Includes: 5" x 1/4" x 7/8" INOX Grinding Wheel, 36 Grit (A-95962), 5" Wheel Guard (125274-3), Lock Nut (193465-4), Lock Nut Wrench (782422-3), Side Handle (153489-2), Inner Flange (224399-1)

Wheel Diameter	5"
AMPS	7.5
No Load Speed	10,000 RPM
Spindle Thread	5/8" - 11 UNC
Lock-On: No	Lock-Off: Yes
Grinder Switch Type	Body grip/paddle
Overall Length	10-3/4"
Net Weight	4.6 lbs.
Shipping Weight	6.62 lbs.



9565PCV

13 AMP

5" SJS™ HIGH-POWER PADDLE SWITCH ANGLE GRINDER

Paddle Switch and Variable Speed Dial for Operator Convenience

- Powerful 13.0 AMP motor delivers more output and variable (2,800 - 10,500) RPM for the most demanding applications
- SJS™ technology is a mechanical clutch system that minimizes motor and gear damage by allowing the drive shaft to slip if the wheel is forced to stop
- Variable speed control dial enables user to match the speed to the application

Model 9565PCV Includes: 5" x 1/4" x 7/8" INOX Grinding Wheel, 36 Grit (A-95962), Side Handle (153489-2), 5" Tool-less Wheel Guard (135108-2), Inner Flange (224399-1), Lock Nut (193465-4), Lock Nut Wrench (782424-9)

Wheel Diameter	5"
AMPS	13
No Load Speed	10,500 RPM
Spindle Thread	5/8" - 11 UNC
Lock-On: No	Lock-Off: Yes
Grinder Switch Type	Body grip/paddle
Overall Length	12-1/8"
Net Weight	4.2 lbs.
Shipping Weight	7.3 lbs.



9565PC / 9564PC (4 1/2")

13 AMP

5" SJS™ PADDLE SWITCH ANGLE GRINDER

SJS™ Mechanical Clutch System Helps Prevent Motor and Gear Damage

- Powerful 13.0 AMP motor delivers more output and 10,500 RPM
- Constant speed control automatically applies additional power to the motor to maintain speed under load
- Electronic current limiter helps protect the motor from overload. Large no lock-on paddle switch with lock-off for comfortable operation

Model 9565PC Includes: 5" x 1/4" x 7/8" INOX Grinding Wheel, 36 Grit (A-95962), Side Handle (153489-2), 5" Tool-less Wheel Guard (135108-2), Inner Flange (224399-1), Lock Nut (193465-4), Lock Nut Wrench (782424-9)

Model 9564PC Includes: Same as 9565PC except 4-1/2" x 1/4" x 7/8" INOX Grinding Wheel, 36 Grit (A-95956) and 4-1/2" Tool-less Wheel Guard (135107-4)

Wheel Diameter	9565PC (5"), 9564PC (4-1/2")
AMPS	13
No Load Speed	10,500 RPM
Spindle Thread	5/8" - 11 UNC
Lock-On: (No)	Lock-Off: (Yes)
Grinder Switch Type	Body grip/paddle
Overall Length	12-1/8"
Net Weight	9565PC (5.3 lbs.), 9564PC (5.3 lbs.)
Shipping Weight	9565PC (7.2 lbs.), 9564PC (7.2 lbs.)



9565CV / 9564CV (4 1/2")

12 AMP

5" SJS™ ANGLE GRINDER

Electronic Controller for Increased Durability

- Powerful 12.0 AMP Motor Delivers More Output and 10,500 RPM
- Variable speed control dial enables user to match the speed to the application
- Constant speed control automatically applies additional power to the motor to maintain speed under load
- Soft start suppresses start-up reaction for smooth start-ups and longer gear life

Model 9565CV Includes: 5" x 1/4" x 7/8" INOX Grinding Wheel, 36 Grit (A-95962), Lock Nut Wrench (782412-6), Side Handle (153489-2), Lock Nut (193465-4), Inner Flange (224378-9), 5" Tool-less Wheel Guard (135108-2)

Model 9564CV Includes: Same as 9565CV except 4-1/2" x 1/4" x 7/8" INOX Grinding Wheel, 36 Grit (A-95956) and 4-1/2" Tool-less Wheel Guard (135107-4)

Wheel Diameter	9565CV (5"), 9564CV (4-1/2")
AMPS	12
No Load Speed (variable speed)	2,800 - 10,500 RPM
Spindle Thread	5/8" - 11 UNC
Lock-On: Yes	Lock-Off: No
Grinder Switch Type	Body grip/slide
Overall Length	11-3/4"
Net Weight	9565CV (5.2 lbs.), 9564CV (5.3 lbs.)
Shipping Weight	9565CV (7.4 lbs.), 9564CV (7.3 lbs.)



9005B / 9005BZ

9 AMP

5" ANGLE GRINDER

Job Site Proven for Over 20 Years

- Lightweight (6.6 lbs.) for high production work with less fatigue
- 9.0 AMP motor for powerful performance
- Side handle can be installed on either side of the tool for operator convenience
- Spindle lock for easy wheel changes
- Lock-on feature for continuous operation
- Alternate model 9005BZ features a no lock-on function

Model 9005B / 9005BZ Includes: 5" x 1/4" x 7/8" INOX Grinding Wheel, 36 Grit (A-95962), 5" Wheel Guard (135549-2), Side Handle (152492-0), Inner Flange (224378-9), Lock Nut (193465-4), Lock Nut Wrench (782412-6), Spindle Washer (261039-0)

Wheel Diameter	5"
AMPS	9
No Load Speed	10,000 RPM
Spindle Thread	5/8" - 11 UNC
Lock-On: Yes	Lock-Off: No
Grinder Switch Type	Rear trigger switch
Overall Length	14"
Net Weight	6.6 lbs.
Shipping Weight	9.3 lbs.

SJS II™

Two component system helps to reduce vibration

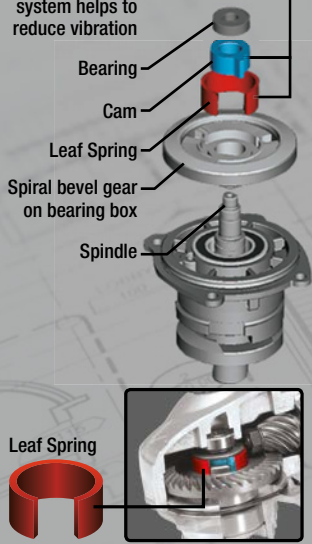

SJS™ II provides a leaf spring and cam gear drive mechanism engineered to reduce vibration for increased operator comfort during extended use. Includes vibration absorbing side handle which provides increased comfort on the job.

SJS II GA5042C / GA4542C (4½") HIGH POWER 12

5" SJS™ II ANGLE GRINDER SJS™ II Technology Reduces Vibration for User Comfort

- Powerful 12.0 AMP motor delivers more output and variable (2,800 - 11,000) RPM
- SJS™ II provides a leaf spring and cam gear drive mechanism that is engineered to reduce vibration for increased operator comfort during extended use
- Variable speed control dial enables user to match the speed to the application

Model GA5042C Includes: Inner Flange (224399-1), Lock Nut Wrench (782412-6), 5" x 1/4" x 7/8" INOX Grinding Wheel, 36 Grit (A-95962), 5" Tool-less Wheel Guard (123145-8), Side Handle (162258-0), Lock Nut (224568-4)

Model GA4542C Includes: Same as GA5042C except 4-1/2" x 1/4" x 7/8" Inox Grinding Wheel, 36 Grit (A-95956) and 4-1/2" Tool-Less Wheel Guard (123144-0)

Wheel Diameter	GA5042C (5"), GA4542C (4-1/2")
AMPS	12
No Load Speed (variable speed)	2,800 - 11,000 RPM
Spindle Thread	5/8" - 11 UNC
Lock-On: Yes	Lock-Off: No
Grinder Switch Type	Body grip/slide
Overall Length	11-7/8"
Net Weight	5.4 lbs.
Shipping Weight	8 lbs.

SJS II GA5040X1 HIGH POWER 12

5" SJS™ II ANGLE GRINDER WITH TUCK POINT GUARD 5" Dust Extraction Tuck Point Guard and Diamond Blade

- Powerful 10.0 AMP motor delivers more output and 11,000 RPM
- SJS™ II provides a leaf spring and cam gear drive mechanism that is engineered to reduce vibration for increased operator comfort during extended use
- Includes 5" dust extraction tuck point guard for clean and accurate tuck pointing and cutting
- Labyrinth construction seals and protects the motor and bearings from dust and debris for longer tool life

Model GA5040X1 Includes: 5" Dust Extracting Tuck Point Guard (196845-3), Inner Flange (224399-1), Lock Nut Wrench (782412-6), 5" Dual Sandwich Diamond Tuck Point Blade (A-96017), 5" Tool-less Wheel Guard (123145-8), Side Handle (162258-0)

Wheel Diameter	5"
AMPS	10
No Load Speed	11,000 RPM
Spindle Thread	5/8" - 11 UNC
Lock-On: Yes	Lock-Off: No
Grinder Switch Type	Body grip/slide
Overall Length	11-7/8"
Net Weight	5.4 lbs.
Shipping Weight	12 lbs.

SJS II GA5042CX1 HIGH POWER 12

5" SJS™ II HIGH-POWER GRINDER WITH TUCK POINT GUARD 5" Dust Extraction Tuck Point Guard and Diamond Blade

- Powerful 12.0 AMP motor delivers more output and variable (2,800 - 11,000) RPM
- SJS™ II provides a leaf spring and cam gear drive mechanism that is engineered to reduce vibration for increased operator comfort during extended use
- Includes a 5" dust extraction tuck point guard for clean and accurate tuck pointing and cutting

Model GA5042CX1 Includes: 5" Dust Extracting Tuck Point Guard (196845-3), Inner Flange (224399-1), Lock Nut Wrench (782412-6), 5" Dual Sandwich Diamond Tuck Point Blade (A-96017), 5" Tool-less Wheel Guard (123145-8), Lock Nut (224568-4)

Wheel Diameter	5"
AMPS	12
No Load Speed (variable speed)	2,800 - 11,000 RPM
Spindle Thread	5/8" - 11 UNC
Lock-On: Yes	Lock-Off: No
Grinder Switch Type	Body grip/slide
Overall Length	11-7/8"
Net Weight	5.4 lbs.
Shipping Weight	13 lbs.



SJS GA5020 AC/DC

5" SJS™ ANGLE GRINDER Electric Brake for Maximum Productivity

- Powerful 10.5 AMP motor delivers 11,000 RPM to handle the most demanding applications
- SJS™ technology is a mechanical clutch system that helps prevent motor and gear damage by allowing the drive shaft to slip
- "Tool-less" wheel guard for more convenient adjustments
- AC/DC switch for use with alternative power source
- No lock-on feature for more convenience

Model GA5020 Includes: 5" x 1/4" x 7/8" INOX Grinding Wheel, 36 Grit (A-95962), 5" Tool-less Wheel Guard (135108-2), Inner Flange (224399-1), Lock Nut (193465-4), Lock Nut Wrench (782424-9), Side Handle (153504-2)

Wheel Diameter	5"
AMPS	10.5
No Load Speed	11,000 RPM
Spindle Thread	10.5
Lock-On: No	Lock-Off: No
Grinder Switch Type	Rear trigger switch
Overall Length	14"
Net Weight	5.9 lbs.
Shipping Weight	8.8 lbs.



SJS GA5020Y AC/DC

5" SJS™ ANGLE GRINDER Electric Brake for Maximum Productivity

- Powerful 10.5 AMP motor delivers 11,000 RPM to handle the most demanding applications
- SJS™ technology is a mechanical clutch system that helps prevent motor and gear damage by allowing the drive shaft to slip
- "Tool-less" wheel guard for more convenient adjustments
- AC/DC switch for use with alternative power source
- No lock-on feature for more convenience

Model GA5020Y Includes: 5" x 1/4" x 7/8" INOX Grinding Wheel, 36 Grit (A-95962), 5" Tool-less Wheel Guard (135108-2), Inner Flange (224399-1), Lock Nut (193465-4), Lock Nut Wrench (782424-9), Side Handle (153504-2)

Wheel Diameter	5"
AMPS	10.5
No Load Speed	11,000 RPM
Spindle Thread	5/8" - 11 UNC
Lock-On: No	Lock-Off: Yes
Grinder Switch Type	Rear trigger switch
Overall Length	14"
Net Weight	5.9 lbs.
Shipping Weight	7.9 lbs.



SJS GA5010Z AC/DC

5" ANGLE GRINDER 10.5 AMP Motor and Labyrinth Construction

- Powerful 10.5 AMP motor delivers more output for increased performance
- Refined design at only 5.8 lbs.
- AC/DC switch for use with alternative power source
- Labyrinth construction seals and protects motor and bearings from contamination
- Externally accessible brushes for greater serviceability

Model GA5010Z Includes: 5" x 1/4" x 7/8" INOX Grinding Wheel, 36 Grit (A-95962), Side Handle (153504-2), 5" Tool-less Wheel Guard (135108-2), Inner Flange (224399-1), Lock Nut (193465-4), Lock Nut Wrench (782424-9)

Wheel Diameter	5"
AMPS	10.5
No Load Speed	11,000 RPM
Spindle Thread	5/8" - 11 UNC
Lock-On: No	Lock-Off: No
Grinder Switch Type	Rear trigger switch
Overall Length	14"
Net Weight	5.8 lbs.
Shipping Weight	8.8 lbs.



SJS 9566PC / 9566PCX1 HIGH POWER 13

6" SJS™ PADDLE SWITCH CUT-OFF/ ANGLE GRINDER SJS™ Mechanical Clutch System Helps Prevent Motor and Gear Damage

- Powerful 13.0 AMP motor delivers more output and 9,000 RPM
- Constant speed control automatically applies additional power to the motor to maintain speed under load
- Soft start suppresses start-up reaction for smooth start-ups and longer gear life

Model 9566PC Includes: Side Handle (153489-2), 6" Cut-Off Wheel Guard (165486-6), Inner Flange, 9566CV/PC (224390-9), Lock Nut (224574-9), Lock Nut Wrench (782424-9), 6" Cut-off Wheel, Metal (724117-A-25)

Model 9566PCX1 Includes: Same as 9566PC plus 6" x 1/4" x 7/8" Inox Grinding Wheel, 36 Grit (A-95978) and 6" Tool-Less Wheel Guard (135172-3)

Wheel Diameter	6"
AMPS	13
No Load Speed	9,000 RPM
Spindle Thread	5/8" - 11 UNC
Lock-On: No	Lock-Off: Yes
Grinder Switch Type	Body grip/paddle
Overall Length	12-1/8"
Net Weight	5.5 lbs.
Shipping Weight	9566PC (7.5 lbs.), 9566PCX1 (9.5 lbs.)



9566CV

MAX POWER
12

6" SJS™ CUT-OFF/ANGLE GRINDER

Electronic Controller for Increased Durability

- Powerful 12.0 AMP motor delivers more output and 9,000 RPM
- Variable speed control dial enables user to match the speed to the application
- Constant speed control automatically applies additional power to the motor to maintain speed under load
- Soft start suppresses start-up reaction for smooth start-ups and longer gear life
- Electronic current limiter helps protect the motor from overload

Model 9566CV Includes: Lock Nut Wrench (782412-6), Lock Nut (224574-9), Side Handle (153489-2), Inner Flange, 9566CV/PC (224390-9), 6" Cut-Off Wheel Guard (165486-6), 6" x 7/8" x 1/16" Super Thin Cut-off Wheel, Metal (724117-A)

Wheel Diameter	6"
AMPS	12
No Load Speed (variable speed)	4,000 - 9,000 RPM
Spindle Thread	12.0
Lock-On: Yes	Lock-Off: No
Grinder Switch Type	Body grip/slide
Overall Length	11-3/4"
Net Weight	5.3 lbs.
Shipping Weight	7.7 lbs.



GA6020YX1

AC/DC

6" SJS™ CUT-OFF/ANGLE GRINDER

Electric Brake for Maximum Productivity

- Powerful 10.5 AMP motor delivers 10,000 RPM to handle the most demanding applications
- SJS™ technology is a mechanical clutch system that helps prevent motor and gear damage by allowing the drive shaft to slip
- Zig-zag varnish protects the armature coil from dust and debris for longer motor life
- Labyrinth construction prevents debris from penetrating the motor, bearings and gears for longer tool life

Model GA6020YX1 Includes: 6" x 1/4" x 7/8" INOX Grinding Wheel, 36 Grit (A-95978), Side Handle (153504-2), 6" Tool-less Wheel Guard (135172-3), Inner Flange (224361-6), Lock Nut (193465-4), 6" Cut-Off Wheel Guard (165744-0), Inner Flange, 9566CV/PC (224390-9), Lock Nut (224574-9), Lock Nut Wrench (782424-9), 6" x 7/8" x 1/16" Super Thin Cut-off Wheel, Metal (724117-A)

Wheel Diameter	6"
AMPS	10.5
No Load Speed	10,000 RPM
Spindle Thread	10.5
Lock-On: No	Lock-Off: Yes
Grinder Switch Type	Rear trigger switch
Overall Length	14"
Net Weight	6.7 lbs.
Shipping Weight	10 lbs.



GA6020

AC/DC

6" SJS™ ANGLE GRINDER

Electric Brake for Maximum Productivity

- Powerful 10.5 AMP motor delivers 10,000 RPM
- SJS™ technology is a mechanical clutch system that helps prevent motor and gear damage by allowing the drive shaft to slip
- Spiral bevel gears for smoother rotations and a more efficient transfer of energy
- Zig-zag varnish protects the armature coil from dust and debris for longer motor life
- "Tool-less" wheel guard for more convenient adjustments

Model GA6020 Includes: 6" x 1/4" x 7/8" INOX Grinding Wheel, 36 Grit (A-95978), Side Handle (153504-2), 6" Tool-less Wheel Guard (135172-3), Inner Flange (224361-6), Lock Nut (193465-4), Lock Nut Wrench (782424-9)

Wheel Diameter	6"
AMPS	10.5
No Load Speed	10,000 RPM
Spindle Thread	10.5
Lock-On: No	Lock-Off: No
Grinder Switch Type	Rear trigger switch
Overall Length	14"
Net Weight	6.7 lbs.
Shipping Weight	8.75 lbs.



GA6010Z

AC/DC

6" CUT-OFF/ANGLE GRINDER

AC/DC Switch for Use with Alternative Power Source

- Powerful 10.5 AMP motor delivers more output for increased performance
- Labyrinth construction seals and protects motor and bearings from contamination
- Two position adjustable side handle for operator convenience
- Rear handle and trigger design for more comfort during extended use
- Externally accessible brushes for greater serviceability

Model GA6010Z Includes: Side Handle (153504-2), 6" Cut-Off Wheel Guard (165486-6), Lock Nut Wrench (782424-9), Inner Flange, 9566CV/PC (224390-9), Lock Nut (224574-9), 6" x 7/8" x 1/16" Super Thin Cut-off Wheel, Metal (724117-A)

Wheel Diameter	6"
AMPS	10.5
No Load Speed	10,000 RPM
Spindle Thread	10.5
Lock-On: No	Lock-Off: No
Grinder Switch Type	Rear trigger switch
Overall Length	14"
Net Weight	5.9 lbs.
Shipping Weight	8.8 lbs.



GA7011C

7" ANGLE GRINDER

Electronic Controller for Increased Durability

- Powerful 15.0 AMP motor delivers 6,000 RPM
- Constant speed control automatically applies additional power to the motor to maintain speed under load
- Soft start suppresses start-up reaction for smooth start-ups and longer gear life
- Electronic current limiter helps protect the motor from overload
- "Tool-less" wheel guard for more convenient adjustments

Model GA7011C Includes: 7" x 7/8" x 1/4" Grinding Wheel, 24 Grit, General Purpose Metal (741413-3), Lock Nut Wrench (782412-6), Lock Nut (193465-4), Side Handle (152539-0), Inner Flange (224317-9)

Wheel Diameter	7"
AMPS	15
No Load Speed	6,000 RPM
Spindle Thread	10.5
Lock-On: Yes	Lock-Off: Yes
Grinder Switch Type	Rear trigger handle
Overall Length	17-7/8"
Net Weight	7.5 lbs.
Shipping Weight	11.91 lbs.



GA7020

AC/DC

7" ANGLE GRINDER

Powerful 15.0 AMP Motor Delivers 8,500 RPM

- Spiral bevel gears for smoother rotations and a more efficient transfer of energy
- Labyrinth construction prevents debris from penetrating the motor, bearings and gears for longer tool life
- Zig-zag varnish protects the armature coil from dust and debris for longer motor life
- Externally accessible brushes for easy serviceability
- "Tool-less" wheel guard for more convenient adjustments

Model GA7020 Includes: 7" x 7/8" x 1/4" Grinding Wheel, 24 Grit, General Purpose Metal (741413-3), Side Handle (152539-0), 7" Tool-less Wheel Guard (122767-1), Inner Flange (224317-9), Lock Nut (193465-4), Lock Nut Wrench (782412-6)

Wheel Diameter	7"
AMPS	15
No Load Speed	8,500 RPM
Spindle Thread	10.5
Lock-On: Yes	Lock-Off: No
Grinder Switch Type	Rear trigger handle
Overall Length	18-5/8"
Net Weight	12.2 lbs.
Shipping Weight	15.4 lbs.



GA7021

AC/DC

7" ANGLE GRINDER

Powerful 15.0 AMP Motor Delivers 6,000 RPM

- Spiral bevel gears for smoother rotations and a more efficient transfer of energy
- Labyrinth construction prevents debris from penetrating the motor, bearings and gears for longer tool life
- Zig-zag varnish protects the armature coil from dust and debris for longer motor life
- Externally accessible brushes for easy serviceability
- "Tool-less" wheel guard for more convenient adjustments

Model GA7021 Includes: 7" x 7/8" x 1/4" Grinding Wheel, 24 Grit, General Purpose Metal (741413-3), Side Handle (152539-0), 7" Tool-less Wheel Guard (122767-1), Inner Flange (224317-9), Lock Nut (193465-4), Lock Nut Wrench (782412-6)

Wheel Diameter	7"
AMPS	15
No Load Speed	6,000 RPM
Spindle Thread	10.5
Lock-On: Yes	Lock-Off: No
Grinder Switch Type	Rear trigger handle
Overall Length	18-5/8"
Net Weight	12.2 lbs.
Shipping Weight	15.4 lbs.



GA7040S

7" ANGLE GRINDER

Soft Start Suppresses Start-Up Reaction

- Powerful 15.0 AMP motor delivers 8,000 RPM
- Rear handle rotates with just the push of a button
- Vibration absorbing side handle provides increased comfort
- Spiral bevel gears for smoother rotations and a more efficient transfer of energy
- "Tool-less" wheel guard for more convenient adjustments

Model GA7040S Includes: 7" x 7/8" x 1/4" Grinding Wheel, 24 Grit, General Purpose Metal (741413-3), Side Handle (152539-0), 7" Tool-less Wheel Guard (122767-1), Inner Flange (224317-9), Lock Nut (193465-4), Lock Nut Wrench (782412-6)

Wheel Diameter	7"
AMPS	15
No Load Speed	8,000 RPM
Spindle Thread	10.5
Lock-On: Yes	Lock-Off: No
Grinder Switch Type	Rear trigger handle
Overall Length	20-1/8"
Net Weight	14.2 lbs.
Shipping Weight	17.3 lbs.



GA7031Y

AC/DC

7" ANGLE GRINDER

Rear Handle Rotates With Just the Push of a Button

- Powerful 15.0 AMP motor delivers 8,500 RPM
- Vibration absorbing side handle provides increased comfort on the job
- Wire mesh intake covers are engineered to prevent debris from entering motor
- Spiral bevel gears for smoother rotations and a more efficient transfer of energy
- "Tool-less" wheel guard for more convenient adjustments

Model GA7031Y Includes: Lock Nut Wrench (782412-6), 7" Tool-less Wheel Guard (122767-1), Side Handle (162264-5), Inner Flange (224317-9), Wire Mesh Intake Cover (194289-1)

Wheel Diameter	7"
AMPS	15
No Load Speed	8,500 RPM
Spindle Thread	10.5
Lock-On: No	Lock-Off: Yes
Grinder Switch Type	Rear trigger switch
Overall Length	19-7/8"
Net Weight	13.5 lbs.
Shipping Weight	18 lbs.



GA7001L

AC/DC

7" ANGLE GRINDER

Rugged All Metal Housing for Longer Tool Life

- Powerful 15.0 AMP motor delivers 6,000 RPM
- Enlarged all ball bearing construction for longer tool life
- Spiral bevel gears for smoother rotations and a more efficient transfer of energy
- Zig-zag varnish protects the armature coil from dust and debris for longer motor life
- AC/DC switch for use with alternative power source

Model GA7001L Includes: 7" x 7/8" x 1/4" Grinding Wheel, 24 Grit, General Purpose Metal (741413-3), 7" Wheel Guard (164477-4), Inner Flange (224111-9), Lock Nut (224512-1), Lock Nut Wrench (782412-6), Side Handle (152492-0), Spindle Washer (261039-0)

Wheel Diameter	7"
AMPS	15
No Load Speed	6,000 RPM
Spindle Thread	10.5
Lock-On: Yes	Lock-Off: No
Grinder Switch Type	Rear trigger switch
Overall Length	16-1/4"
Net Weight	12.6 lbs.
Shipping Weight	17.5 lbs.



GA7911

AC/DC

ANGLE SANDER

Rugged All Metal Housing for Longer Tool Life

- Powerful 15.0 AMP motor delivers 6,000 RPM
- Enlarged all ball bearing construction for longer tool life
- Spiral bevel gears for smoother rotations and a more efficient transfer of energy
- Zig-zag varnish protects the armature coil from dust and debris for longer motor life
- AC/DC switch for use with alternative power source

Model GA7911 Includes: Side Handle (152492-0), Spindle Washer (261039-0)

Grinding Wheels	7" or 9"
AMPS	15
No Load Speed	6,000 RPM
Spindle Thread	5/8" - 11 UNC
Lock-On: Yes	Lock-Off: No
Overall Length	16-1/4"
Net Weight	12.2 lbs.
Shipping Weight	13 lbs.



GA9020

AC/DC

9" ANGLE GRINDER

AC/DC Switch for Use with Alternative Power Sources

- Powerful 15.0 AMP motor delivers 6,000 RPM for the most demanding applications
- Spiral bevel gears for smoother rotations and a more efficient transfer of energy
- Labyrinth construction prevents debris from penetrating the motor, bearings and gears for longer tool life
- Zig-zag varnish protects the armature coil from dust and debris for longer motor life
- "Tool-less" wheel guard for more convenient adjustments

Model GA9020 Includes: 9" Grinding Wheel (741421-4), 9" Tool-less Wheel Guard (122768-9), Lock Nut (193465-4), Side Handle (152539-0), Inner Flange (224317-9), Lock Nut Wrench (782412-6)

Wheel Diameter	9"
AMPS	15
No Load Speed	6,000 RPM
Spindle Thread	10.5
Lock-On: Yes	Lock-Off: No
Grinder Switch Type	Rear trigger handle
Overall Length	18-5/8"
Net Weight	12.8 lbs.
Shipping Weight	17.2 lbs.



GA9031Y

AC/DC

9" ANGLE GRINDER

Rear Handle Rotates With Just the Push of a Button

- Powerful 15.0 AMP motor delivers 6,600 RPM
- Three position vibration absorbing side handle for increased comfort
- Wire mesh intake covers are engineered to prevent debris from entering motor
- Spiral bevel gears for smoother rotations and a more efficient transfer of energy
- "Tool-less" wheel guard for more convenient adjustments

Model GA9031Y Includes: Lock Nut Wrench (782412-6), 9" Tool-less Wheel Guard (122768-9), Side Handle (162264-5), Inner Flange (224317-9), Wire Mesh Intake Cover (194289-1)

Wheel Diameter	9"
AMPS	15
No Load Speed	6,600 RPM
Spindle Thread	10.5
Lock-On: No	Lock-Off: Yes
Grinder Switch Type	Rear trigger switch
Overall Length	19-7/8"
Net Weight	14 lbs.
Shipping Weight	18 lbs.



GA9040S

9" ANGLE GRINDER

Soft Start Suppresses Start-Up Reaction

- Powerful 15.0 AMP motor delivers 6,000 RPM
- Rotatable back handle for increased comfort in various orientations
- Three position vibration absorbing side handle for increased comfort
- Spiral bevel gears for smoother rotations and a more efficient transfer of energy
- "Tool-less" wheel guard for more convenient adjustments

Model GA9040S Includes: 9" Grinding Wheel (741421-4), 9" Tool-less Wheel Guard (122768-9), Lock Nut (193465-4), Side Handle (152539-0), Inner Flange (224317-9), Lock Nut Wrench (782412-6)

Wheel Diameter	9"
AMPS	15
No Load Speed	6,000 RPM
Spindle Thread	10.5
Lock-On: Yes	Lock-Off: No
Grinder Switch Type	Rear trigger handle
Overall Length	20-1/8"
Net Weight	14.8 lbs.
Shipping Weight	19.9 lbs.



GS5000

5" STRAIGHT GRINDER

Powerful 7.0 AMP Motor Delivers More Output and 5,600 RPM

- "Tool-less" guard cap removal for more convenient wheel changes
- Rubberized gear housing and handle for operator comfort
- Spiral bevel gears for smoother rotations and a more efficient transfer of energy
- Externally accessible brushes for easier serviceability
- Zig-zag varnish protects the armature coil from dust and debris

Model GS5000 Includes: Wrench (783204-6), Wrench Holder (410047-0), (252105-4)

Max. Wheel Diameter	5"
AMPS	7
No Load Speed	5,600 RPM
Spindle Thread	10.5
Lock-On: No	Lock-Off: Yes
Overall Length	23-1/4"
Net Weight	11.1 lbs.
Shipping Weight	14.45 lbs.



GD0801C

1/4" SJS™ PADDLE SWITCH DIE GRINDER

Electronic Controller for Operator Convenience

- Powerful 6.6 AMP motor delivers 7,000-29,000 RPM for faster material removal
- SJS™ technology is a mechanical clutch system that helps prevent motor and gear damage by allowing the drive shaft to slip
- Variable speed control dial enables user to match the speed to the application
- Soft start suppresses start-up reaction for smooth start-ups and longer gear life

Model GD0801C Includes: 1/4" Collet (192986-3), Spanner Wrench (781203-2), Side Handle (192985-5), Wrench #19 (781206-6)

Max. Wheel Diameter	2"
AMPS	6.6
Collet	1/4"
No Load Speed (variable speed)	7,000 - 29,000 RPM
Lock-On: No	Lock-Off: Yes
Overall Length	14-3/8"
Net Weight	4.2 lbs.
Shipping Weight	7 lbs.



GD0800C

1/4" SJS™ DIE GRINDER
Electronic Controller

- Powerful 6.6 AMP motor delivers 7,000-28,000 RPM
- SJS™ technology is a mechanical clutch system that helps prevent motor and gear damage by allowing the drive shaft to slip
- Variable speed control dial enables user to match the speed to the application
- Constant speed control automatically applies additional power to the motor to maintain speed under load
- Soft start suppresses start-up reaction for smooth start-ups and longer gear life

Model GD0800C Includes: 1/4" Collet (192986-3), Spanner Wrench (781203-2), Side Handle (192985-5), Wrench #19 (781206-6)



GD0600

AC/DC

1/4" PADDLE SWITCH DIE GRINDER
Large Flush-Mount Paddle Switch for Easy Operation

- Powerful 3.5 AMP motor delivers 25,000 RPM
- Lower noise at 73dB(A)
- Small diameter barrel grip for added comfort
- Directional air-flow vents channel the tool's air output away from the user's face
- Round-shaped collet nut is engineered to prevent damages/scratches to work surface

Model GD0600 Includes: (2) Spanner Wrench (781039-9), (2) 1/4" Collet (763625-8)



GD0601

AC/DC

1/4" DIE GRINDER
Side Switch for Operator Convenience

- Powerful 3.5 AMP motor delivers 25,000 RPM
- Lower noise at 73dB(A)
- Small diameter barrel grip for added comfort
- Directional air-flow vents channel the tool's air output away from the user's face
- Round-shaped collet nut is engineered to prevent damages/scratches to workpiece

Model GD0601 Includes: Spanner Wrench (781039-9), 1/4" Collet (763625-8)



XDG01

3.0Ah BATTERY

18v LXT® 1/4" DIE GRINDER KIT
Delivers 25,000 RPM for Faster Grinding

- Compact barrel grip design and weighs only 4.4 lbs. for easy handling
- Slide switch with lock-on for operator convenience
- Vent slots designed to direct exhaust air away from the user
- L.E.D. light flashes red when it is time to recharge the battery
- Built-in L.E.D. protection circuit with over-torque control protects the motor

Model XDG01 Includes: (2) 18V LXT® Lithium-Ion 3.0Ah Battery (BL1830), 18V Lithium-Ion Rapid Optimum Charger (DC18RC), 1/4" Collet (763625-8), (2) Spanner Wrench (781039-9), Tool Bag

Model XDG01Z Includes: Tool Only; Battery and Charger not included

Max. Wheel Diameter	2"
AMPS	6.6
Collet	1/4"
No Load Speed (variable speed)	7,000 - 28,000 RPM
Lock-On: Yes	Lock-Off: No
Overall Length	14-5/8"
Net Weight	3.7 lbs.
Shipping Weight	5.6 lbs.

Max. Wheel Diameter	1-1/2"
AMPS	3.5
Collet	1/4"
No Load Speed	25,000 RPM
Lock-On: No	Lock-Off: Yes
Overall Length	14-1/8"
Net Weight	3.7 lbs.
Shipping Weight	5.1 lbs.

Max. Wheel Diameter	1-1/2"
AMPS	3.5
Collet	1/4"
No Load Speed	25,000 RPM
Lock-On: Yes	Lock-Off: No
Overall Length	14-1/8"
Net Weight	3.7 lbs.
Shipping Weight	6.6 lbs.

Max. Wheel Diameter	1-1/2"
Collet	1/4"
No Load Speed	25,000 RPM
Lock-On: Yes	Lock-Off: No
Battery	18V LXT® Lithium-Ion
Overall Length	15-3/4"
Net Weight (with battery)	4.4 lbs.
Shipping Weight	14 lbs.

Metalworking Accessories

Angle Grinder Accessory Guide See pg. 108

A Wheel Guards

Description	Grinder Size	Model	Part #
Wheel Guard For all grinding operations except for cut-off wheels	4"	GA4030	125885-4
	4"	9553NB	125475-5
	4-1/2"	9557NB/PB BGA452, XAG01	125890-1
	4-1/2"	9564CV/PC/P	165053-7
	4-1/2"	GA4530, GA4534	122886-3
	4-1/2"	XAG03, XAG06	123144-0
	4-1/2" (tool-less)	9564CV/PC/P	135107-4
	5"	9005B/BZ	135040-0
	5"	9015A	125097-9
	5"	9558PB	125274-3
	5"	9005B/BZ	125549-2
	5" (tool-less)	9565CV/PC, GA5010Z, GA5020/Y	135650-3
	6"	9016B	134961-3
	6" (tall / tool-less)	GA6010Z, GA6020, 9566CV/PC	135172-3
6" (short / tool-less)	GA6010Z, GA6020, 9566CV/PC	135110-5	
7"	GA7001L	164477-4	
7"	GA7911	191214-3	
7" (tool-less)	GA7020, GA7021, GA7040S	122767-1	
7" (tool-less)	GA7011C	122772-8	
9"	GA7911, GA9020, GA9040S	191215-1	
9" (tool-less)	GA9020, GA9040S	122768-9	

Description	Grinder Size	Model	Part #
Cut-Off Wheel Guard For cut-off wheel applications	4-1/2"	BGA452, 9564CV/PC/P, XAG01	135103-2
	4-1/2"	GA4530, GA4534, XAG03, XAG06	122910-2
	5"	9005B/BZ	122688-7
		9558PB,	
	5"	9565CV/PC, GA5010Z, GA5020/Y	122641-3
	6"	GA6010Z, GA6020, 9566CV/PC	165744-0

Description	Grinder Size	Model	Part #
Wheel Guard For dust collecting, cutting	4-1/2" - 5"	9564CV/PC/P, 9565CV/PC	193794-5 (with shoe)
	4-1/2" - 5"	9564CV/PC/P, 9565CV/PC	192618-2
	4-1/2" - 5"	9565CV/PC	196846-1
	4-1/2" - 5"	GA5040, GA5042C	196845-3

B Inner Flanges

Description	Grinder Size	Model	Part #
Inner Flange	4"	GA4030	224377-1
	4"	N9501BZ	224376-3
		9557NB/PB, 9564CV/PC/P,	
	4-1/2", 5", 6"	9558PB, 9565PC, GA5010Z, GA5020, GA4534, XAG01, XAG03, XAG06	224399-1
	4-1/2", 5", 6", 7"	9005B/BZ, 9564CV/PC/P, 9565CV, GA7011C	224378-9
	5", 6" (for use with cut-off wheels)	9005B/BZ, 9527NB, GA6010Z	224361-6
	6"	9566CV/PC	224390-9
	7"	GA7001L, GA7911	224111-9
		9077SL, GA7020, GA7021, GA7040S, GA9020, GA9040S	224317-9

D Lock Nuts

Description	Grinder Size	Model	Part #
Lock Nuts For use with flex wheels	4"	GA4030	224541-4

Description	Grinder Size	Model	Part #
Lock Nuts For use with diamond blade, grinding, cut-off, and multi-disc wheels.	4"	GA4030	194608-1
		9005B/BZ, 9557NB/PB, 9558PB, 9564CV/PC, 9565CV/PC, GA5010Z, GA5020, GA6020, GA7011C, GA7020, GA7021, GA7031Y, GA7040S, GA9020, GA9040S, GA9031Y, XAG01, XAG03, XAG06	193465-4
	4-1/2", 5", 7", 9"		
	6"	9566CV/PC, GA6010Z, GA6020	224574-9
	7"	GA7001L, GA7911	224512-1

² Use with corresponding cut-off wheel guard & lock nut

Description	Grinder Size	Model	Part #
Lock Nut For use with rubber pads	4"	GA4030	224501-6
		9557NB/PB, 9564CV/PC/P, GA4530, GA4534, 9005B/BZ, 9565CV/PC, GA5010Z, GA5020/Y, 9566CV/PC, GA6010, GA6020, GA7001L, GA7011C, GA7020, GA7021, XAG01, XAG03, XAG06	193048-0

Description	Grinder Size	Model	Part #
Wheel Guard For dust collecting, surfacing	4-1/2" - 5"	Makita 4-1/2"-5" Grinders Except 9005B	195236-5
	7"-9"	Makita 7" & 9" Grinders Except GA7911, GA7001L	195386-6 ¹

¹ Accepts wheels up to 7" in diameter



GV5010

5" DISC SANDER

Compact Design at Only 2.6 lbs.

- Powerful 4.2 AMP motor delivers 4,500 RPM
- Precision balance with rubberized soft grip handle for greater comfort
- Spiral bevel gears for smoother rotations and a more efficient transfer of energy
- Zig-zag varnish protects the armature coil from dust and debris for longer motor life
- Lock-on button for continuous operation

Model GV5010 Includes: 5" Abrasive Disc, 80 Grit, 5/pk (742109-9), 5" Plastic Backing Pad (743025-8), Side Handle (152491-2), Hex Wrench (783203-8)

Sanding Disc	5"
No Load Speed	4,500 RPM
AMPS	4.2
Overall Length	7-1/8"
Net Weight	2.6 lbs.
Shipping Weight	2.6 lbs.



9218SB

7" DISC SANDER

Motor-Over-Pad Design for Balance and Control

- 5.2 AMP motor delivers 4,000 RPM for smooth sanding
- Lightweight (6.3 lbs.) for reduced operator fatigue
- Ball-and-needle bearing construction for longer tool life and smooth operation
- Lock-on button for continuous use and reduced operator fatigue
- Double insulated

Model 9218SB Includes: 7" Rubber Backing Pad (192978-2), Lock Nut (193048-0), Spanner Wrench (781008-0), Lock Nut Wrench (782412-6), Side Handle (152492-0), 1 ea. Abrasive Disc 50 Grit (742070-A-5)

Sanding Disc	7"
No Load Speed	4,500 RPM
Spindle Thread	5/8" - 11 UNC
AMPS	5.2
Overall Length	8-7/8"
Net Weight	6.3 lbs.
Shipping Weight	9.7 lbs.



GV7000C

7" DISC SANDER

Lightweight (4.6 lbs.) for Comfort and Control

- Advanced electronics include soft start and electronic speed control
- Variable speed (2,500 - 4,700 RPM)
- Trigger lock-on button for operator convenience
- Motor-over-pad design for better balance and control
- Externally accessible carbon brushes for efficient maintenance

Model GV7000C Includes: 7" Abrasive Disc, 80 Grit, 5/pk (742071-A-5), 7" Rubber Backing Pad (192978-2), Lock Nut (193048-0), Spanner Wrench (781008-0), Lock Nut Wrench (782412-6), Side Handle (152491-2)

Sanding Disc	7"
Wool Bonnet	7"
No Load Speed (variable speed)	2,500 - 4,700 RPM
Spindle Thread	5/8" - 11 UNC
AMPS	7.9
Overall Length	8-1/4"
Net Weight	4.6 lbs.
Shipping Weight	6.62 lbs.



PV7001C

7" VERTICAL POLISHER

High Power-to-Weight Ratio

- Quick-Flip™ speed change for compounding and polishing
- 2-speed selection button: low (600 RPM) and variable (600-2,000 RPM)
- Advanced electronics include soft start and electronic speed control
- Refined design at 4.8 lbs. for reduced operator fatigue
- Motor-over-pad design for improved balance
- Variable speed control dial enables user to match the speed to the application

Model PV7001C Includes: 7" Hook and Loop Backing Pad (743052-5), Air Deflector (417793-6), Spanner Wrench (781008-0), Side Handle (152491-2)

Sanding Disc	7"
Wool Bonnet	7"
No Load Speed	600 RPM
No Load Speed (variable speed)	600 - 2,000 RPM
Spindle Thread	5/8" - 11 UNC
AMPS	7.9
Overall Length	8-1/4"
Net Weight	4.8 lbs.
Shipping Weight	6.7 lbs.



PK5011CX1

5" ELECTRONIC STONE POLISHER

Powerful Stone Edge Work With Water Feed and Splash Guard

- Powerful 11 AMP motor delivers more output for the most demanding applications
- Variable speed control dial (2,000 - 5,500) enables user to match the speed to the application
- Adjustable water flow valve is conveniently located
- Water supply tube is directed through the handle for maneuverability and comfort
- Four water outlets around the arbor efficiently distributes water to the pad for increased dust containment

Model PK5011CX1 Includes: Protective Head Cover (418529-6), Splash Guard (195773-9), Lock Nut Wrench (782412-6), Side Handle (152539-0)

Disc Size (in.)	5"
No Load Speed (variable speed)	2,000 - 5,500 RPM
Spindle Thread	5/8" - 11 UNC
AMPS	11
Overall Length	18-1/2"
Net Weight	8.4 lbs.
Shipping Weight	12.5 lbs.



PW5001C

4" ELECTRONIC STONE POLISHER

Precision Engineered for a Professional Finish

- Variable speed control dial enables user to match the speed to the application
- Soft-start feature for smooth start-ups
- Electronic speed control maintains constant speed under load
- Common fitting accepts the most popular water hose connections
- Includes a Ground Fault Circuit Interrupter (GFCI) plug

Model PW5001C Includes: 4" Rubber Pad (743079-5), Side Handle (153489-2), Head Cover (417322-5), Spanner Wrench (781008-0), Front Grip (418507-6), Wrench (783204-6), Dust Cover (194233-8)

Polishing Disc	4"
No Load Speed (variable speed)	2,000 - 4,000 RPM
Spindle Thread	5/8" - 11 UNC
AMPS	7.9
Overall Length	14-1/8"
Net Weight	5.1 lbs.
Shipping Weight	8.36 lbs.



9237C

7" POLISHER

Electronic Controller for Operator Convenience

- Variable speed dial and trigger enables user to match the speed to the application
- Soft start for smooth start-ups and less fling off of polish, wax or paste
- Rubberized loop handle and gear housing to help protect delicate surfaces from damage
- Wire mesh intake covers to prevent wool fibers from entering the motor
- Lock-on button for continuous use operation
- Includes pad alignment/centering sleeve

Model 9237C Includes: 7" Hook and Loop Backing Pad (743052-5), Wrench (783204-6), Side Handle (153489-2), Loop Handle (455292-0), Pad Alignment/Centering Sleeve (262542-4)

Sanding Disc	7"
Wool Bonnet	8"
No Load Speed (variable speed)	0 - 3,000 RPM
Spindle Thread	5/8" - 11 UNC
AMPS	10
Overall Length	18-1/2"
Net Weight	7 lbs.
Shipping Weight	10 lbs.



9227C

7" POLISHER

Fast and Powerful Polishing for Clearcoat Finishes

- Variable speed control dial enables user to match the speed to the application
- Constant speed control maintains constant speed under load
- Soft start feature for smooth start-ups
- 3 prong plug to prevent static electricity accumulation
- Easily converts to a sander

Model 9227C Includes: 7" Hook and Loop Backing Pad (743052-5), Wrench (783204-6), Side Handle (153489-2), Loop Handle (416256-9)

Sanding Disc	7"
Wool Bonnet	7"
No Load Speed (variable speed)	0 - 3,000 RPM
Spindle Thread	5/8" - 11 UNC
AMPS	10
Overall Length	18-1/2"
Net Weight	6.8 lbs.
Shipping Weight	9 lbs.



JS8000

FIBER CEMENT SHEAR

Cuts Quickly While Producing Less Dust

- Single-piece shear head is machined from precisely milled aluminum to ensure blades cut straight
- Solid steel blades cut clean, straight lines with a maximum cutting capacity up to 5/16"
- 1/2" protected spindle withstands heavy torque loads
- Lightweight cast aluminum gear housing for durability
- Retractable tool hook allows user to work in tight spaces

Model JS8000 Includes: Shear Blade, Center (725129-8), (2) Shear Blade, Side (725130-3), Hex Wrench (783221-6), Tool Case (824780-2)

Capacity	5/16"
Strokes Per Minute (variable speed)	0 - 2,500 SPM
AMPS	6.5
Overall Length	13-5/8"
Net Weight	4.8 lbs.
Shipping Weight	8.5 lbs.



JN3201

10 GAUGE NIBBLER

Powerful 6.2 AMP Motor; 1,300 SPM for the Most Demanding Applications

- Less noise at 81 dB(A) for continuous operation
- Well balanced with a rubberized soft grip handle for greater comfort
- Built-in thickness gauge for added convenience
- Refined design at only 7.4 lbs.
- Lock-on switch for continuous operation

Model JN3201 Includes: Punch (792728-1), Die (792292-2), Hex Wrench (783201-2), Spanner Wrench (781019-5)

Capacities:	Aluminum	10 ga. (mm)
	Mild Steel	10 ga. (mm)
	Stainless	13 ga. (mm)
Strokes Per Minute	1,300 SPM	
Cutting Radius:	Inner Edge	4-3/4"
	Outer Edge	5-1/16"
AMPS	6.2	
Overall Length	8-1/2"	
Net Weight	7.5 lbs.	
Shipping Weight	8.8 lbs.	



JN1601

16 GAUGE NIBBLER

Handles 16 Ga. Mild Steel and 18 Ga. Stainless

- For clean and precise work in keystone plate, deck plate and other sheet materials
- Slim and ergonomic body design for easy gripping
- Die rotates 360°; large 1/4" stroke
- Extremely light (weighs only 3.6 lbs.) for easier handling
- Lock-on sliding switch for continuous use
- Built-in thickness gauge for convenience

Model JN1601 Includes: Spanner Wrench (781028-4), Blade Wrench (783208-8)

Capacities:	Aluminum	10 ga. (mm)
	Mild Steel	16 ga. (mm)
	Stainless	18 ga. (mm)
Strokes Per Minute	2,200 SPM	
Cutting Radius:	Inner Edge	1-3/4"
	Outer Edge	2"
AMPS	5	
Overall Length	10-1/4"	
Net Weight	3.6 lbs.	
Shipping Weight	5.28 lbs.	



XNJ01

18v LXT® 16 GAUGE NIBBLER KIT
Powerful, Versatile and Cordless

- Makita-built motor delivers 1,900 SPM for fast and smooth cutting
- Ideal for cutting roofing sheet metal at thicknesses up to 16 gauge
- Die holder rotates 360° to meet demands of cutting direction
- Convenient chip disposal is below cutting material to minimize damage to cutting surface
- Cutting radius: inner edge 1-3/4"; outer edge 2"

Model XNJ01 Includes: (2) 18V LXT® Lithium-Ion 3.0Ah Battery (BL1830), 18V Lithium-Ion Rapid Optimum Charger (DC18RC), Punch (A-83951), Spanner Wrench (781028-4), Tool Bag

Model XNJ01Z Includes: Tool Only; Battery and Charger not included

Capacities:	Aluminum	12 ga. (mm)
	Mild Steel	16 ga. (mm)
	Stainless	18 ga. (mm)
Strokes Per Minute (variable speed)	0 - 1,900 SPM	
Cutting Radius:	Inner Edge	1-3/4"
	Outer Edge	2"
Battery	18V LXT® Lithium-Ion	
Overall Length	12-3/8"	
Net Weight (with battery)	4.8 lbs.	
Shipping Weight	13.3 lbs.	



JS1300

18 GAUGE STRAIGHT SHEAR

Powerful 6.5 AMP Motor for Continuous Operation

- Cuts up to 18 gauge mild steel, 20 gauge stainless and 13 gauge aluminum
- Pistol grip design for comfort and convenience
- Shear head attachment rotates 360°
- Large variable speed trigger switch for controlled cutting speed
- Retractable belt clip allows operation in tight areas
- Lock-on button for continuous operation

Model JS1300 Includes: Shear Blade, Right (725092-5), Shear Blade, Left (725093-3), Shear Blade, Center (725094-1), Shear Head Assembly (125112-9), Hex Wrench (783215-1)

Capacities:	Aluminum	13 ga. (mm)
	Mild Steel	18 ga. (mm)
	Stainless	20 ga. (mm)
Strokes Per Minute (variable speed)	0 - 2,500 SPM	
AMPS	6.5	
Overall Length	11-7/8"	
Net Weight	3.9 lbs.	
Shipping Weight	5.28 lbs.	



XSJ01

18v LXT® 18 GAUGE STRAIGHT SHEAR KIT

Swivel Shear Head Rotates 360°

- Makita-built 4-pole motor delivers 3,000 strokes per minute for faster cutting
- Cuts up to 18 gauge mild steel and 20 gauge stainless steel
- Weighs only 5.3 lbs. with battery for reduced operator fatigue
- Reversible belt-clip attaches to either side of the tool
- Rubberized soft grip handle provides increased comfort on the job

Model XSJ01 Includes: (2) 18V LXT® Lithium-Ion 3.0Ah Battery (BL1830), 18V Lithium-Ion Rapid Optimum Charger (DC18RC), Tool Bag

Model XSJ01Z Includes: Tool Only; Battery and Charger not included

Capacities:	Mild Steel	18 ga. (mm)
	Stainless	20 ga. (mm)
Strokes Per Minute	3,000 SPM	
Battery	18V LXT® Lithium-Ion	
Overall Length	13-3/4"	
Net Weight (with battery)	5.3 lbs.	
Shipping Weight	14 lbs.	



JS1602

16 GAUGE SHEAR

Cuts 16 Ga. Mild Steel and 18 Ga. Stainless

- Powerful 3.3 AMP motor delivers 4,000 SPM for the most demanding applications
- Small circumference barrel grip (only 2-1/4") for added comfort
- Refined design at only 3.4 lbs. for increased control
- Lock-on slide switch for continuous operation
- Built-in thickness gauge for added convenience
- Large easily replaceable blades with 8 cutting edge each

Model JS1602 Includes: Hex Wrench (783201-2), Shear Blade Set (191383-0)

Capacities:	Aluminum	13 ga. (mm)
	Mild Steel	16 ga. (mm)
	Stainless	18 ga. (mm)
Strokes Per Minute	4,000 SPM	
Cutting Radius	1-3/16"	
AMPS	3.3	
Overall Length	12-1/2"	
Net Weight	3.4 lbs.	
Shipping Weight	4.9 lbs.	



JS3201

10 GAUGE SHEAR

Powerful 6.2 AMP Motor; 1,600 SPM for the Most Demanding Applications

- Less noise at 81 dB(A) for continuous operation
- Tight 2" cutting radius for greater versatility
- Lock-on switch for continuous operation
- Built-in thickness gauge for convenience
- Refined design at only 7.4 lbs. for increased control
- Large, easily replaceable blades with 8 cutting edges each

Model JS3201 Includes: Hex Wrench (783202-0), Shear Blade Set, JS3201 (792287-5), Thickness Gauge (123456)

Capacities:	Aluminum	9 ga. (mm)
	Mild Steel	10 ga. (mm)
	Stainless	13 ga. (mm)
Strokes Per Min.	1,600	
Cutting Radius	2"	
AMPS	6.2	
Overall Length	8-3/8"	
Net Weight	7.4 lbs.	
Shipping Weight	8.8 lbs.	

2107FZ / 2107FZK
PORTABLE BAND SAW
Large 4-3/4" x 4-3/4" Cutting Capacity

- Powerful 6.5 AMP motor with large (4-3/4" x 4-3/4") cutting capacity for demanding applications
- Variable speed control dial (200-350 ft./min.) enables user to match the speed to the application
- Adjustable front handle for greater maneuverability and comfort
- Built-in, high-output fluorescent light illuminates the cutting area for increased visibility
- Dual ball bearing blade guides assist in blade alignment for greater cutting accuracy

Model 2107FZ Includes: 44-7/8" 18TPI Band Saw Blade (792556-A), Hex Wrench (783202-0), Wrench Holder (410048-8)

Model 2107FZK Includes: Same as 2107FZ plus Tool Case

Max. Cutting Capacities:	Round Workpiece 4-3/4" Rectangular Workpiece 4-3/4" x 4-3/4"
No Load Speed (ft./min., var. speed)	200 - 350 ft./min.
AMPS	6.5
Overall Length	20-5/8"
Net Weight	13.1 lbs.
Shipping Weight	2107FZ (17.5 lbs.), 2107FZK (23 lbs.)

LW1400
14" CUT-OFF SAW WITH TOOL-LESS WHEEL CHANGE "Tool-less" Adjustments for Easy Operation and Increased Productivity

- Powerful 15 AMP motor delivers 3,800 RPM for superior performance and durability
- "Tool-less" flange removal for quick and easy blade and wheel changes
- Extra-large spark guard captures and deflects debris away from the surrounding area
- Large cutting capacity; cuts up to 5" round and 4" x 7-5/8" rectangular
- "Tool-less" fence & vice adjustment for quick and easy operation

Model LW1400 Includes: 14" x 1" x 7/64" Abrasive Cut-Off Wheel (A-93859-1)

Blade Diameter	14"
Arbor	1"
Max. Cutting Capacity (at 90°)	5"
No Load Speed	3,800 RPM
AMPS	15
No Tool Blade Change	Yes
Overall Length	20-7/8"
Net Weight	37.9 lbs.
Shipping Weight	50.4 lbs.

LW1401
14" CUT-OFF SAW Large Cutting Capacity; Cuts up to 5" Round and 4" x 7-5/8" Rectangular

- Powerful 15 AMP motor delivers 3,800 RPM for superior performance and durability
- Adjustable spark guard designed to divert sparks
- Two-stage lock-off power button for operator convenience
- Fence adjustment up to 45° for accurate angle cuts; adjusts to 3 locations for various material sizes
- Weights only 37 lbs. for increased job site portability

Model LW1401 Includes: 14" x 1" x 7/64" Abrasive Cut-Off Wheel (A-93859-1)

Blade Diameter	14"
Arbor	1"
Max. Cutting Capacity (at 90°)	5"
No Load Speed	3,800 RPM
AMPS	15
No Tool Blade Change	No
Overall Length	19-3/4"
Net Weight	37 lbs.
Shipping Weight	50.4 lbs.



2414NB shown

2414NB / 2414DB
14" CUT-OFF SAW
Cuts 4-1/2" Round Stock at 45° and 90°

- D-shaped handle for easy gripping
- Lock-off button for user convenience
- Fence adjusts 45° right and left; 3 locations for various material sizes
- Quick release vise for secure material retention and faster, repeated cut-offs
- Spark diversion guard
- Adjustable depth stop for precise, repeatable cutting depth

Model 2414NB Includes: Socket Wrench (782210-8), 14" x 1" x 7/64" Abrasive Cut-Off Wheel (A-93859-1)

Model 2414DB Includes: Same as 2414NB plus AC/DC switch (411478-6)

Blade Diameter	14"
Arbor	1"
Max. Cutting Capacity	at 90° (4-1/2"), at 45° (4-1/2")
No Load Speed	3,800 RPM
AMPS	15
No Tool Blade Change	No
Overall Length	19-3/4"
Net Weight	2414NB (40.6 lbs.), 2414DB (37.1 lbs.)
Shipping Weight	2414NB (49.4 lbs.), 2414DB (42 lbs.)

LC1230
12" METAL CUTTING SAW For Cutting in Pipe, Angle Iron, Conduit and More

- Carbide tipped blade lasts 50X longer than abrasive wheels; cuts clean, accurate and virtually burr free
- Quick release vise for secure stock retention and fast repeated cut-offs
- Lock-off button for user convenience
- Quick release support fence adjusts 0 - 45° for miter cutting
- Shaft lock for easy wheel changes

Model LC1230 Includes: 12" (60T) Carbide-Tipped Metal Cutting Blade Metal (A-90532), Socket Wrench (782210-8), Safety Goggles (191686-2)

Blade Diameter	12"
Arbor	1"
Max. Cutting Capacity	at 90° (4-1/2"), at 45° (3-1/2")
No Load Speed	1,300 RPM
AMPS	15
Overall Length	20-1/4"
Net Weight	42.5 lbs.
Shipping Weight	50.1 lbs.

4114

AC/DC

14" SJS™ ANGLE CUTTER Built in Dust Port for Reduced Dust and Debris when Connected to a Vacuum

- Powerful 15.0 AMP motor delivers 3,800 RPM for the most demanding applications
- SJS™ technology is a mechanical clutch system that helps prevent motor and gear damage by allowing the drive shaft to slip
- Removable base for a closer edge-to-edge cut
- Rubberized handle for increased comfort
- Built-in vacuum attachment port and rubber shield reduces dust and debris
- AC/DC switch for use with alternative power source

Model 4114 Includes: Socket Wrench (782210-8)

Arbor	1"
Max. Cutting Depth: 14" diamond blade 14" cut-off wheel	5" 5"
No Load Speed	3,800 RPM
AMPS	15
Overall Length	26-1/2"
Net Weight	23.8 lbs.
Shipping Weight	30.4 lbs.

4131
7-1/4" METAL CUTTING SAW Faster, Cleaner and More Efficient Metal Cutting

- Powerful 13 AMP motor cuts through various types of metal
- Heavy duty blade cover provides increased chip protection
- Virtually spark-free cuts
- CERMET tipped blade leaves burr-free cuts that are cool to the touch
- "Tool-less" blade cover helps prevent heat build-up
- Large cutting capacity for single pass cutting

Model 4131 Includes: 7-1/4" (36T) CERMET Tipped Metal Cutting Blade (A-93815), Hex Wrench (783203-8), Wrench Holder (410047-0), Safety Goggles (191686-2)

Blade Diameter	7-1/4"
Arbor	5/8"
Max. Cutting Depth	2-1/2"
No Load Speed	3,500 RPM
AMPS	13
Overall Length	14-1/8"
Net Weight	10.6 lbs.
Shipping Weight	14.9 lbs.



XSC02Z

BRUSHLESS AUTOMATIC SPEED CHANGE™

XSC02M
XPT™
4.0A BATTERY
18v LXT® BRUSHLESS 5-7/8" METAL CUTTING SAW KIT Cuts 2" Conduit in a Single Pass

- Automatic Speed Change™ technology adjusts cutting speed and torque during cut for optimum performance
- Large cutting capacity (2-1/4" at 90°) allows for 2" conduit to be cut in a single pass
- BL™ Motor delivers 3,900 RPM for faster cutting
- The BL™ Brushless Motor eliminates carbon brushes, enabling the BL™ Motor to run cooler and more efficiently for longer life

Model XSC02M Includes: (2) 18V LXT® Lithium-Ion 4.0Ah Battery (BL1840B), 18V Lithium-Ion Rapid Optimum Charger (DC18RC), 5-7/8" 32T C.T. Saw Blade (A-96095), Tool Bag

Model XSC02Z Includes: Tool Only; Battery and Charger not included

Blade Diameter	5-7/8"
Arbor	5/8"
Max. Cutting Depth	2-1/4"
No Load Speed	3,900 RPM
Battery	18V LXT® Lithium-Ion
Overall Length	13-1/8"
Net Weight (with battery)	6.4 lbs.
Shipping Weight	16 lbs.

**6-1/2" Plunge
Circular Saw**
SP6000J1



SAWS

**CIRCULAR
SAWS**



pgs. 66-68

**MAGNESIUM
CIRCULAR SAWS**



pgs. 66-68

**PLUNGE
CIRCULAR SAWS**



pg. 68

**RECIPRO
SAWS**



pg. 69

JIG SAWS



pg. 70

ACCESSORIES



pgs. 116 - 119

MAGNESIUM™

MORE REFINED

Makita's Magnesium Circular Saws have Magnesium components that deliver saws that weigh less, are well-balanced and jobsite durable. Make large cuts and bevel cuts with positive stops at 0°, 22.5° and 45°. The ergonomic handle is shaped for all-day comfort.

MORE POWER



Powerful 15 AMP motor delivers enough power to cut through the densest lumber

MORE EFFICIENT



Quickly change from 0° to 45° and back using positive stops that are connected to easy-to-grip levers

MORE ACCURACY



Easy-to-read numbers and ruler markings on base and depth guide allow user to measure and follow cuts accurately

MORE REFINED



MAGNESIUM™

5007MG

7-1/4" MAGNESIUM CIRCULAR SAW
Most Refined Saw with Magnesium Components

- Magnesium components create a lightweight saw that's jobsite tough
- Make quick, one-handed adjustments with large, rubberized levers
- Large cutting capacity (2-1/2" at 90°) bevel cuts up to 56° with positive stops at 22.5° and 45°
- Two built-in L.E.D. lights illuminate the line of cut
- Includes premium blade that cuts 50% faster and lasts 2X longer

Model 5007MG Includes: 7-1/4" 24T Ultra-Coated C.T. Saw Blade (A-94530-A), Wrench (783204-6), Rip Fence (164095-8), Tool Case

Blade Diameter	7-1/4"
Arbor	5/8"
Max. Cutting Capacities:	at 90° (2-1/2"), at 45° (1-3/4"), at 56° (1-3/8")
No Load Speed	5,800 RPM
Watts Out	2,300
AMPS	15
Overall Length	12-1/2"
Net Weight	10.6 lbs.
Shipping Weight	17.95 lbs.



5007F / 5007FA

7-1/4" CIRCULAR SAW
#1 Contractor Circular Saw Preferred by Professional Contractors

- Powerful 15 AMP motor delivers 5,800 RPM for proven performance and job site durability
- Lower guard design improves performance when making bevel and narrow cuts
- Two built-in L.E.D. lights illuminate the line of cut for increased accuracy
- Well balanced design for superior handling and performance
- Ideal for framers, builders, masons and siding contractors

Models 5007F & 5007FA Include: 7-1/4" 24T Framing Blade, General Contractor 10/pk (D-45989-10), Wrench (783204-6)

Model 5007FA features an electric brake

Blade Diameter	7-1/4"
Arbor	5/8"
Max. Cutting Capacities:	at 90° (2-3/8"), at 45° (1-3/4")
No Load Speed	5,800 RPM
Watts Out	2,000
AMPS	15
Overall Length	12"
Net Weight	11.1 lbs.
Shipping Weight	5007F (14 lbs.), 5007FA (14.8 lbs.)

MORE POWER, LESS MAINTENANCE



MAGNESIUM™

5377MG

7-1/4" MAGNESIUM HYPOID SAW
Hypoid Gears Deliver More Power to the Blade for More Efficient Cutting

- Magnesium components create a lightweight saw (13.2 lbs.) that is well balanced and job site tough
- Oil bath technology and sealed gear housing for less maintenance
- Large cutting capacity (2-3/8" at 90°) with positive stops at 22.5°, 45° and 51.5°
- Hypoid gears have greater surface contact
- Heat treated hypoid steel gears are designed for less maintenance
- Reinforced 10 ft. cord withstands job site abuse

Model 5377MG Includes: 7-1/4" 24T Ultra-Coated C.T. Saw Blade (A-94530-A), Wrench (783204-6)

Blade Diameter	7-1/4"
Arbor	5/8"
Max. Cutting Capacities:	at 90° (2-3/8"), at 45° (1-3/4"), at 50° (1-9/16")
No Load Speed	4,500 RPM
Watts Out	2,300
AMPS	15
Overall Length	17-3/4"
Net Weight	13.2 lbs.
Shipping Weight	17.35 lbs.



5477NB

7-1/4" HYPOID SAW
Heat-Treated Hypoid Gears are Designed for Less Maintenance

- Hypoid gears deliver more power and have greater surface contact than conventional worm drive gears
- Powerful 15 AMP motor for increased productivity
- Oil bath technology and sealed gear housing for less maintenance
- 0° - 51.5° bevel capacity with positive stops at 45° and 51.5°, ideal for truss and rafter cut-outs
- Large cutting capacity (2-3/8" at 90°; 1-3/4" at 45°; 1-9/16" at 50°)

Model 5477NB Includes: 7-1/4" 24T Framing Blade, General Contractor (D-45989-1), Wrench (783204-6)

Blade Diameter	7-1/4"
Arbor	5/8"
Max. Cutting Capacities:	at 90° (2-3/8"), at 45° (1-3/4"), at 50° (1-9/16")
No Load Speed	4,500 RPM
Watts Out	2,300
AMPS	15
Overall Length	17-3/8"
Net Weight	14.3 lbs.
Shipping Weight	18.07 lbs.



MAGNESIUM™

5007MGA

7-1/4" MAGNESIUM CIRCULAR SAW
More Refined Saw with Magnesium Components and an Electric Brake

- Magnesium components create a lightweight saw that's jobsite tough
- Large cutting capacity (2-1/2" at 90°) bevel cuts up to 56° with positive stops at 22.5° and 45°
- Two built-in L.E.D. lights illuminate the line of cut for increased accuracy
- Electric brake for maximum productivity
- Make quick, one-handed adjustments with large, rubberized levers

Model 5007MGA Includes: 7-1/4" 24T Ultra-Coated C.T. Saw Blade (A-94530-A), Wrench (783204-6), Rip Fence (164095-8), Tool Case

Blade Diameter	7-1/4"
Arbor	5/8"
Max. Cutting Capacities:	at 90° (2-1/2"), at 45° (1-3/4"), at 56° (1-3/8")
No Load Speed	5,800 RPM
Watts Out	2,300
AMPS	15
Overall Length	12-1/2"
Net Weight	10.6 lbs.
Shipping Weight	17.9 lbs.



HS7600

7-1/4" CIRCULAR SAW
Well-balanced and Lightweight (8.6 lbs.)

- Powerful 10.5 AMP motor deliver 5,200 RPM for performance and job site durability
- Lower guard design improves performance when making bevel and narrow cuts
- Heavy gauge aluminum wraparound base engineered for improved durability and straighter cuts
- Large and easy-to-read markings on base for more precise cutting

Model HS7600 Includes: 7-1/4" 24T Framing Blade, General Contractor (D-45989-1), Hex Wrench (783217-7)

Blade Diameter	7-1/4"
Arbor	5/8"
Max. Cutting Capacities:	at 90° (2-1/2"), at 45° (1-5/8")
No Load Speed	5,200 RPM
Watts Out	1,400
AMPS	10.5
Overall Length	12-1/8"
Net Weight	8.6 lbs.
Shipping Weight	11.9 lbs.



5007NK

7-1/4" CIRCULAR SAW
Improved Design for Increased Performance

- Powerful 15 AMP motor for a high power-to-weight ratio
- Lower guard design improves performance when making bevel and narrow cuts
- Well-balanced design for superior handling and performance
- Bevel cuts 0°-56° with positive stops at 22.5°, and 45° and 56° for quick settings
- Large cutting capacity (2-1/2" at 90°, 1-3/4" at 45° and 1-3/8" at 56°)
- Ideal for framers, roofers, carpenters, masons, and general contractors

Model 5007NK Includes: 7-1/4" 24T Framing Blade, General Contractor (D-45989-1), Wrench (783204-6), Tool Case

Blade Diameter	7-1/4"
Arbor	5/8"
Max. Cutting Capacities:	at 90° (2-1/2"), at 45° (1-3/4"), at 56° (1-3/8")
No Load Speed	5,800 RPM
Watts Out	2,300
AMPS	15
Overall Length	12-1/2"
Net Weight	11 lbs.
Shipping Weight	20 lbs.



NEW 5057KB

7-1/4" CIRCULAR SAW, w/ DUST COLLECTOR
Designed for Cutting Fiber-Cement Materials

- Powerful 13 AMP motor delivers enough power to cut five stacked 5/16" siding boards in a single pass
- Dust collector engineered to reduce the amount of dust created while cutting
- Guard is retractable for easier plunge cuts
- Bearings and switch are protected with dust proof design
- Bevel cuts from 0°-45°
- Includes rip fence for straight cuts

Model 5057KB Includes: 7-1/4" 28T Carbide-Tipped, Fiber Cement Blade (A-90451), Offset Wrench (782016-4), Rip Fence (164095-8)

Blade Diameter	7-1/4"
Arbor	5/8"
Max. Cutting Capacities:	at 90° (2-3/8"), at 45° (1-3/16")
No Load Speed	5,800 RPM
Watts Out	2,100
AMPS	13
Overall Length	14"
Net Weight	11.8 lbs.
Shipping Weight	15.8 lbs.



Z
ZERO VIBRATION™
XSH01Z

18V • 18V • 36V

XSH01X

3.0Ah BATTERY

18v X2 LXT® (36v) 7-1/4" CIRCULAR SAW KIT

Two 18v LXT® Batteries Deliver the Cutting Performance of a Corded Saw¹

- Makita-built motor delivers 4,800 RPM for fast cutting and ripping
- Two 18V LXT® Lithium-Ion batteries deliver up to 2.5X more cuts per charge²
- Large cutting capacity (2-5/8" at 90°) and bevel capacity (0°-50°) with a positive stop at 45°
- Reinforced magnesium base for durability

Model XSH01X Includes: (2) 18V LXT® Lithium-Ion 3.0Ah Battery (BL1830), 18V Lithium-Ion Rapid Optimum Charger (DC18RC), 7-1/4" 24T Ultra-Coated C.T. Saw Blade (A-94530-A), Tool Bag

Model XSH01Z Includes: Tool Only; Battery and Charger not included

Blade Diameter	7-1/4"
Arbor	5/8"
Max. Cutting Capacity:	90° (2-5/8"), 45° (1-7/8"), 50° (1-11/16")
No Load Speed	4,800 RPM
Battery	2X 18V LXT® Lithium-Ion
Overall Length	14"
Net Weight (with battery)	10.1 lbs.
Shipping Weight	19.3 lbs.



Z
ZERO VIBRATION™
XSH03Z

BRUSHLESS
AUTOMATIC SPEED CHANGE™

XSH03MB

4.0Ah BATTERY

18v LXT® BRUSHLESS 6-1/2" CIRCULAR SAW KIT

Automatic Speed Change™ Technology

- BL™ Motor delivers 5,000 RPM for faster cutting and ripping
- Automatic Speed Change™ technology adjusts speed and torque during operation for optimum performance
- Compact and ergonomic design at only 13-3/4" long
- Weighs only 7.3 lbs. with battery for reduced operator fatigue
- Large cutting capacity (2-1/4" at 90°) and bevel capacity (0°-50°)

Model XSH03MB Includes: (2) 18V LXT® Lithium-Ion 4.0Ah Battery (BL1840B), 18V Lithium-Ion Rapid Optimum Charger (DC18RC), 6-1/2" 24T C.T. Saw Blade (A-85092), Tool Bag

Model XSH03Z Includes: Tool Only; Battery and Charger not included

Blade Diameter	6-1/2"
Arbor	5/8"
Max. Cutting Capacity:	90° (2-1/4"), 45° (1-5/8"), 50° (1-7/16")
No Load Speed	5,000 RPM
Battery	18V LXT® Lithium-Ion
Overall Length	13-3/4"
Net Weight (with battery)	7.3 lbs.
Shipping Weight	16 lbs.



5005BA

5-1/2" CIRCULAR SAW
Cuts 2X Lumber at 90°

- Powerful 8.0 AMP motor for faster cutting and improved performance
- Blade-left design improves visibility of cutting line
- Compact and lightweight (6.2 lbs.) for increased comfort
- Electric brake for maximum productivity
- Lock-off button for user convenience
- Shaft lock for fast blade changes

Model 5005BA Includes: 5-1/2" 18T Carbide-Tipped Circular Saw Blade (792335-0), Rip Fence (164095-8), Socket Wrench (782209-3)

Blade Diameter	5-1/2"
Arbor	5/8"
Max. Cutting Capacities:	at 90° (1-3/4"), at 45° (1-3/16")
No Load Speed	8,000 RPM
Watts Out	1,050
AMPS	8
Overall Length	9-13/16"
Net Weight	6.2 lbs.
Shipping Weight	9 lbs.



4101RH

5" MASONRY SAW
For Wet Cutting of Tile, Masonry, Concrete and More

- Powerful 7.9 AMP motor for the most demanding jobs
- Special cover design prevents water from entering into motor housing
- Cuts up to 1-5/8" at 90° and 1" at 45°
- Ground fault circuit interrupter (GFCI) plug
- Lock-on button for continuous operation
- Includes 15 ft. of tubing, water pressure regulator and water valve

Model 4101RH Includes: 5" Diamond Blade, Continuous Rim, Wet Cutting (A-90934), Hex Wrench (783203-8), Spanner Wrench (781011-1)

Blade Diameter	5"
Arbor	3/4"
Max. Cutting Capacities:	at 90° (1-5/8"), at 45° (1")
No Load Speed	13,800 RPM
Watts Out	1,050
AMPS	7.9
Overall Length	9-1/4"
Net Weight	6.5 lbs.
Shipping Weight	9.3 lbs.

¹ Compared to Makita 5007 Series ² Compared to Makita BSS611Z



4100NH

4-3/8" MASONRY SAW
Powerful Cutting in Stone, Masonry, Tile & Concrete

- Powerful 12 AMP motor
- Cuts up to 1-3/8"
- Compact and lightweight at only 6.5 lbs.
- High power to weight ratio; 14,500 RPM
- Lock-off button helps prevent accidental starts
- Flat rear side of motor housing allows for easy blade changes

Model 4100NH Includes: Socket Wrench (782209-3), Spanner Wrench (781011-1), 4" Diamond Blade, Turbo, General Purpose (A-94546)

Blade Diameter	4-3/8"
Arbor	3/4"
Max. Cutting Capacity:	at 90° (1-3/8")
No Load Speed	14,500 RPM
Watts Out	1,500
AMPS	12
Overall Length	8-5/8"
Net Weight	6.5 lbs.
Shipping Weight	9.46 lbs.

SPLINTER-FREE CUTS



CAPACITY

Bevel capacity (-1° to 48°) with positive stops at 22.5° and 45°

SP6000J / SP6000J1

6-1/2" PLUNGE CIRCULAR SAW
Delivers Splinter-Free Cuts

- 12 AMP motor with variable speed control dial (2,000 - 5,200 RPM)
- Close to the wall cutting (11/16") for expanded cutting applications
- Electronic speed control maintains constant speed under load for smooth cutting
- Ideal for cutting large wood panels and other wood materials in confined areas
- Dual front and rear bevel supports provide additional rigidity for precise and accurate bevel cuts

Model SP6000J Includes: 6-1/2" 48T Carbide-Tipped Saw Blade (B-07353), Hex Wrench (783203-B), Interlocking Tool Case

Model SP6000J1 Includes: Same as SP6000J plus 55" Guide Rail (194368-5)

Blade Diameter	6-1/2"
Arbor	20 mm
Max. Cutting Capacities:	at 90° (2-3/16"), at 45° (1-9/16")
No Load Speed (variable speed)	2,000 - 5,200 RPM
Watts Out	1,800
AMPS	12
Overall Length	13-3/8"
Net Weight	SP6000J (9.7 lbs.), SP6000J1 (16.5 lbs.)
Shipping Weight	SP6000J (16.9 lbs.), SP6000J1 (23.6 lbs.)

Plunge Circular Saw Accessories

	Size	Part #
Guide Rail	55"	194368-5
	118"	194367-7
Guide Rail Connector Kit		P-45777
Splinter Guard Replacement Strip	55"	194418-6
	118"	194419-4
Non-Slip Replacement Strip	32.8"	194417-8
Carbide-Tipped Saw Blade 48T	6-1/2"	B-07353
Router Guide Rail Adaptor For use with guide rail		194579-2
Clamp Set For use with guide rail		194385-5
Rip Fence		165447-6
Miter Guide Set For use with guide rail		196664-7
Guide Rail Adapter		NEW 196953-0



MAGNESIUM™

5008MGA

8-1/4" MAGNESIUM CIRCULAR SAW
Largest Cutting Capacity in its Class

- Magnesium components create a lightweight saw (11.4 lbs.) that is well balanced and job site tough
- Large cutting capacity (3" at 90°) and bevel capacity (0° - 50°) with positive stops at 22.5° and 45°
- Two built-in L.E.D. lights illuminate the line of cut for increased accuracy
- Electric brake for maximum productivity
- Powerful 15.0 AMP motor delivers 5,200 RPM for proven performance

Model 5008MGA Includes: 8-1/4" 24T Carbide-Tipped Saw Blade, Framing (D-21521), Wrench (783204-6), Rip Fence (164095-8)

Blade Diameter	8-1/4"
Arbor	5/8"
Max. Cutting Capacities:	at 90° (3"), at 45° (2-1/4"), at 50° (2")
No Load Speed	5,200 RPM
Watts Out	2,300
AMPS	15
Overall Length	13-1/8"
Net Weight	11.4 lbs.
Shipping Weight	15.21 lbs.



5104

10-1/4" CIRCULAR SAW
Cuts 4x Lumber in a Single Pass

- 14 AMP motor delivers enough power to cut beams and timber
- Well balanced and weighs only 20.3 lbs. for increased operator comfort
- Precision gearing with ball-and-needle bearing construction
- Electric brake for maximum productivity
- Large cutting and bevel capacity (3-3/4" at 90° and 2-3/4" at 45°)

Model 5104 Includes: 10-1/4" 24T Carbide-Tipped Saw Blade, Framing (A-94910), Wrench (783204-6), Rip Fence (165499-7)

Blade Diameter	10-1/4"
Arbor	5/8"
Max. Cutting Capacities:	at 90° (3-3/4"), at 45° (2-3/4")
No Load Speed	3,800 RPM
Watts Out	2,100
AMPS	14
Overall Length	16"
Net Weight	20.3 lbs.
Shipping Weight	26.7 lbs.



5402NA

16-5/16" CIRCULAR SAW
Large Cutting Capacity for Beams and Timber

- Powerful 15 AMP motor delivers enough power to cut through pressure treated lumber
- Cuts 6x material at 90° and 4x material at 45° in a single pass
- Weighs only 32.1 lbs. for increased operator comfort
- Electric brake for maximum productivity
- Ideal for cutting large timber and lumber

Model 5402NA Includes: 16-5/16" x 1" 32T Carbide-Tipped Blade (A-90956), Wrench (783204-6), Rip Fence (164019-4), Saw Storage Holder (194701-1)

Blade Diameter	16-5/16"
Arbor	1"
Max. Cutting Capacities:	at 90° (6-3/16"), at 45° (4-3/16")
No Load Speed	2,200 RPM
Watts Out	1,800
AMPS	15
Overall Length	24-1/4"
Net Weight	32.1 lbs.
Shipping Weight	43.4 lbs.

Circular Saw Accessories

Description	Model	Part #
Offset Wrench	5007NK/NFAK, 5007FK/FA, 5007NHK, 5008FA, 5277NB	782016-4
Hex Wrench	4101RH, 4131, 5740NB, HS7600	783203-8
	5007MG, 5007MGA, 5008MGA, 5104, 5377MG, 5402NA	783204-6
Socket Wrench	4100NH, 4200NH, 5005BA	782209-3
Spanner Wrench	4100NH, 4100RH, 4200NH, 5201NA	781011-1
Tool Hook	5277NB	125319-7
Saw Storage Holder	5377MG, 5477NB	125346-4
	5402NA	194701-1
Dust Nozzle	5008MGA	450079-5
Rip Fence	4200NH, 5005BA, 5007F, 5007FA, 5007MG, 5007MGA, 5057KB, 5277NB, 5377MG, 5477NB, 5740NB, HS7600	164095-8
	5477NB, 5377MG, 5740NB, HS7600	165153-3
	5740NB, 5277NB, HS7600	164019-4
	5201NA, 5402NA, 5104	165499-7
Rip Fence Screw	5005BA, 5007FAK, 5007F, 5007FA, 5007NK, 5007MG, 5007MGA, 5057KB, 5277NB, 5377MG, 5477NB, 5402NA	251858-2
	5104	265701-9
	5201NA, 5740NB	924316-8
	4200NH	265724-7



JR3070CT

15 AMP

AVT® RECIPRO SAW - 15 AMP
Anti-Vibration Technology for 2X Less Vibration

- Powerful 15 AMP motor with electronic speed control maintains constant speed under load
- Built-in clutch reduces gear damage by disengaging gears if blade binds
- 4-position orbital/straight cutting action
- Ideal for demolition work and demanding cutting applications
- Large 2-finger trigger with lock-on button for added convenience
- Long 1-1/4" stroke for faster cutting

Model JR3070CT Includes: 6" 6TPI Recipro Saw Blade (723054-A-1), 6" Metal Cutting Recipro Saw Blade, 18TPI (723066-A-1), Steel Tool Case

Length of Stroke	1-1/4"
Strokes Per Minute (variable speed)	0 - 2,800 SPM
AMPS	15
Overall Length	19-1/8"
Net Weight	10 lbs.
Shipping Weight	25.82 lbs.



JR3070CTZ

No Lock-On 15 AMP

AVT® RECIPRO SAW - 15 AMP
Anti-Vibration Technology for 2X Less Vibration

- Powerful 15 AMP motor with electronic speed control maintains constant speed under load
- Built-in clutch reduces gear damage by disengaging gears if blade binds
- 4-position orbital/straight cutting action
- Variable speed control dial to match the speed to the application
- Ideal for framers, carpenters, electricians, plumbers, demolition work and other demanding cutting applications

Model JR3070CTZ Includes: 6" 6TPI Recipro Saw Blade (723054-A-1), 6" Metal Cutting Recipro Saw Blade, 18TPI (723066-A-1), Steel Tool Case

Length of Stroke	1-1/4"
Strokes Per Minute (variable speed)	0 - 2,800 SPM
AMPS	15
Overall Length	19-1/8"
Net Weight	9.6 lbs.
Shipping Weight	24 lbs.



JR3060T

12 AMP

RECIPRO SAW - 12 AMP
4-Position Orbital Cutting Action

- Powerful 12 AMP motor for improved performance
- "Tool-less" blade change and shoe adjustment
- Variable speed trigger(0-2,800 SPM) for precise cutting in a wide variety of materials
- Long 1-1/4" stroke for faster cutting
- All ball and needle bearing construction for longer tool life
- Built-in dust blower clears the line of cut for greater accuracy

Model JR3060T Includes: 6" 6TPI Recipro Saw Blade (723054-A-1), 6" Metal Cutting Recipro Saw Blade, 18TPI (723066-A-1), Tool Case

Length of Stroke	1-1/4"
Strokes Per Minute (variable speed)	0 - 2,800 SPM
AMPS	12
Overall Length	19-1/8"
Net Weight	9.6 lbs.
Shipping Weight	14.6 lbs.



JR3050T

11 AMP

RECIPRO SAW - 11 AMP
Powerful 11.0 AMP Motor for Improved Performance

- Variable speed trigger for precise cutting in a wide variety of applications
- "Tool-less" blade change and shoe adjustment
- Long 1-1/8" stroke for faster cutting
- Well-balanced design (only 7.3 lbs.) for reduced operator fatigue
- Large 2-finger trigger with lock-on button
- Built-in dust blower clears the line of cut for greater accuracy

Model JR3050T Includes: 6" 6TPI Recipro Saw Blade (723054-A-1), 6" Metal Cutting Recipro Saw Blade, 18TPI (723066-A-1), Tool Case

Length of Stroke	1-1/8"
Strokes Per Minute (variable speed)	0 - 2,800 SPM
AMPS	11
Overall Length	17-3/4"
Net Weight	7.3 lbs.
Shipping Weight	13.9 lbs.



JR3050TZ

No Lock-On 11 AMP

RECIPRO SAW - 11 AMP
Powerful 11.0 AMP Motor for Improved Performance

- Variable speed trigger for precise cutting in a wide variety of applications
- "Tool-less" blade change and shoe adjustment
- Long 1-1/8" stroke for faster cutting
- Well-balanced design (only 7.3 lbs.) for reduced operator fatigue
- Built-in dust blower clears the line of cut for greater accuracy
- All ball-and-bearing construction engineered for longer tool life

Model JR3050TZ Includes: 6" 6TPI Recipro Saw Blade (723054-A-1), 6" Metal Cutting Recipro Saw Blade, 18TPI (723066-A-1), Tool Case

AMPS	11
Length of Stroke	1-1/8"
Strokes Per Minute (variable speed)	0 - 2,800 SPM
Overall Length	17-3/4"
Net Weight	7.3 lbs.
Shipping Weight	13.7 lbs.



XRJ03Z

Tool only - battery and charger not included

18v LXT® RECIPRO SAW
2,900 SPM and 1-1/8" Stroke for Fast Cutting

- Makita-built variable speed motor delivers 0-2,900 strokes per minute and a 1-1/8" length stroke to provide faster cutting
- "Tool-less" blade change system allows for faster blade installation and removal for increased productivity
- Compact and ergonomic design at only 17-3/4" long
- Weighs only 7.9 lbs. with battery (battery not included) for reduced operator fatigue
- Rubberized soft grip handle provides increased comfort on the job
- Ergonomic shape fits like a glove with even pressure and easy control

Model XRJ03Z Includes: 6" 6TPI Recipro Saw Blade (723054-A-1); Battery and Charger not included

Length of Stroke	1-1/8"
Max. Cutting Capacity: Pipe (5-1/8"), Wood w/ 12" blade (10")	
Strokes Per Minute (variable speed)	0 - 2,900 SPM
Battery	18V LXT® Lithium-Ion
Overall Length	17-3/4"
Net Weight (with battery)	7.9 lbs.
Shipping Weight	8 lbs.



XRJ02



18v LXT® RECIPRO SAW KIT
"Tool-less" Blade Change and Shoe Adjustment

- Makita-built variable speed motor delivers 0-2,900 strokes per minute and a 1-1/8" stroke length for faster cutting
- Large 2-finger variable speed trigger for added convenience
- Retractable tool hook secures the tool when not in use
- Soft grip handle provides increased comfort on the job
- Compact and ergonomic design at only 19-5/8" long

Model XRJ02 Includes: (2) 18V LXT® Lithium-Ion 3.0Ah Battery (BL1830), 18V Lithium-Ion Rapid Optimum Charger (DC18RC), 6" 6TPI Recipro Saw Blade (723054-A-1), Tool Case

Model XRJ02Z Includes: Tool Only; Battery and Charger not included

Length of Stroke	1-1/8"
Max. Cutting Capacity: Pipe (5-1/8"), Wood w/ 12" blade (10")	
Strokes Per Minute (variable speed)	0 - 2,900 SPM
Battery	18V LXT® Lithium-Ion
Overall Length	19-5/8"
Net Weight (with battery)	8.2 lbs.
Shipping Weight	18 lbs.

NEW Coming Soon

XRJ06Z 18v + 18v + 36v

18v X2 LXT® (36v) BRUSHLESS RECIPRO SAW

XRJ05Z

18v LXT® BRUSHLESS RECIPRO SAW

XRJ04Z

18v LXT® RECIPRO SAW

PRECISION ENGINEERING



SPEED
"Tool-less" blade change system for fast and easy blade installation and removal

VERSATILITY
3 orbital settings plus straight cutting for cutting in all varieties of materials

CAPACITY
Electronic variable speed control dial maintains consistent speed throughout the cut for superior results

4350FCT

TOP HANDLE JIG SAW Precision Engineering Delivers Best-in-Class Cutting

- 3 orbital settings plus straight cutting for use in a variety of materials
- Variable speed control dial (800 - 2,800 SPM) enables user to set the speed to the application
- "Tool-less" blade change system for fast blade installation and removal
- 40% less tool vibration with the lowest noise level in its class
- Uses Tang shank blades

Model 4350FCT Includes: (2) 4-1/8" 9TPI Jig Saw Blade (792529-7-1), (2) Jig Saw Blade, T Shank, HCS, 4-1/8" x 9TPI (792729-9-1), (2) Jig Saw Blade, T Shank, HSS, 3" x 24TPI (792473-8-1), Anti-Splintering Insert (415524-7), Cover Plate (417852-6), Hex Wrench (783202-0), Tool Case

Length of Stroke	1"
Max. Cutting Capacities:	Wood at 90° (5-5/16"), Steel at 90° (3/8")
Strokes Per Minute (variable speed)	800 - 2,800 SPM
Blade Shank	"T" Tang
AMPS	6.3
Overall Length	9-1/4"
Net Weight	5.7 lbs.
Shipping Weight	9.4 lbs.



JV0600K

TOP HANDLE JIG SAW Powerful 6.5 AMP Motor

- 6.5 AMP motor and 3 orbital settings plus straight cutting deliver faster and more accurate cuts
- Variable speed control dial (500-3,100 SPM) enables user to match the speed to the application
- Through-the-body dust port for use with a vacuum provides efficient dust management
- Counterbalance system for reduced vibration
- "Tool-less" blade change system for fast blade installation and removal
- Uses Tang shank blades

Model JV0600K Includes: 4-1/8" 9TPI Jig Saw Blade (792529-7-1), Hex Wrench (783201-2), Tool Case

Length of Stroke	7/8"
Max. Cutting Capacities:	Wood at 90° (3-1/2"), Steel at 90° (3/8")
Strokes Per Minute (variable speed)	500 - 3,100 SPM
Blade Shank	"T" Tang
AMPS	6.5
Overall Length	9-1/4"
Net Weight	5.2 lbs.
Shipping Weight	9.19 lbs.



4329K

TOP HANDLE JIG SAW 3 Orbital Settings Plus Straight Cutting

- Variable speed control dial (500 - 3,100 SPM) enables user to set the speed to the application
- Ergonomically designed rubberized grip for more comfort
- Counterweight balancing system for reduced vibration
- Die-cast aluminum base adjusts up to 45° right or left and positive stop at 90° for solid cutting performance
- Through-the-body dust port provides optimal dust management with use of clear dust cover and vacuum
- Uses Tang shank blades

Model 4329K Includes: 4-1/8" 9TPI Jig Saw Blade (792529-7-1), Hex Wrench (783201-2), Tool Case

Length of Stroke	11/16"
Max. Cutting Capacities:	Wood at 90° (2-9/16"), Steel at 90° (1/4")
Strokes Per Minute (variable speed)	500 - 3,100 SPM
Blade Shank	"T" Tang
AMPS	3.9
Overall Length	8-7/8"
Net Weight	4.2 lbs.
Shipping Weight	7.7 lbs.



LXT
BRUSHLESS

XVJ02Z

Tool only - battery and charger not included

18v LXT® BRUSHLESS JIG SAW Up To 45% Faster Cutting*

- Makita-built brushless motor and 3 orbital settings plus straight cutting deliver faster and more accurate cuts in a variety of materials
- Variable 6-speed control dial (800-3,500 SPM) enables user to match the speed to the application
- Efficient BL™ Brushless motor is electronically controlled to optimize battery energy use for up to 50% longer run time per charge
- "Tool-less" blade change system allows for faster blade installation and removal for increased productivity
- The electronically-controlled BL™ Brushless Motor efficiently uses energy to match torque and SPM to the changing demands of the application

Model XVJ02Z Includes: 4-1/8" 9TPI Jig Saw Blade (792529-7-1); Battery and Charger not included

Length of Stroke	1"
Max. Cutting Capacity at 90°:	Aluminum (25/32"), Mild Steel (3/8"), Wood (5-5/16")
Strokes Per Minute (variable speed)	800 - 3,500 SPM
Blade Shank	"T" Tang
Overall Length	10-1/2"
Net Weight (with battery)	5.8 lbs.
Shipping Weight	5.3 lbs.



LXT
3.0AH BATTERY

XVJ03

18v LXT® JIG SAW KIT Custom Cutting Without a Cord

- Makita-built variable speed motor delivers 0-2,600 strokes per minute for fast and efficient cutting
- 3 orbital settings plus straight cutting for use in a variety of materials
- "Tool-less" blade change system allows for faster blade installation and removal for increased productivity
- Heavy gauge, precision machined base for smooth, accurate cutting and added durability
- Heavy gauge, precision machined base for smooth, accurate cutting and added durability

Model XVJ03 Includes: (2) 18V LXT™ Lithium-Ion 3.0Ah Battery (BL1830), 18V Lithium-Ion Rapid Optimum Charger (DC18RC), Jig Saw Blade, T Shank, HCS, 4-1/8" x 9TPI (792729-9-1), Anti-Splintering Insert (415524-7), Tool Bag
Model XVJ03Z Includes: Tool Only; Battery and Charger not included

Length of Stroke	1"
Max. Cutting Capacity at 90°:	Wood (5-5/16"), Steel (3/8")
Strokes Per Minute (variable speed)	0 - 2,600 SPM
Blade Shank	"T" Tang
Battery	18V LXT™ Lithium-Ion
Overall Length	10-1/8"
Net Weight (with battery)	14.7 lbs.
Shipping Weight	14.7 lbs.

Z
3.0AH BATTERY
XVJ03Z



4351FCT

BARREL GRIP JIG SAW Barrel Grip Design is Closer to the Work Surface for More Precise Cuts

- 40% less tool vibration with the lowest noise level in its class
- 3 orbital settings plus straight cutting for use in a variety of materials
- Variable speed control dial (800 - 2,800 SPM) enables user to set the speed to the application
- "Tool-less" blade change system
- Uses Tang shank blades

Model 4351FCT Includes: (2) 4-1/8" 9TPI Jig Saw Blade (792529-7-1), (2) Jig Saw Blade, T Shank, HCS, 4-1/8" x 9TPI (792729-9-1), (2) Jig Saw Blade, T Shank, HSS, 3" x 24TPI (792473-8-1), Anti-Splintering Insert (415524-7), Cover Plate (417852-6), Hex Wrench (783202-0), Tool Case

Length of Stroke	1"
Max. Cutting Capacities:	Wood at 90° (5-5/16"), Steel at 90° (3/8")
Strokes Per Minute (variable speed)	800 - 2,800 SPM
Blade Shank	"T" Tang
AMPS	6.3
Overall Length	10-3/4"
Net Weight	5.5 lbs.
Shipping Weight	9.2 lbs.

Jig Saw Accessories



Rip Fence / Circular Guide

For fast ripping to uniform width

Type	Models	Part #
Rip Fence Only	4320, 4300BV, 4301BV, 4302C	164113-2
Combination	4340FCT, 4341FCT, 4350FCT, 4351FCT, XVJ02, XVJ03	193516-3

Base Plate / Cover Plate



Type	Models	Part #
Metal Base Plate	4350FCT, 4351FCT, XVJ02, XVJ03	345238-3
Cover Plate	4350FCT, 4351FCT, XVJ02, XVJ03	417852-6

Anti-Splintering Insert

For cleaner cuts

Models	Part #
4350FCT, 4351FCT, XVJ02, XVJ03	415524-7

Guide Rail Adaptor Set

Models	Part #
4350FCT, 4351FCT, XVJ02, XVJ03	193517-1
For use with guide rails	55" 194368-5 118" 194367-7

Additional Jig Saw Accessories See pg. 119

* Compared to XVJ03

**8-1/2" Slide
Compound Miter Saw**
LS0815F

BENCHTOP

MITER SAWS



pgs. 72-73

TABLE SAWS



pg. 74

PLANER



pg. 74

ACCESSORIES



pg. 117

LARGE & ACCURATE CUTS



CAPACITY

Cuts up to 8" crown molding (nested) and 6-1/2" baseboard (vertical)



VERSATILITY

5-1/2" tall fence system features upper and lower fence adjustments for more precise cuts



ACCURACY

6 linear ball bearings and 4-steel rail sliding system deliver maintenance-free "dead-on" accurate cuts



LS1216L

12" DUAL SLIDE COMPOUND MITER SAW

Cuts Up to 8" Crown Molding and 15" at 90°

- 4-Steel Rail Sliding System increases rigidity to produce superior cuts
- 6 linear ball bearings deliver adjustment-free "dead-on" accurate cuts
- 5-1/2" tall dual sliding fence system
- Independent laser indicates line-of-cut whether blade is turning or not
- Electronic speed control maintains constant speed

Model LS1216L Includes: 12" x 1" 60T Micro-Polished Miter Saw Blade (A-93712), Vertical Vise (122854-6), Dust Bag (122852-0), Triangular Rule (762001-3), Blade Wrench (783208-8), Socket Wrench (782232-8)

Blade Diameter	12"
Arbor	1"
Max. Cutting Capacities:	
at 90° (3-5/8" x 15"), at 45° L/R (3-5/8" x 10-1/2")	
No Load Speed	3,200 RPM
Dimensions (LxWxH)	31-3/4" x 25-1/4" x 28-3/8"
Net Weight	58.6 lbs.
Shipping Weight	74 lbs.



LS1216LX4

12" DUAL SLIDE COMPOUND MITER SAW

Cuts Up to 8" Crown Molding and 15" at 90°

- 4-Steel Rail Sliding System increases rigidity to produce superior cuts
- 6 linear ball bearings deliver adjustment-free "dead-on" accurate cuts
- Independent laser indicates line-of-cut whether blade is turning or not
- Includes a durable stand for easier job-site portability that features up to 9' material support extensions and adjustable leg supports

Model LS1216LX4 Includes: 12" x 1" 60T Micro-Polished Miter Saw Blade (A-93712), Vertical Vise (122854-6), Dust Bag (122852-0), Triangular Rule (762001-3), Straight Guide (164834-6), Socket Wrench (782232-8), Jobsite Miter Saw Stand (WST05)

Blade Diameter	12"
Arbor	1"
Max. Cutting Capacities:	
at 90° (3-5/8" x 15"), at 45° L/R (3-5/8" x 10-1/2")	
No Load Speed	3,200 RPM
Dimensions (LxWxH)	31-3/4" x 25-1/4" x 28-3/8"
Net Weight	116.2 lbs.
Shipping Weight	162 lbs.



LS1016

10" DUAL SLIDE COMPOUND MITER SAW

Largest Crown Molding Cutting Capacity in its Class

- 10" slide miter saw with the crown molding cutting capacity of a 12" saw
- Innovative direct drive gearbox and guard system is engineered for increased vertical cutting capacity (4-3/4")
- Exclusive 6 linear ball bearings engineered to deliver "dead-on" accurate cuts
- Capacity: 6-5/8" crown molding (nested), 4-3/4" baseboard (vertical)
- Compact design with a patented 4-Steel Rail Sliding System

Model LS1016 Includes: 10" x 5/8" 60T Micro-Polished Miter Saw Blade (A-93675), Vertical Vise (122854-6), Dust Bag (122852-0), Triangular Rule (762001-3), Socket Wrench (782232-8)

Blade Diameter	10"
Arbor	5/8"
Max. Cutting Capacities:	
at 90° (2-13/16" x 12"), at 45° L/R (2-13/16" x 8-1/2")	
No Load Speed	3,200 RPM
Dimensions (LxWxH)	28-1/4" x 25-1/4" x 26-1/2"
Net Weight	53.1 lbs.
Shipping Weight	66.85 lbs.



LS1016L

10" DUAL SLIDE COMPOUND MITER SAW

Largest Crown Molding Cutting Capacity in its Class

- 10" slide miter saw with the crown molding cutting capacity (6-5/8" vertically-nested) of a 12" saw
- Built-in laser clearly indicates line-of-cut whether blade is turning or not
- Compact design with a patented 4-Steel Rail Sliding System further increases rigidity to produce superior cuts
- Exclusive 6 linear ball bearings engineered to deliver "dead-on" accurate cuts

Model LS1016L Includes: 10" x 5/8" 60T Micro-Polished Miter Saw Blade (A-93675), Vertical Vise (122854-6), Dust Bag (122852-0), Triangular Rule (762001-3), Socket Wrench (782232-8)

Blade Diameter	10"
Arbor	5/8"
Max. Cutting Capacities:	
at 90° (2-13/16" x 12"), at 45° L/R (2-13/16" x 8-1/2")	
No Load Speed	3,200 RPM
Dimensions (LxWxH)	28-1/4" x 25-1/4" x 26-1/2"
Net Weight	53.3 lbs.
Shipping Weight	68.5 lbs.



LS1016LX5

10" DUAL SLIDE COMPOUND MITER SAW

Largest Crown Molding Cutting Capacity in its Class

- 10" slide miter saw with the crown molding cutting capacity (6-5/8" vertically-nested) of a 12" saw
- Built-in laser clearly indicates line-of-cut whether blade is turning or not
- Includes a durable stand for easier job-site portability that features up to 9' material support extensions and adjustable leg supports
- Exclusive 6 linear ball bearings engineered to deliver "dead-on" accurate cuts

Model LS1016LX5 Includes: Jobsite Miter Saw Stand (WST05), 10" x 5/8" 60T Micro-Polished Miter Saw Blade (A-93675), Vertical Vise (122854-6), Dust Bag (122852-0), Triangular Rule (762001-3), Socket Wrench (782232-8)

Blade Diameter	10"
Arbor	5/8"
Max. Cutting Capacities:	
at 90° (2-13/16" x 12"), at 45° L/R (2-13/16" x 8-1/2")	
No Load Speed	3,200 RPM
Dimensions (LxWxH)	28-1/4" x 25-1/4" x 26-1/2"
Net Weight	110.2 lbs.
Shipping Weight	135 lbs.



LS1018

10" DUAL SLIDE COMPOUND MITER SAW

Large Cutting Capacity in a Compact Design and Less Weight

- Powerful 13.0 AMP direct drive motor requires less maintenance and delivers 4,300 RPM
- Meters 0° - 47° left and 0° - 60° right, with positive stops at 0°, 15°, 22.5°, 31.6°, 45° (left and right)
- Linear ball bearing system engineered to deliver "dead-on" accurate cuts
- Less weight (43.7 lbs.) and compact design for job site portability

Model LS1018 Includes: 10" 40T Miter Saw Blade (JM23000176), Triangular Rule for Miter Saws (JM27000328), Vice Assembly, LS1018 (JM23100502), Dust Bag Assembly, LS1018 (JM23100501), Extension Wing, LS1018 (JM23100500), Wrench 13 (782230-2)

Blade Diameter	10"
Arbor	5/8"
Max. Cutting Capacities:	
at 90° (3-5/8" x 12"), at 45° L/R (3-5/8" x 8-1/2")	
No Load Speed	4,300 RPM
Dimensions (LxWxH)	21-1/8" x 32-1/2" x 25"
Net Weight	43.7 lbs.
Shipping Weight	51.7 lbs.

PORTABLE & POWERFUL



NEW XSL02Z

18v X2 LXT® BRUSHLESS 7-1/2" COMPOUND MITER SAW

Powerful BL™ Brushless Motor Delivers 5,700 RPM for Faster Cutting

- Two 18V LXT® Lithium-Ion Batteries deliver the power and performance of a corded miter saw without leaving the 18V LXT® platform
- Automatic Speed Change™ technology adjusts cutting speed and torque during cut for optimum performance
- The BL™ Brushless Motor eliminates carbon brushes, enabling the BL Motor to run cooler and more efficiently for longer life
- Efficient BL™ Brushless motor is electronically controlled to optimize battery energy use for up to 50% longer run time per charge

Model XSL02Z Includes: 7-1/2" 40T C.T. Miter Saw Blade (A-90912); Battery and Charger not included

Blade Diameter	7-1/2"
Arbor	5/8"
Max. Cutting Capacity (Bevel/Miter):	90°/90° (2-1/16" x 11-3/4"), 45°/45° (2-1/16" x 8-3/8")
No Load Speed	5,700 RPM
Battery	2X 18V LXT® Lithium-Ion
Dimensions (LxWxH)	25-3/4" x 17" x 17-1/2"
Net Weight (with battery)	28.9 lbs.
Shipping Weight	38 lbs.

Tool only - battery and charger not included



XSL01 **3.0Ah BATTERY**

18v LXT® 7-1/2" COMPOUND MITER SAW KIT

Large Cutting Capacity up to 2-1/16" and 11-3/4" Crosscuts at 90°

- Powerful Makita-built motor delivers 2,200 RPM
- Weighs only 27.5 lbs. with battery for reduced operator fatigue
- Four steel rail sliding system increases rigidity to produce superior accurate cuts
- Miters 0-47° left and 0-57° right; bevels 0-45° left and 0-5° right

Model XSL01 Includes: (2) 18V LXT® Lithium-Ion 3.0Ah Battery (BL1830), 18V Lithium-Ion Rapid Optimum Charger (DC18RC), 7-1/2" 40T C.T. Miter Saw Blade (A-90912), (2) Extension Wing (322312-4), Vertical Vise (122571-8), Dust Bag (122852-0), Triangular Rule (762001-3), Socket Wrench (782223-9)

Model XSL012 Includes: Tool Only; Battery and Charger not included

Blade Diameter	7-1/2"
Arbor	5/8"
Max. Cutting Capacity (Bevel/Miter):	90°/90° (2-9/16" x 11-3/4"), 45°/45° (1" x 11-3/4")
No Load Speed	2,200 RPM
Battery	18V LXT® Lithium-Ion
Dimensions (LxWxH)	25-3/4" x 17" x 17-7/8"
Net Weight (with battery)	27.5 lbs.
Shipping Weight	44 lbs.



LS0815F

8-1/2" SLIDE COMPOUND MITER SAW

Compact and Lightweight Design for Job Site Portability

- Powerful 10.5 AMP direct drive motor requires less maintenance and delivers 5,000 RPM
- Cuts up to 12" at 90° and 8-1/2" at 45°
- Miters 0°- 50° left and 0°- 60° right, with positive stops at 0°, 15°, 22.5°, 31.6°, 45° (right or left)
- Compact and lightweight (31.1 lbs.) for job site portability

Model LS0815F Includes: 8-1/2" 48T Carbide-Tipped Miter Saw Blade (A-95934), Triangle Rule for Miter Saws (JM27000328), Vertical Vise, LS0815F (JM23510009), Dust Bag, LS0815F (JM23510010), Box Wrench, LS0815F (782230-2), (2) Extension Wing (JM23000127)

Blade Diameter	8-1/2"
Arbor	5/8"
Max. Cutting Capacities:	at 90° (2-9/16" x 12"), at 45° L/R (2-9/16" x 8-1/2")
No Load Speed	5,000 RPM
Dimensions (LxWxH)	29-3/4" x 17-3/4" x 19-1/4"
Net Weight	31.1 lbs.
Shipping Weight	41.8 lbs.



LS1221

12" COMPOUND MITER SAW

Consistently Precise Cutting Performance

- Large cutting capacity (3-7/8" x 6" at 90°)
- 4-1/2" tall pivoting fence for cutting up to 5-1/2" crown molding
- Powerful 15 AMP direct drive motor delivers 4,000 RPM for smooth performance
- Positive stops at 9 settings; 15°, 22.5°, 31.6°, 45° right or left and 0°
- Horizontal D-handle design for easy and comfortable operation
- Electric brake for maximum productivity

Model LS1221 Includes: 12" x 1" 40T Micro-Polished Miter Saw Blade (A-93706), Vertical Vise (122540-9), Extension Wing (323726-0), Socket Wrench (782232-8), Dust Bag (122852-0)

Blade Diameter	12"
Arbor	5/8"
Max. Cutting Capacities:	at 90° (3-7/8" x 6"), at 45° L/R (2-3/4" x 5-7/8")
No Load Speed	4,000 RPM
Dimensions (LxWxH)	24" x 26-1/2" x 23-7/8"
Net Weight	37 lbs.
Shipping Weight	50 lbs.



LS1040

10" COMPOUND MITER SAW

Pivoting Fence for Supporting Larger Material

- Powerful 15 AMP direct drive motor for improved performance
- Dual post compound pivoting arm; bevel cuts up to 45° to the left
- Weighs only 24.2 lbs. for easy portability
- Positive stops at 9 settings: 15°, 22.5°, 30°, 45° right or left & 0° (90° cuts)
- Miter cuts 0 - 45° left and 0 - 52° right

Model LS1040 Includes: 10" x 5/8" 40T Micro-Polished Miter Saw Blade (A-93669), Dust Bag (122852-0), Triangular Rule (762001-3), Vertical Vise (122536-0), Socket Wrench (782232-8)

Blade Diameter	10"
Arbor	5/8"
Max. Cutting Capacities:	at 90° (2-3/4" x 5-1/8"), at 45° L/R (1-3/8" x 3-5/8")
No Load Speed	4,600 RPM
Dimensions (LxWxH)	20-7/8" x 18-3/4" x 21"
Net Weight	27.3 lbs.
Shipping Weight	28 lbs.

Jobsite Miter Saw Stands

Fits All Makita® Miter Saws



WST05

Large Solid Rubber Wheels for Easier Jobsite Portability

- Material support extensions (extend 9") with adjustable leg supports for increased cutting accuracy
- Spring-loaded mechanism engineered for quick and easy jobsite set up
- Durable duty aluminum feed roller and adjustable material stop engineered for increased speed on repetitive cuts
- Compact design (46" folded) for convenient transportation to and from the jobsite, and easy vertical or horizontal storage
- 2-Position adjustable stand provides additional height set up for increased comfort
- Adjustable non-marring rubberized feet provide additional support when leveling stand on uneven surfaces

Material Support Extensions	9"
Spring Loading Mechanism	Yes
In-Feed Roller	Yes
Material Stop	Yes
Folded Dimensions (W)	46"
Dimensions (LxWxH)	46" x 19-3/4" x 15-3/4"
Net Weight	58.0 lbs.
Shipping Weight	66.0 lbs.



195083-4

Ideal for Jobsite Use

- Large platform base for additional work space
- 5-position adjustable stand fits different height requirements
- Material support extensions (extends 9") with feed roller deliver enhanced convenience and work speed
- Solid rubber 12" wheels for easy portability, job to job
- Spring loaded mechanism for quick and easy setups



Material Support Extensions	9"
Spring Loading Mechanism	Yes
In-Feed Roller	Yes
Material Stop	Yes
Folded Dimensions (W)	50-1/2"
Dimensions (LxWxH)	50-1/2" x 21-1/2" x 15-3/4"
Net Weight	79.0 lbs.
Shipping Weight	90.7 lbs.

Miter Saw Blades

Premium Ultra-Coated

Alternate Top ATAF
Alternate Face
ATAF (Alternate Top and Alternating Face) tooth design for ultra precision cutting



Japanese ultra-thin kerf carbide-tipped design provide smoother cuts with less drag on the motor and minimal material loss



Fully hardened and expertly hand-tensioned steel saw plates for true cuts



Resin Bond Filled Laser Cut Slots

ULTRA-COATED

Ultra-coated blades provide reduced pitch build-up



Ultra-coated blades feature resin bond filled laser cut slots for quiet and smooth cutting

Micro-Polished

Alternate Top ATAF
Alternate Face
ATAF (Alternate Top and Alternating Face) tooth design for ultra precision cutting



Japanese ultra-thin kerf carbide-tipped design provide smoother cuts with less drag on the motor and minimal material loss

Micro-grain carbide-teeth are honed with up to 600 grit for a mirror finish



Fully hardened and expertly hand-tensioned steel saw plates for true cuts

Additional Miter Saw Blades See pg. 117

Miter Saw Workstation



Description	Model	Part #
1 Extension Wing	LS1013F/FL, LS1214F/FL	322932-4
	LS1036, LS1011	192118-2
	LS0714, LS1040	322312-4
	LS1221	323726-0
	LS1016/L/LX5, LS1216L/LX4	325673-1 ¹
LS0815F	JM23000127	
2 Right Sub-Fence	LS1013F/FL, LS1214F/FL	153898-5
	LS1013F/FL, LS1214F/FL	192628-9
3 Crown Molding Stopper Set	LS1013F/FL, LS1214F/FL	192622-1
	LS1016/L/LX5, LS1221	192669-5
	LS1216L/LX4	195253-5
4 Vertical Vise	LS1040	122536-0
	LS1013F/FL	122538-6
	LS1221	192672-6
	LS1214F/FL	122540-9
	LS0714	122571-8
	LS1016/L/LX5, LS1216L/LX4	122854-6

Description	Model	Part #
5 Horizontal Vise	LS1013F/FL, LS1214F/FL, LS1221	122470-4
	LS1040, LS0714	122567-9
	LS1016/L/LX5, LS1216L/LX4	122930-6
6 Directional Elbow	LS1040, LS1013F/FL, LS1221, LS1214F/FL	416368-8
7 Extension Rod 1/2" x 83"	LS1040, LS1221, LS1214F/FL	256812-1
8 Extension Rod Holder	LS1040	122446-1
9 Repetitive Cut Set Plate	LS1040	122472-0
	LS0714, LS1221,	
10 Dust Box	LS1016/L/LX5, LS1216L/LX4, LS0714, LXSLO1	194175-6

¹ Use with thumbscrew Part # 251889-1



2705

10" TABLE SAW Precision Machined Table Top for Accurate Cuts

- Powerful 15 AMP motor delivers 4,800 RPM for improved performance
- Large cutting capacity (3-9/16" at 90° and 2-1/2" at 45°) can rip 4x material in one pass; can use up to a 13/16" dado blade
- Right extension table allows for greater cutting capacity with the capability to rip 4x8 sheets of plywood
- Extended capacity with up to 25" ripping
- "Tool-less" modular blade guard system with an adjustable riving knife/spreader

Model 2705 Includes: 10" 32T Carbide-Tipped Table Saw Blade (A-94948), Rip Fence (122740-1), Miter Gauge (122838-4), Push Stick (416772-1), Spanner Wrench (781038-1), Wrench (782024-5), Wrench 5 (783224-8)

Blade Diameter	10"
Arbor	5/8"
Max. Cutting Capacities:	at 90° (3-5/8"), at 45° (2-1/2")
No Load Speed	4,800 RPM
Table Size (WxL)	24-5/8" x 22-1/4"
Net Weight	65.5 lbs.
Shipping Weight	82 lbs.



2705X1

10" CONTRACTOR TABLE SAW WITH STAND Includes Stand - Precision Machined Table Top for Accurate Cuts

- Powerful 15.0 AMP motor delivers 4,800 RPM for improved performance
- Large cutting capacity (3-9/16" at 90° and 2-1/2" at 45°); rips 4x material in one pass
- Large 25" ripping capacity for cutting plywood/sheet material
- Easy to read scale with magnifying glass for increased accuracy
- Spring loaded mechanism for quick and easy set up

Model 2705X1 Includes: 10" 32T Carbide-Tipped Table Saw Blade (A-94948), Rip Fence (122740-1), Miter Gauge (122838-4), Push Stick (416772-1), Spanner Wrench (781038-1), Wrench (782024-5), Hex Wrench (783203-8), Portable Table Saw Stand (194093-8)

Blade Diameter	10"
Arbor	5/8"
Max. Cutting Capacities:	at 90° (3-5/8"), at 45° (2-1/2")
No Load Speed	4,800 RPM
Table Size (WxL)	24-5/8" x 22-1/4"
Net Weight	114.7 lbs.
Shipping Weight	171 lbs.

Portable Table Saw Stand

Part No. 194093-8



Rubberized Handle
Heavy-Duty Design

Large Wheels

Table Saw Accessories

Description	Models	Part #
Porta-Table	2703	122731-A
Table Saw Stand	2703	193920-6
Blade Guard System	2705/X1	122820-3
Outfeed Table Set	2704, 2705/X1	194087-3
Dado Flange Set	2703, 2704	192693-8
Dado Head Insert	2703, 2704, 2705/X1	317061-6 317934-3
Push Stick	2703, 2704, 2705/X1	416772-1
Push Block	2703, 2704, 2705/X1	155508-0
Miter Gauge	2703, 2704, 2705/X1	122555-6 122838-4



Intern-Lok

2012NB

12" PORTABLE PLANER Automated Head Clamp Eliminates Snipe

- Compact with less weight for easy transporting to the jobsite
- Engineered for faster, easier blade changes
- Low noise (83dB) for operator comfort
- 4-post design and diagonal cross supports for stability
- Large and easy-to-operate on/off paddle switch
- Fully adjustable depth stop for repeat cuts

Model 2012NB Includes: 12" Double Edged Planer Blade, 2/pk (793346-8), Magnetic Holder (762014-4), Blade Wrench (783208-8), Key (415715-0)

Cutting Capacities:	
Width (12"), Depth (1/8"), Thickness (6-3/32")	
No. of Knives	2
Table Size (WxL)	12" x 30-3/8"
AMPS	15
Dimensions (LxWxH)	30-3/8" x 19-1/64" x 15-25/32"
Net Weight	61.9 lbs.
Shipping Weight	67.6 lbs.

WOODWORKING

1-1/4 HP*
Compact Router Kit
RT0701CX3
*Maximum horsepower



MULTI-TOOLS



pg. 76

ROUTERS / LAMINATE TRIMMERS



pgs. 76-77

SANDERS / BELT SANDERS



pgs. 78-80

PLANERS



pgs. 80-81

PLATE JOINERS



pg. 81

ACCESSORIES



pgs. 120-124

SPEED & EFFICIENCY



14 INCLUDED
Accessories

1-1/4" Plunge Blade
A-95255

Adapter
313249-6

Adapter
196271-6

Sanding Pad
A-95423

Sandpaper
10 Pc. Assortment

TM3010CX1

MULTI-TOOL KIT "Tool-less" Clamp System for Fast Accessory Installation

- Powerful 3.0 AMP motor with soft start feature for smooth start-ups and improved performance for fast cutting, sanding, scraping and grout removal
- Variable speed control dial (6,000-20,000 OPM) enables user to match the speed to the application
- Electronic speed control maintains constant speed under load for smoother, higher-quality work
- Precision engineered for reduced vibration (6.5m/s²) and low noise 80dB(A)
- 3.2° oscillation angle engineered for faster cutting and sanding

Model TM3010CX1 Includes: 1-1/4" Plunge Blade (BiM) (A-95255), Sanding Pad, Multi-Tool, TM3000C, LXMT (A-95423), (5) 120 Grit Sandpaper (A-95532-1), (5) 180 Grit Sandpaper (A-95548-1), Multi-Tool Adapter (313248-8), Multi-Tool Adapter (313249-6), Multi-Tool Adapter (313248-8), Multi-Tool Adapter (313249-6), Accessory Case, Tool Case

Oscillations Per Minute	6,000 - 20,000 OPM
Oscillation Angle	3.2°
AMPS	3
Overall Length	11-1/8"
Net Weight	3.5 lbs.
Shipping Weight	8.8 lbs.

Additional Multi-Tool Accessories

2" Scraper

A-95342



3" Scraping Plate

A-95401



1-1/4" Plunge Blade

A-95277



3-1/4" Round Saw Blade

A-95168



3-1/4" Segmented Saw Blade

A-95227



3-1/4" Grout Removal Blade

A-95386



(10 per/pkg)

Sandpaper



Description	Part #
Assortment	A-95853
180 Grit	A-95548
150 Grit	A-95750
120 Grit	A-95532
100 Grit	A-95744
80 Grit	A-95526

Additional Multi-Tool Accessories See pg. 123



18v LXT® MULTI-TOOL KIT "Tool-less" Clamp System for Fast Accessory Installation

- 18V LXT® Lithium-Ion battery provides up to 20 minutes of continuous run time
- Variable speed control dial (6,000-20,000 OPM) enables user to match the speed to the application
- 3.2° oscillation angle engineered for faster, more aggressive cutting and sanding
- Large on/off slide switch with lock-on button for operator convenience

Model XMT035 Includes: (2) 18V LXT® Lithium-Ion 3.0Ah Battery (BL1830), 18V Lithium-Ion Rapid Optimum Charger (DC18RC), 1-1/4" Plunge Blade (BiM) (A-95255), Multi-Tool Adapter (313249-6), Multi-Tool Adapter (313248-8), Tool Bag

Model XMT03Z Includes: Tool Only, Battery and Charger not included

Oscillations Per Minute	6,000 - 20,000 OPM
Oscillation Angle	3.2°
Battery	18V LXT® Lithium-Ion
Overall Length	13-3/8"
Net Weight (with battery)	4.9 lbs.
Shipping Weight	14.1 lbs.



RP2301FC

3-1/4 HP* PLUNGE ROUTER Delivers Power and Precision

- Powerful 15 AMP motor delivers 9,000 - 22,000 RPM for smooth routing
- Electronic speed control maintains constant speed under load
- Variable speed control dial enables user to match the speed to the application
- Soft start feature for smooth start-ups
- Electric brake for maximum productivity
- 0" - 2-3/4" plunge depth capacity for easy penetration in work piece

Model RP2301FC Includes: 1/2" Collet (763622-4), 1/4" Collet (763803-0), Extend Depth Adjustment Knob (158980-5), Spanner Wrench (781030-7)

Collet Capacity	1/2", 1/4"
Plunge Capacity	2-3/4"
No Load Speed (variable speed)	9,000 - 22,000 RPM
AMPS	15
Maximum Horsepower	3-1/4 HP
Overall Length	12-1/4"
Net Weight	13.4 lbs.
Shipping Weight	16.4 lbs.



RP1800

3-1/4 HP* PLUNGE ROUTER Deep 2-3/4" Depth Capacity Delivers Performance

- Powerful 15 AMP motor delivers up to 22,000 RPM for smooth routing
- 0" - 2-3/4" plunge depth capacity for easy penetration in work piece
- Linear ball bearings for smooth plunge action and superior performance
- Quick release plunge depth adjustment with micro control along with 3 preset depth stops for added precision
- Oversized ball bearing construction for longer tool life

Model RP1800 Includes: 1/2" Collet (763622-4), 1/4" Collet (763803-0), Extend Depth Adjustment Knob (158980-5), Spanner Wrench (781030-7)

Collet Capacity	1/2", 1/4"
Plunge Capacity	2-3/4"
No Load Speed	22,000 RPM
AMPS	15
Maximum Horsepower	3-1/4 HP
Overall Length	12-1/4"
Net Weight	13.4 lbs.
Shipping Weight	16.4 lbs.



RP0900K

1-1/4 HP* PLUNGE ROUTER Powerful 8 AMP Motor Delivers 27,000 RPM

- 0" - 1-3/8" plunge depth capacity for easy penetration into work piece
- Plunge depth adjustment lever with 3 preset depth stops for precision
- Oversized ball bearing construction for longer tool life
- Durable flat top design for added convenience when changing bits
- Rubberized contoured handles with built-in switch for better fit & control
- Easy-to-read depth scales

Model RP0900K Includes: 1/4" Collet (763637-1), Straight Guide (164834-6), Spanner Wrench (781006-4), Spanner Wrench (781011-1), Tool Case

Collet	1/4"
Plunge Capacity	1-3/8"
No Load Speed	27,000 RPM
AMPS	8
Maximum Horsepower	1-1/4 HP
Overall Length	8-1/2"
Net Weight	6 lbs.
Shipping Weight	5.52 lbs.



RF1101KIT2

2-1/4 HP* ROUTER KIT, WITH PLUNGE BASE Deluxe Kit Includes the Most Popular Accessories

- Powerful 11 AMP motor with variable speed control dial
- Electronic speed control with soft start feature
- Rugged aluminum motor housing with small 3-1/4" diameter
- Cam-lock for fast and easy depth adjustment and removal of motor
- Conveniently located plunge lock lever for efficient operation

Model RF1101KIT2 Includes: 2-1/4 HP* Router (RF1101), Plunge Base (193457-3), 1/2" Collet (763643-6), 1/4" Collet with Nut (193214-9), 2-1/2" Clear Sub Base (193155-9), (2) Wrench 27 (193234-3), Spanner Wrench (781213-9), Hex Wrench (783202-0), Tool Case

Collet Capacity	1/2", 1/4"
Plunge Capacity	2-9/32"
No Load Speed (variable speed)	8,000 - 24,000 RPM
AMPS	11
Maximum Horsepower	2-1/4 HP
Overall Length	8-3/4"
Net Weight	7.2 lbs.
Shipping Weight	20 lbs.

*Maximum horsepower



RF1101

2-1/4 HP* ROUTER
Quietest and Lowest Vibration Router in its Class

- Variable speed control dial to match the speed to the application
- Electronic speed control maintains constant speed under load
- Soft start feature for smooth start-ups
- Rugged aluminum motor housing with small 3-1/4" diameter
- Sub-base accepts industry standard template guides
- Durable flat top for stability when changing bits

Model RF1101 Includes: 1/2" Collet (763643-6), 1/4" Collet with Nut (193214-9), Wrench 27 (193234-3)

Collet Capacity	1/2", 1/4"
No Load Speed (variable speed)	8,000 - 24,000 RPM
AMPS	11
Maximum Horsepower	2-1/4 HP
Overall Length	8-3/4"
Net Weight	7.2 lbs.
Shipping Weight	10 lbs.

RD1101

2-1/4 HP* ROUTER
Variable Speed (8,000-24,000 RPM)

- Electronic speed control maintains constant speed under load
- Soft start feature for smooth start-ups
- Rugged aluminum motor housing with small 3-1/4" diameter
- Sub-base accepts industry standard template guides
- Industrial cam-lock for fast and easy depth adjustment and removal of motor

Model RD1101 Includes: 1/4" Collet with Nut (193214-9), 1/2" Collet (763643-6), Wrench 27 (193234-3)

Collet Capacity	1/2", 1/4"
No Load Speed (variable speed)	8,000 - 24,000 RPM
AMPS	11
Maximum Horsepower	2-1/4 HP
Overall Length	8-3/4"
Net Weight	7.9 lbs.
Shipping Weight	10.9 lbs.

ADDED VERSATILITY



RT0701CX3

1-1/4 HP* COMPACT ROUTER KIT
Powerful 1-1/4 HP* Motor for Improved Performance

- Variable speed control dial (10,000 - 30,000 RPM) to match the speed to the application
- Smooth rack-and-pinion fine depth adjustment system for more precise settings
- Accepts industry standard template guides
- Ideal for routing small profiles, dovetailing, door hinges and more
- 0" - 1-3/8" plunge depth capacity for easy penetration into workpiece
- Tilt base for routing at different angles (-30° to 45°)

Model RT0701CX3 Includes: 1/4" Collet (763637-1), Plunge Base (195563-0), Tilt Base (195561-4), Offset Base (195562-2), Trimmer Guide (122703-7), Dust Nozzle (194733-8), Straight Guide (164834-6), Spanner Wrench (781039-9), Spanner Wrench (781011-1), Tool Bag

Collet	1/4"
Plunge Capacity	1-3/8"
No Load Speed (variable speed)	10,000 - 30,000 RPM
AMPS	6.5
Maximum Horsepower	1-1/4 HP
Overall Length	7-7/8"
Net Weight	3.9 lbs.
Shipping Weight	19.8 lbs.



RT0701CX7

1-1/4 HP* COMPACT ROUTER KIT
Powerful 1-1/4 HP* Motor Delivers Improved Performance

- Variable speed control dial (10,000 - 30,000 RPM) enables user to match the speed to the application
- Smooth rack-and-pinion fine depth adjustment system for more precise settings
- Slim and ergonomically designed body for increased comfort and control
- Cam lock system for easy depth adjustments
- Kit includes fixed and plunge bases

Model RT0701CX7 Includes: 1/4" Collet (763637-1), Plunge Base (195563-0), Straight Guide (164834-6), Spanner Wrench (781039-9), Spanner Wrench (781011-1)

Collet	1/4"
No Load Speed (variable speed)	10,000 - 30,000 RPM
AMPS	6.5
Maximum Horsepower	1-1/4 HP
Overall Length	7-7/8"
Net Weight	3.9 lbs.
Shipping Weight	10.5 lbs.

RT0701C

1-1/4 HP* COMPACT ROUTER
Powerful 1-1/4 HP* Motor Delivers Performance and Accuracy

- Variable speed control dial (10,000 - 30,000 RPM) to match the speed to the application
- Smooth rack-and-pinion fine depth adjustment system for more precise settings
- Slim and ergonomically designed body for increased comfort and control
- Accepts industry standard template guides
- Cam lock system for easy depth adjustments
- Electronic speed control maintains constant speed under load

Model RT0701C Includes: 1/4" Collet (763637-1), Straight Guide (122965-7), Spanner Wrench (781039-9), Spanner Wrench (781011-1)

Collet	1/4"
No Load Speed (variable speed)	10,000 - 30,000 RPM
AMPS	6.5
Maximum Horsepower	1-1/4 HP
Overall Length	7-7/8"
Net Weight	3.9 lbs.
Shipping Weight	6.3 lbs.

Compact Router Accessories



Plunge Base Assembly

Model	Part #
-------	--------

RT0700C, RT0701C, RT0700CX3, RT0701CX7



Tilt Base

Model	Part #
-------	--------

RT0700C, RT0701C, RT0700CX3, RT0701CX7



Offset Base

Model	Part #
-------	--------

RT0700C, RT0701C, RT0700CX3, RT0701CX7



Fixed Base Handles

Model	Part #
-------	--------

RT0700C, RT0701C, RT0700CX3, RT0701CX7



Dust Nozzle

Model	Part #
-------	--------

RP0900K, RT0700CX3, RT0701CX3, RT0701CX7



Trimmer Guide

Model	Part #
-------	--------

RT0700C, RT0701C/CX3/CX7, RT0700CX3



3709

1/4" FIXED BASE LAMINATE TRIMMER
Super Smooth Rack-and-Pinion Depth Adjustment

- 4.0 AMP motor delivers 30,000 RPM for smooth trimming and light routing applications
- Top-mounted power cord stays out of the way for easier operation
- Transparent base for a clear view of the trimming edge
- Slim design with rubberized grip for comfort and control
- Smooth rack-and-pinion fine depth adjustment

Model 3709 Includes: 1/4" Collet (763663-0), Template Guide (343577-5), Spanner Wrench (781036-5), Spanner Wrench (781037-3), Straight Bit 6E (732338-9), Chip Deflector (418647-0), Trimmer Guide (122703-7)

Collet	1/4"
No Load Speed	30,000 RPM
AMPS	4
Overall Length	7-7/8"
Net Weight	3.3 lbs.
Shipping Weight	5.66 lbs.

*Maximum horsepower

OFF ROAD



ROCKSTAR ENERGY DRINK
Makita

Rob MacCachren is a legend in the off road community. With over 200 victories in off road and a place in the Off Road Hall of Fame, Rob Mac has earned the respect and love of fans around the world. Rob races his 900 horsepower Pro 4 and Pro 2 in his Rockstar® Makita® Ford® short course trucks in the Lucas Oil Off-Road Racing Series (LOORRS).

The team is also the team to beat in the grueling Score®-International Baja Races while racing the exciting Trophy Truck class. Rob has back-to-back wins in the Baja 1000 mile race over the last few years.



SNOCROSS



WARNERT
Makita

Warnert Racing is a "superteam" in professional snowmobile racing with multiple championships. The Makita® NSK® Ski-Doo® Factory Team races in the International Series of Champions (ISOC). The team races in both the Pro Open and Pro Lite classes and led by the young, crowd-favorite, Elias Ishoel #200.

Elias is known for taking the fastest lines as well as making the jumps into "triple" where they are technically a "double." Makita® is also the Official Power Tool of ISOC.



B05030K Shown

B05030 / B05030K

5" RANDOM ORBIT SANDER Rubberized Grip for Increased Comfort

- Large 1/8" random orbit action for fast and super smooth sanding
- Pad control system for controlled pad speed up on start-up
- Efficient through-the-pad dust collection system
- Dust-sealed switch minimizes contamination
- Uses 5" (8-hole) hook-and-loop abrasive paper

Model B05030 Includes: Dust Bag (166078-4)

Model B05030K Includes: Same as B05030 plus Tool Case

Pad Size (round)	4-13/16"
Abrasive Disc Size	5"
Orbits Per Minute	12,000 OPM
Orbit Diameter	1/8"
AMPS	3
Vibration (m/s ²)	4.5
Dimensions (LxWxH)	6" x 4-7/8" x 6"
Net Weight	2.9 lbs.
Shipping Weight:	B05030 (3.75 lbs.), B05030K (6 lbs.)



B05031K

5" RANDOM ORBIT SANDER, WITH CASE

- Large 1/8" random orbit action for fast and super smooth sanding
- Pad control system for controlled pad speed upon start-up
- Efficient through-the-pad dust collection system
- Dust-sealed switch minimizes contamination
- Variable speed control dial (4,000 - 12,000 OPM) to match the speed to the application
- Uses quick-change 5" (8-Hole) hook-and-loop paper

Model B05031K Includes: Dust Bag (166078-4), Tool Case

Pad Size (round)	4-13/16"
Abrasive Disc Size	5"
Orbits Per Minute (variable speed)	4,000 - 12,000 OPM
Orbit Diameter	1/8"
AMPS	3
Vibration (m/s ²)	4
Dimensions (LxWxH)	6" x 4-7/8" x 6"
Net Weight	3 lbs.
Shipping Weight	7 lbs.



B05041K Shown

B05041 / B05041K

5" RANDOM ORBIT SANDER, WITH VARIABLE SPEED

- Smooth and fast sanding with 3.0 AMP motor
- Variable speed control dial (4,000-12,000 OPM) enables user to match the sanding speed to the application
- Ergonomic rubberized palm grip and handle for improved operator comfort and control
- Adjustable front handle allows for sanding in corners and confined areas
- Uses quick-change 5" (8-hole) hook-and-loop abrasive paper

Model B05041 Includes: Dust Bag (166078-4)

Model B05041K Includes: Same as B05041 plus Tool Case

Pad Size (round)	4-13/16"
Abrasive Disc Size	5"
Orbits Per Minute (variable speed)	4,000 - 12,000 OPM
Orbit Diameter	1/8"
AMPS	3
Vibration (m/s ²)	3.5
Dimensions (LxWxH)	10-7/8" x 4-7/8" x 6"
Net Weight	3.5 lbs.
Shipping Weight:	B05041 (4.1 lbs.), B05041K (6.3 lbs.)

#1 START TO FINISH



ACCURACY

2-mode switch for "random orbit" and "random orbit with forced rotation"

NEW B06050J

6" RANDOM ORBIT SANDER Fine or Fast Finish with 2-Mode Selection

- Convenient 2-mode switch for "random orbit" and "random orbit with forced rotation" action
- Variable speed control dial (1,600 - 6,800 OPM) to match the speed to the application
- Ergonomically designed barrel grip and side handle for increased comfort
- 7/32" orbit diameter provides a swirl-free finish
- "Tool-less" backing pad change enables quick pad change to meet application
- Efficient through-the-pad dust collection system with built-in dust port for a cleaner work environment

Model B06050J Includes: Plastic Carrying Case, Pad Protector, Pad, Side Handle, Removable Dust Nozzle, Abrasive Paper

Pad Size (round)	6"
Abrasive Disc Size	6"
Orbits Per Minute (variable speed)	1,600 - 6,800 OPM
Orbit Diameter	7/32"
AMPS	6.6
Vibration (m/s ²)	5
Dimensions (LxWxH)	13" x 6-1/8" x 5-3/4"
Net Weight	5.7 lbs.
Shipping Weight	12.4 lbs.



B06030

6" RANDOM ORBIT SANDER 30% Less Vibration than the Nearest Competitor

- Variable speed control dial (4,000-10,000 OPM) enables user to match the sanding speed to the application
- Efficient through-the-pad dust collection system with dust bag for a cleaner work environment
- Ergonomic rubberized rear handle reduces vibration for operator comfort
- 1/8" orbit diameter provides a swirl-free finish
- Utilizes 6" hook-and-loop abrasive discs for fast and easy installation

Model B06030 Includes: 6" Round Abrasive Disc, Hook & Loop, 120 Grit (794610-0-1), Hex Wrench (783203-8), Dust Bag (151517-7), Dust Nozzle (151518-5), Wrench Holder (410047-0), Rubber Pad (193286-4)

Pad Size (round)	6"
Abrasive Disc Size	6"
Orbits Per Minute (variable speed)	4,000 - 10,000 OPM
Orbit Diameter	1/8"
AMPS	2.7
Vibration (m/s ²)	4
Dimensions (LxWxH)	12-1/8" x 5-7/8" x 7-1/8"
Net Weight	5.2 lbs.
Shipping Weight	6.9 lbs.



Z
ZERO VIBRATION
XOB01Z



B04556K
Shown



B03710



B04900V



XOB01

18v LXT® 5" RANDOM ORBIT SANDER KIT
Corded Performance without the Cord

- Three speed settings (7,000/9,500/11,000 OPM) engineered for fast material removal
- Up to 40 minutes (low speed) and 20 minutes (high speed) of run time on a single charge
- Large 1/8" random orbit action engineered for fast sanding and swirl-free finish
- One-touch electronic speed control switch provides fast, medium and low settings
- Ergonomically designed body and grip for increased operator comfort

Model XOB01 Includes: (2) 18V LXT® Lithium-Ion 3.0Ah Battery (BL1830), 18V Lithium-Ion Rapid Optimum Charger (DC18RC), Tool Bag

Model XOB01Z Includes: Tool Only; Battery and Charger not included

Pad Size (round)	4-7/8"
Abrasive Disc Size	5"
Orbits Per Minute (3 speed)	7,000, 9,500, 11,000 OPM
Orbit Diameter	1/8"
Battery	18V LXT® Lithium-Ion
Overall Length	6-7/8"
Net Weight (with battery)	3.6 lbs.
Shipping Weight	12 lbs.

B04556 / B04556K

FINISHING SANDER
14,000 OPM for Fast and Smooth Finish Sanding

- Precision engineered all-ball-bearing construction for reduced vibration and noise
- Contoured, rubberized palm grip design for operator comfort
- Large clamping lever for quick and easy paper installation
- Efficient through-the-pad dust collection system
- Conveniently located on/off switch for easy one-handed operation

Model B04556 Includes: 4-1/2" x 5-1/2" Abrasive Paper, 60 Grit (742509-3-1), 4-1/2" x 5-1/2" Abrasive Paper, 100 Grit (742510-8-1), 4-1/2" x 5-1/2" Abrasive Paper, 150 Grit (742511-6-1), Dust Bag (166078-4), Punch Plate (450066-4)

Model B04556K Includes: Same as B04556 plus Tool Case

Pad Size	4-1/2" x 4"
Abrasive Paper Size	4-1/2" x 5-1/2"
Orbits Per Minute	14,000 OPM
AMPS	2
Vibration (m/s ²)	4
Dimensions (LxWxH)	5-1/8" x 4-3/8" x 5-9/16"
Net Weight	2.5 lbs.
Shipping Weight:	B04556 (3.7 lbs.), B04556K (7.15 lbs.)

1/3 SHEET FINISHING SANDER
Lower Vibration and Smooth Finish

- Ergonomic rubberized grip and handle designed for better fit and added comfort
- 11,000 OPM for Increased Efficiency and Smooth Finish Sanding
- Efficient through-the-pad dust collection system for a cleaner work environment
- Built-in counterbalance system engineered to reduce vibration
- Large rubberized clamping lever for quick paper installation

Model B03710 Includes: 1/3 Sheet Abrasive Paper, Hook & Loop, 120 Grit (794568-3-1), Dust Bag (140115-2), Punch Plate (451271-6)

Pad Size	3-5/8" x 7-1/4"
Abrasive Paper Size	3-5/8" x 9"
Orbits Per Minute	11,000 OPM
AMPS	1.7
Vibration (m/s ²)	3.5
Overall Length	10"
Net Weight	3.5 lbs.
Shipping Weight	4.9 lbs.

1/2 SHEET FINISHING SANDER
Through-the-Pad Dust Collection System

- Uses commonly available 4-1/2" x 9" hook-and-loop or 4-1/2" x 11" half sheet abrasive paper
- Efficient through-the-pad dust collection system for a cleaner work environment
- Minimized vibration and contoured grips for added comfort
- Large trigger switch for easier operation
- Ideal for cabinet workers, boat builders and more

Model B04900V Includes: Dust Bag and Holder Assembly (193525-2), Paper Dust Bag, 5/pk (193526-0), Abrasive Paper 3120 (A-14093)

Pad Size	4-1/2" x 9"
Abrasive Paper Size	4-1/2" x 11"
Orbits Per Minute (variable speed)	4,000 - 10,000 OPM
AMPS	2.9
Vibration (m/s ²)	5
Overall Length	11-3/8"
Net Weight	6 lbs.
Shipping Weight	8.8 lbs.

Sander Accessories

Hook & Loop Backing Pad
Use with Hook & Loop abrasive paper



Type	Model	Part #
5" Round Flat Sanding	B05030/K, B05031K, B05041/K	743081-8, 743022-A
4-1/2" x 9"	B04900V	193522-8

Pressure Sensitive Pad
Use with Pressure Sensitive Abrasive Paper



Type	Model	Part #
5" round	B04530	743031-3
6" round		743032-1
4" x 4-3/8"		743030-5
5" round	B05030/K, B05031K, B05041/K	743056-7

4-3/8" x 4" Backing Pad



Type	Model	Part #
Finishing	B04556K	158324-9

6" Hook & Loop Rubber Backing Pad



Type	Model	Part #
General Purpose	B06030,	A-91207
Flat Sanding	B06040	A-91198



9032

3/8" x 21" BELT SANDER
Compact Design for Sanding in Close Quarters

- Variable speed control dial (980 - 5,600 ft./min.) to match the speed to the application
- Adjustable sanding arm pivots 100° for hard-to-reach areas
- Easily adjustable belt tracking with a turn of the knob
- Compact design with low weight (3.5 lbs.) and great balance for sanding in close quarters
- 3 different size arm assemblies and belts are available (1/4", 3/8", 1/2") for increased versatility

Model 9032 Includes: (2) 3/8" x 21" Abrasive Belt, 80 Grit (A-34469-1), 3/8" Arm Assembly (125158-5)

Belt Size	3/8" x 21"
Belt Speed (variable speed)	980 - 5,600 ft./min.
AMPS	4.4
Overall Length	16-1/2"
Net Weight	3.5 lbs.
Shipping Weight	4.4 lbs.



9031

1-1/8" x 21" BELT SANDER
Variable Speed Control Dial

- Versatile for use on wood, metal and fiberglass materials
- Ideal for woodworkers, artists, glaziers, welders, prefinished cabinet installers and finish carpenters
- Compact with less weight (4.6 lbs.) for use in close quarters
- Ball bearing construction for longer tool life
- Narrow belt and exposed front pulley for use on irregular shapes
- Multi-position side handle for easy and comfortable operation

Model 9031 Includes: (2) 1-1/8" x 21" Abrasive Belt, 40 Grit (742301-7-1), (2) 1-1/8" x 21" Abrasive Belt, 60 Grit (742302-5-1), (2) 1-1/8" x 21" Abrasive Belt, 80 Grit (742303-3-1), (2) 1-1/8" x 21" Abrasive Belt, 100 Grit (742304-1-1), (2) 1-1/8" x 21" Abrasive Belt, 120 Grit (742305-9-1)

Belt Size	1-1/8" x 21"
Belt Speed (variable speed)	656 - 3,280 ft./min.
AMPS	5
Overall Length	15"
Net Weight	4.6 lbs.
Shipping Weight	6.32 lbs.



9903

3" x 21" BELT SANDER
Powerful 8.8 AMP Motor; Only 85dB

- Variable speed control dial (690 - 1,440 ft./min.) to match the speed to the application
- Auto-tracking belt system tracks belt without adjustment
- Innovative design for sanding flush to wall with nose and side of sander
- Front grip design for comfortable operation
- 3" wide belt with a speed of 1,440 ft./min. for fast material removal
- Dust bag for a cleaner work environment

Model 9903 Includes: 3" x 21" Abrasive Belt, 80 Grit (742308-3-1), Dust Bag (122591-2)

Belt Size	3" x 21"
Belt Speed (variable speed)	690 - 1,440 ft./min.
AMPS	8.8
Overall Length	11-5/8"
Net Weight	9.5 lbs.
Shipping Weight	11.8 lbs.

OFFICIAL POWER TOOL OF THE MEXICAN NATIONAL TEAM



Official Power Tool of the Mexican National Team™

The MNT™ is composed of the best soccer players around the world. They continue to be recognizably one of the top teams.

OFFICIAL POWER TOOL OF MAJOR LEAGUE SOCCER (MLS™)



OFFICIAL POWER TOOL

MLS™ is on the move with many of the top players joining the league and new teams developing season after season.



9920

3" x 24" BELT SANDER

Powerful 8.8 AMP Motor; Only 84dB

- Variable speed control dial (690-1,440 ft./min.) to match the speed to the application
- Electronic speed control maintains constant speed under load
- Auto-tracking belt system tracks belt without adjustment
- Innovative design for sanding flush to wall with nose and side of sander
- Front grip design for comfortable operation
- Dust bag for a cleaner work environment

Model 9920 Includes: 3" x 24" Abrasive Belt, 80 Grit (742312-8C-1), Dust Bag (122591-2)

Belt Size	3" x 24"
Belt Speed (variable speed)	690 - 1,440 ft./min.
AMPS	8.8
Overall Length	13-1/8"
Net Weight	9.9 lbs.
Shipping Weight	12.4 lbs.

9924DB

3" x 24" BELT SANDER

Low Profile Balanced Design

- Powerful 7.8 AMP motor for fast material removal
- Extended base to allow flush sanding
- Innovative design for sanding flush to wall with nose and side of sander
- Extra long cord for easier maneuverability
- Easy-release belt lever for quick belt changes
- Ball bearing construction for longer tool life

Model 9924DB Includes: 3" x 24" Abrasive Belt, 80 Grit (742312-8C-1), Dust Bag (122296-4)

Belt Size	3" x 24"
Belt Speed	1,300 ft./min.
AMPS	7.8
Overall Length	14"
Net Weight	10.6 lbs.
Shipping Weight	13.2 lbs.

9404

4" x 24" BELT SANDER

Variable Speed Control Dial

- Powerful 8.8 AMP motor for fast material removal
- Low noise (84dB) for operator comfort
- Auto-tracking belt system tracks belt without adjustment
- Innovative design for sanding flush to wall with nose and side of sander
- Long 16.4 ft. power cord for easier maneuverability
- Optional sanding shoe available for precise sanding depth control

Model 9404 Includes: 4" x 24" Abrasive Belt, 80 Grit (742322-9-1), Dust Bag (122591-2)

Belt Size	4" x 24"
Belt Speed (variable speed)	690 - 1,440 ft./min.
AMPS	8.8
Overall Length	13-1/8"
Net Weight	10.3 lbs.
Shipping Weight	12.7 lbs.



9403

4" x 24" BELT SANDER

Powerful 11 AMP Motor for High Production Use

- Low noise (84dB) for operator comfort
- 4" wide belt with a speed of 1,640 ft./min. for fast material removal
- Labyrinth construction seals and protects motor and bearings from contamination
- Large front grip is positioned for operator comfort
- Innovative design for sanding flush to wall with nose and side of sander

Model 9403 Includes: 4" x 24" Abrasive Belt, 80 Grit (742322-9-1), Dust Bag (122591-2)

Belt Size	4" x 24"
Belt Speed	1,640 ft./min.
AMPS	11
Overall Length	13-7/8"
Net Weight	12.6 lbs.
Shipping Weight	15.6 lbs.



9741

WHEEL SANDER

Unique Design for More Controlled Operation

- Powerful 7.8 AMP motor delivers 3,500 RPM for fast and efficient paint and rust removal; brings out wood grain
- Innovative design for sanding flush to wall with nose and side of sander
- Adjustable front roller for uniform pressure to workpiece
- Well balanced with a low center of gravity for easier operation
- Electric brake for maximum productivity

Model 9741 Includes: Nylon Brush Wheel, 100 Grit, Medium (794379-6), (2) Wrench (783204-6)

Wheel Size (width x diameter)	4-3/4" x 4"
No Load Speed	3,500 RPM
AMPS	7.8
Overall Length	12-1/4"
Net Weight	9.3 lbs.
Shipping Weight	18 lbs.



1002BA

4-3/8" CURVED BASE PLANER

Large Planing Width Engineered for an Even Cut

- Powerful 9.6 AMP motor with 15,000 RPM for improved performance
- Precision machined base for notching out logs at a 12-5/8" curved radius
- Large ejection chute for high rate of chip discharge
- Conveniently located front and rear grips for operator control
- Lock-on button for continuous operation

Model 1002BA Includes: 4-3/8" Planer Blade, High Speed Steel, 2/pk (793008-8), Sharpening Holder (123055-9), Blade Gauge (123010-1), Socket Wrench (782209-3)

Planing Width	4-3/8"
Planing Depth	3/16"
No Load Speed	15,000 RPM
AMPS	9.6
Overall Length	13-11/32"
Net Weight	11.4 lbs.
Shipping Weight	15.4 lbs.



KP0800K

3-1/4" PLANER, WITH TOOL CASE
High Power-to-Weight Ratio;
Weighs Only 5.7 lbs.

- 6.5 AMP motor delivers more output power for increased stock removal and superior finishes
- Planes up to 3-1/4" wide and 3/32" deep in a single pass
- Two-blade cutter head with 17,000 RPM delivers smooth finish and fast stock removal
- Spring-loaded stand elevates the base to protect the workpiece
- Easy blade setting system for fast blade installation

Model KP0800K Includes: 3-1/4" Planer Blade Set (D-46246), Blade Gauge (123062-2), Socket Wrench (782209-3), Guide Rule (165581-2), Tool Case

Planing Width	3-1/4"
Planing Depth	3/32"
No Load Speed	17,000 RPM
AMPS	6.5
Overall Length	11-1/4"
Net Weight	5.7 lbs.
Shipping Weight	12 lbs.



KP0810

3-1/4" PLANER KIT
Powerful with Less Weight
(7.5 AMP Motor; 7.3 lbs.)

- Planes up to 3-1/4" wide and 5/32" deep in a single pass
- Two-blade cutter head with 16,000 RPM delivers smooth finish and fast stock removal
- Chip ejection can be directed to either side of the tool for convenience
- Depth knob features an easy-to-read scale with stops in 0.1 mm increments for precise depth adjustment
- Rubberized grip and depth adjustment knob for comfort

Model KP0810 Includes: 3-1/4" Planer Blade Set (D-46246), Blade Gauge (123062-2), Socket Wrench (782209-3), Guide Rule (122785-9)

Planing Width	3-1/4"
Planing Depth	5/32"
No Load Speed	16,000 RPM
AMPS	7.5
Overall Length	11-3/8"
Net Weight	7.3 lbs.
Shipping Weight	10.2 lbs.



XPK01

3.0Ah BATTERY

18v LXT® 3-1/4" PLANER KIT
Planes Up to 3-1/4" Wide and 5/64" Deep in a Single Pass

- 2-blade cutter head with double edge carbide blades for added performance and smooth finish
- High power-to-weight ratio; weighs only 7.4 lbs.
- 14,000 RPM motor engineered for fast stock removal
- Click depth adjustment knob with easy-to-read scale with settings from 0" to 5/64"
- Spring-loaded stand elevates the base to protect the blades and workpiece

Model XPK01 Includes: (2) 18V LXT® Lithium-Ion 3.0Ah Battery (BL1830), 18V Lithium-Ion Rapid Optimum Charger (DC18RC), 3-1/4" Planer Blade Set (D-46246), Blade Gauge (123062-2), Socket Wrench (782209-3), Tool Bag

Model XPK012 Includes: Tool Only; Battery and Charger not included

Planing Width	3-1/4"
Planing Depth	5/64"
No Load Speed	14,000 RPM
Battery	18V LXT® Lithium-Ion
Overall Length	13-1/8"
Net Weight (with battery)	7.4 lbs.
Shipping Weight	16.3 lbs.



1912B

4-3/8" PLANER
Planes up to 4-3/8" Wide and 1/16" Deep

- Powerful 7.5 AMP motor for improved performance
- Two-blade cutter head with 16,000 RPM delivers smooth finish and fast stock removal
- Lock-on button for continuous operation
- V-groove on front shoe for easy chamfer cutting
- Precision machined aluminum base for planing accuracy

Model 1912B Includes: 4-3/8" Planer Blade, High Speed Steel, 2/pk (793008-8), Sharpening Holder (123055-9), Blade Gauge (123062-2), Socket Wrench (782209-3), Guide Rule (164371-0)

Planing Width	4-3/8"
Planing Depth	1/16"
No Load Speed	16,000 RPM
AMPS	7.5
Overall Length	14"
Net Weight	9.3 lbs.
Shipping Weight	10.9 lbs.



1806B

6-3/4" PLANER
Unrivalled for Shear Power and Performance

- Powerful 10.9 AMP motor with 15,000 RPM for improved performance
- Cuts 6-3/4" width in a single pass
- Comfortable handle and easy depth setting
- Large, sturdy sole plate for added stability
- Perfect alignment of front and back grips for better control

Model 1806B Includes: 6-3/4" Planer Blade, High Speed Steel, 2/pk (793186-4), Hex Wrench (783202-0), Triangular Rule (762001-3), Bevel Guide (123053-3), Sharpening Holder Assembly (123006-2), Tool Case

Planing Width	6-3/4"
Planing Depth	1/16"
No Load Speed	15,000 RPM
AMPS	10.9
Overall Length	20-3/4"
Net Weight	19.8 lbs.
Shipping Weight	33 lbs.



KP312

12-1/4" PLANER
Precision Engineered for an Even Cut Every Time

- Powerful 15 AMP motor with 12,000 RPM for improved performance
- Large, conveniently located depth setting knob for easy adjustment
- Poly "V" belt designed with grooves efficiently transfers power from the motor to the blades
- Large ejection chute for high rate of chip discharge
- Front roller for easy moving over rough materials

Model KP312 Includes: 12" Planer Blade, HSS, 2/pk (B-02870), Socket Wrench (782209-3), Triangular Rule (762001-3)

Planing Width	12-1/4"
Planing Depth	1/8"
No Load Speed	12,000 RPM
AMPS	15
Overall Length	21-3/4"
Net Weight	40.6 lbs.
Shipping Weight	50.6 lbs.



PJ7000

PLATE JOINER
Rack-and-Pinion Vertical Fence Adjustments

- Powerful 5.6 AMP motor delivers 11,000 RPM for quick, precise cutting in a variety of woods
- Cast aluminum pivot fence with three positive stops at 0°, 45° and 90°
- Six depth settings with one-touch stops for most common biscuits sizes including #0, #10, and #20
- Large and easy-to-operate cam locks for fence adjustments
- Large top grip handle for improved handling
- Slim and ergonomic body design for added comfort

Model PJ7000 Includes: 4" Carbide Tipped Blade for Plate Joiner (A-95118), Angle Guide (123148-2), Dust Bag (123150-5), Set Plate (415579-2), Lock Nut Wrench (782401-1), Tool Case

Blade Diameter	4"
Max. Cutting Depth	3/4"
No Load Speed	11,000 RPM
AMPS	5.6
Overall Length	11-7/8"
Net Weight	5.5 lbs.
Shipping Weight	8 lbs.



XJP03Z

Tool only - battery and charger not included

18v LXT® PLATE JOINER
Delivers up to 300 Cuts for #0 Biscuits on a Single Charge

- Rack-and-pinion vertical fence system engineered for accurate fence adjustments
- Cast aluminum pivot fence with three positive stops at 0°, 45° and 90°, and easy centering on 3/4" material
- Six depth settings with one-touch stops for #0, #10, and #20 and most common biscuits sizes
- Cordless plate joiner provides portability and performance in the field or in the shop without the cord
- Large and easy-to-operate cam locks for fence adjustments

Model XJP03Z Includes: Tool Only; Battery and Charger not included

Blade Diameter	4"
Cutting Capacity (depth)	3/4"
No Load Speed	6,500 RPM
Battery	18V LXT® Lithium-Ion
Overall Length	13-3/4"
Net Weight (with battery)	6.7 lbs.
Shipping Weight	8.2 lbs.



98202

BLADE SHARPENER Precision Sharpening of Planer Blades and More

- Ideal for sharpening woodworking planer blades, bevel and lathe chisels, and jointer knives
- Quiet motor delivers 560 RPM for a fine finish
- Large 7-7/8" aluminum-oxide wheel for efficient sharpening
- Sharpens blades up to 15-3/4" long
- Water feed for cooling blades

Model 98202 Includes: Grinding Wheel, 1,000 Grit (Medium), 98202 (A-24614), Wrench (341391-3), Rule Assembly (122209-5)

Wheel Size	7-7/8"
No Load Speed	560 RPM
AMPS	1.1
Overall Length	15-3/8"
Net Weight	24.3 lbs.
Shipping Weight	26.9 lbs.

7104L

CHAIN MORTISER Ideal for Timber Framing or Log Home Building

- Razor sharp chain for clean, accurate cutting
- Extremely portable at only 38.1 lbs.
- 10.5 AMP motor (3,200 RPM) to quickly notch or cut holes in thick wood stock
- Cuts lap joints up to 5-1/8"
- Large adjustable vise and knob for versatility

Model 7104L Includes: 21/32" Mortiser Chain (A-16570), Wrench (781204-0), Bar Chain Oil, 100 cc (182229-1)

Max. Hole Width (longitudinal)	5-1/8"
Max. Hole Width (transverse)	1-1/4"
Max. Hole Depth	6-1/8"
No Load Speed	3,200 RPM
Chain Speed	1,000 FPM
AMPS	10.5
Overall Length	20-1/8"
Net Weight	38.1 lbs.
Shipping Weight	44 lbs.

UB1103

BLOWER Delivers a Maximum Air Speed of 203 MPH for Faster Job Site Clean Up

- Variable speed control dial and trigger (0-16,000 RPM) for increased performance
- Maximum air volume of 145 cfm for faster clean up in larger areas
- Two tools in one; quickly converts to a vacuum for added versatility
- Large trigger with conveniently located lock-on button

Model UB1103 Includes: Rubber Blower Nozzle (132025-7), Dust Bag (122814-8)

AMPS	6.8
Max Air Volume	145 CFM
Max. Air Velocity	203 MPH
No Load Speed (variable speed)	0 - 16,000 RPM
Overall Length	18-7/8"
Net Weight	4.3 lbs.
Shipping Weight	6.6 lbs.

HG551V

HEAT GUN Low Vibration and Noise, Ideal for Indoor Applications

- Variable temperature control dial (180 - 1,020°F) with number settings for precise control over a wide variety of applications
- Ideal for stripping paint and varnish, thawing frozen metal pipes, loosening tile and putty, re-melting adhesive, vehicle wraps, and more
- Compact 1.3 lb. design features a rubberized pistol grip handle and an integrated rear stand
- 2-speed blower settings (8.8 and 16 CFM) for greater versatility
- Thermocouple control maintains precise temperature

Model HG551V Includes: Tool Case

Air Temperature (var. speed)	180° - 1,020° F
Air Volume (2 speed)	8.8 and 16 CFM
AMPS	12
Watts (AC only)	1,400
Overall Length	9"
Net Weight	1.3 lbs.
Shipping Weight	3.6 lbs.

Woodworking Accessories

Planer Accessories

Tungsten-Carbide Planer Blade

- Specially designed for fast and smooth planing
- Long lasting tungsten-carbide

Size	Model	2 Per. Pkg. Part #
3-1/4"	N1900B, KP0810, KP0800K, XPK01	D-17223
4-3/8"	1912B	D-17245

High-Speed Steel Planer Blade

- Made of fine grade steel
- Specially designed for fast and smooth planing

Size	Model	2 Per. Pkg. Part #
3-1/4"	N1900B, KP0810, KP0800K, XPK01	D-46230
4-3/8"	1912B, 1002BA	793008-8
6-3/4"	1806B	793186-4
12"	KP312	B-02870

Double Edged Tungsten-Carbide Planer Blade

Type	Size	Model	2 Per. Pkg. Part #
Blade only ¹	3-1/4"	N1900B, KP0810, KP0800K, XPK01	D-46246
With set plates	3-1/4"	N1900B, KP0810, KP0800K, XPK01	D-17239

¹ For use with set plate 343433-9

Blade Gauge Assembly

For fast accurate blade setting



Model	Part #
N1900B, KP0800K	123010-1
1902, KP0810	123062-2

Bevel Guide

0 - 45° bevel cuts



Model	Part #
N1900B, KP0800K, KP0810	123060-6

Dust Nozzle

For non-clogging chip deflection in desired direction



Model	Part #
N1900B	132351-4 ² 181572-5

Adapters for connecting Vacuum



Model	Part #
KP312	193733-5
KP0800K	451329-1

Sharpening Holder

For honing dull blades with sharpening stone

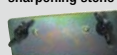

Model	Part #
N1900B, KP0810, KP0800K	123004-6

Straight Guide Rule

To ensure straight cuts



Model	Part #
N1900B, 1912B, 1902	164371-0
KP0810	122785-9
KP0800K	165581-2

Sharpening Stone



Model	Part #
All Planers	794061-7

Depth Guide



Model	Part #
KP0800K, N1900B	191725-8

Dust Bag



Model	Part #
KP0800K, KP0810	122793-0
N1900B	122230-4

Chain Mortiser Accessories

Description	Model	Part #
Cutter Chain 19/32"		A-16564
Cutter Chain 21/32"		A-16570
Cutter Chain 23/32"	7104L	A-16586
Cutter Chain 53/64"		A-16592
Cutter Chain 15/16"		A-16601

Heat Gun Accessories

3" Surface Nozzle

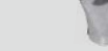

Model	Part #
HG551V	P-71423
HG1100	110702-A

3/8" Reflector Nozzle

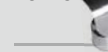

Model	Part #
HG551V	P-71445
HG1100	110746-A

3/8" Reduction Nozzle

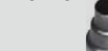

Model	Part #
HG551V	P-71439
HG1100	110706-A

Blade Sharpener Accessories

Description	Model	Part #
7" Grinding Wheel 60 Coarse		A-24620
1000 Medium	98202	A-24614
6000		A-24636
Maximum Safe Speed: Fine 1,200 RPM		
Guide Assembly Tool rest for knife and scissors	98202	192612-4

PNEUMATICS

**2-1/2"
Siding Coil Nailer**
AN611



PNEUMATICS

COMPRESSORS

pgs. 84-85

HIGH PRESSURE

pg. 85

NAILERS / STAPLERS

pgs. 85-86

ACCESSORIES

pg. 86

PERFORMANCE

"V" Twin Style Pump runs cooler and provides 12.5 CFM at 100 PSI for faster recovery time

POWER

Powerful Honda® GX160 4-stroke engine for increased performance and superior reliability

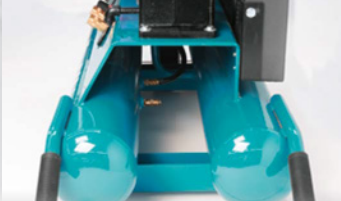
CAPACITY

10-gallon twin tanks provide air supply to multiple nailers

PERFORMANCE YOU NEED

BIG BORE™
MAC5501G

5.5 HP* BIG BORE™ GAS AIR COMPRESSOR
 "V" Twin Style Pump runs cooler and provides 12.5 CFM at 100 PSI

- Powerful Honda GX160 4-stroke engine for increased performance and superior reliability
- 10-gallon twin tanks provide air supply to multiple nailers
- Cast iron pump with Big Bore™ cylinder and piston is engineered to provide faster recovery time for improved performance
- Industrial-grade recoil starter with ergonomic grip and recoil rope design for faster, easier starts

Model MAC5501G Includes: (2) 1/4" Universal Quick Coupler, Male (447013-E)

Maximum Horsepower	5-1/2 HP
Running Horsepower	5.5 HP
Tank	10 gal.
Performance:	40 PSI (14 CFM), 90 PSI (12.5 CFM)
Maximum Pressure	135 PSI
Overall Length	46"
Net Weight	190 lbs.
Shipping Weight	233 lbs.
Pump	Oil lubricated

MAC5200

3.0 HP* BIG BORE™ AIR COMPRESSOR
 Powerful Enough to Run Two Framing Nailers

- Cast iron pump with Big Bore™ cylinder and piston is engineered to provide faster recovery time for improved performance
- Powerful 3.0 HP* motor produces 6.5 CFM at 90 PSI for increased productivity
- Pump is oil lubricated for cooler running temperatures and reduced wear
- Durable cast iron cylinder reduces wear and increases pump life
- Folding handle with low-profile design for easy storage

Model MAC5200 Includes: Air Compressor Oil (181122-A), 1/4" Universal Quick Coupler, Male (447013-E)

Maximum Horsepower	3 HP
Running Horsepower	2.1 HP
Tank	5.2 gal.
Performance:	40 PSI (6.9 CFM), 90 PSI (6.5 CFM)
Maximum Pressure	140 PSI
Net Weight	88 lbs.
Shipping Weight	107 lbs.
Pump	Oil lubricated

BIG BORE™
MAC2400

2.5 HP* BIG BORE™ AIR COMPRESSOR
 Pump Runs at Lower RPM Resulting in Lower Noise (79dB)

- Cast iron pump with Big Bore™ cylinder and piston is engineered to provide faster recovery time for improved performance
- Powerful 2.5 HP 4-Pole motor produces 4.2 CFM at 90 PSI for increased productivity and lower noise
- Roll-cage construction provides complete protection to withstand extreme jobsite environments
- Low AMP draw reduces incidences of tripped breakers at start up
- Copper finned discharge tubing for increased heat dissipation and reduced water in the tank

Model MAC2400 Includes: Air Compressor Oil (181122-A), 1/4" Universal Quick Coupler, Male (447013-E)

Maximum Horsepower	2-1/2 HP
Running Horsepower	2.1 HP
Tank (twin stacked)	4.2 gal.
Performance:	40 PSI (4.8 CFM), 90 PSI (4.2 CFM)
Maximum Pressure	130 PSI
Net Weight	77 lbs.
Shipping Weight	86.3 lbs.
Pump	Oil lubricated

BIG BORE™
MAC700

2.0 HP* BIG BORE™ AIR COMPRESSOR
 Low Noise, Low AMP Draw and High Output

- Cast iron pump with Big Bore™ cylinder and piston is engineered to provide faster recovery time for improved performance
- Powerful 2.0 HP 4-Pole motor produces 3.3 CFM at 90 PSI for increased productivity and lower noise
- Pump runs at lower RPM (1,730) resulting in lower noise (80dB) and improved pump durability
- Low AMP draw reduces incidences of tripped breakers at start up
- Roll-bar handle for portability and additional protection

Model MAC700 Includes: Air Compressor Oil (181122-A), 1/4" Universal Quick Coupler, Male (447013-E)

Maximum Horsepower	2 HP
Running Horsepower	1.7 HP
Tank	2.6 gal.
Performance:	40 PSI (3.8 CFM), 90 PSI (3.3 CFM)
Maximum Pressure	130 PSI
Net Weight	52 lbs.
Shipping Weight	60.5 lbs.
Pump	Oil lubricated

AC001

COMPACT AIR COMPRESSOR
 Low Noise and Less Weight

- Powerful 1/6 maximum horsepower* induction motor provides up to 125 PSI
- Lightweight design (23.1 lbs.) for increased job site portability
- Low noise for operator comfort; ideal for indoor use
- Low AMP draw reduces incidents of tripped breakers at start-up
- Roll cage construction for extra protection of pump and motor assembly

Model AC001 Includes: 1/4" Universal Quick Coupler, Male (447013-E)

Motor	1/6 HP
Running Horsepower	1/6 HP
Tank	1 gal.
Performance:	40 PSI (.58 CFM), 90 PSI (.45 CFM)
Maximum Pressure	125 PSI
Net Weight	23.1 lbs.
Shipping Weight	26.9 lbs.
Pump	Oil-less

*Maximum horsepower



ADVANTAGES OF MAKITA[®] HIGH PRESSURE

MORE POWER

High pressure compressor technology delivers 400 PSI

LESS WEIGHT

Nailers are up to 30% less weight than conventional nailers

BETTER PERFORMANCE

Dual-head (2-stage) pump compressor provides faster recovery time

INCREASED EFFICIENCY

Low amp draw reduces tripped breakers and voltage drop during start-ups

MORE POWER MORE CONSISTENCY

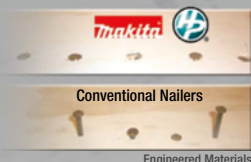

Drive larger nails (3-1/2" x .162" size) more consistently in engineered materials



PNEUMATICS

AC310H

2.5 HP* HIGH PRESSURE AIR COMPRESSOR High Pressure Technology Delivers 400 PSI Capacity

- Dual capacity: two universal couplers for conventional nailers and two couplers for high pressure nailers
- Low amp draw reduces incidences of tripped breakers and voltage drop during start-ups
- Efficient dual-head (2-stage) pump provides faster recovery time and improved performance
- Pump runs at lower RPM (1,720) resulting in lower noise and improved pump durability

Model AC310H Includes: (2) 1/4" High Pressure Universal Quick Coupler, Female (HY00000337), (2) High Pressure Quick Coupler (HY00000351)

Maximum Horsepower	2-1/2 HP
Running Horsepower	1.9 HP
Tank	1.6 gal.
Performance:	
40 PSI (3.7 CFM), 90 PSI (3.6 CFM), 300 PSI (2.7 CFM)	
Maximum Pressure	400 PSI
Net Weight	79.4 lbs.
Shipping Weight	88.16 lbs.



PNEUMATICS

AN930H

3-1/2" HIGH PRESSURE FRAMING COIL NAILER Superior Power-to-Weight Ratio

- Up to 30% less weight (5.7 lbs.) and up to 30% smaller than conventional framing nailers
- "Tool-less" depth adjustment engineered for more precise flush and countersink nailing
- 2-mode trigger allows operator to select sequential or contact nailing options
- High capacity canister holds up to 300 nails for high production applications
- High Pressure technology enables nailer to operate at 170-320 PSI for more consistent flush nailing

Model AN930H Includes: (424390-1), Air Tool Oil (194381-3), Tool Case, Safety Goggles

Operating Air Pressure	170 - 320 PSI
Nail Size	1-3/4" - 3-1/2" .099" - .148" shank diameter wire collated
Nail Size (in., ga.)	1-3/4" to 3-1/2" (ga.)
Magazine Capacity (range)	150 - 300
Dimensions (LxWxH)	11-1/4" x 5" x 13"
Overall Length	11-1/4"
Net Weight	5.7 lbs.
Shipping Weight	12.4 lbs.



PNEUMATICS

AN610H

2-1/2" HIGH PRESSURE SIDING COIL NAILER Delivers Precise Flush Nailing

- Innovative high pressure technology enables nailer to operate at 320 PSI for more consistent flush nailing
- "Tool-less" depth adjustment engineered for more precise flush and countersink nailing
- 2-mode selector switch allows operator to select sequential or contact nailing options
- Multi-directional exhaust port directs exhaust air away from operator
- High capacity canister holds up to 400 nails for high production applications

Model AN610H Includes: No-Mar Tip (421574-2), Air Tool Oil (194381-3), Tool Case, Safety Goggles (192517-8)

Operating Air Pressure	140 - 320 PSI
Nail Size	1-1/4" - 2-1/2" .080" - .113" shank diameter
Magazine Capacity (range)	200 - 400
Dimensions (LxWxH)	11-1/8" x 5-3/8" x 10-7/8"
Net Weight	4.2 lbs.
Shipping Weight	7.94 lbs.



PNEUMATICS

AN923

21"

3-1/2" FRAMING NAILER Drives up to 3-1/2" x .162" (16d) Nails

- 3-Mode selector switch (contact, sequential, lock) allows user control over nailing options
- Large capacity air chamber for increased power to drive nails varying in length from 2" to 3-1/2"
- Built-in air filter minimizes dust and debris from entering tool
- Anti-dry mechanism stops tool when three nails remain in the magazine
- Solid rear-loading aluminum magazine for longer life

Model AN923 Includes: Pneumatic Nailer Oil (181434-7), Tool Hook (122742-7), Safety Goggles (191687-A), Air Fitting (311006-A)

Operating Air Pressure	65 - 120 PSI
Nail Size	2" - 3-1/2" .113" - .162" shank diameter plastic or wire collated
Magazine Capacity (range)	64 - 74
Dimensions (LxWxH)	22" x 4-1/4" x 13-11/16"
Net Weight	8.7 lbs.
Shipping Weight	12.3 lbs.



PNEUMATICS

AN902

15"

3-1/2" FRAMING COIL NAILER More Power and Less Weight for Increased Versatility

- "Tool-less" depth adjustment engineered for more precise flush and countersink nailing
- Drives 1-3/4" to 3-1/2" coil framing nails
- Easy access nose design for clearing jammed nails
- Easy loading canister with nail size adjustment provides maximum versatility
- Rubberized handle for better fit and added comfort
- Contact mode trigger allows operator to control nailing operations

Model AN902 Includes: Pneumatic Nailer Oil (181434-7), Safety Goggles (191687-A), No-Mar Tip (BA00000372)

Operating Air Pressure	60 - 120 PSI
Nail Size	1-3/4" - 3-1/2" .099" - .148" shank diameter wire collated
Magazine Capacity (range)	150 - 300
Dimensions (LxWxH)	12-1/2" x 5" x 14-7/8"
Net Weight	7.7 lbs.
Shipping Weight	10.1 lbs.



PNEUMATICS

AN611

15"

2-1/2" SIDING COIL NAILER "Tool-less" Depth Adjustment with 9 Settings

- "Tool-less" depth adjustment engineered for more precise flush and countersink nailing
- 3-mode selector switch (contact, sequential, lock) allows user control over nailing options
- Built-in air filter minimizes dust and debris from entering tool
- Multi-directional exhaust port directs exhaust air away from user
- Easy-loading canister with nail size adjustment provides maximum versatility

Model AN611 Includes: Pneumatic Nailer Oil (181434-7), Hex Wrench (783202-0), Safety Goggles (191687-A), Air Fitting (311006-A), Tool Case

Operating Air Pressure	65 - 120 PSI
Nail Size	1-1/4" - 2-1/2" .080" - .099" shank diameter
Magazine Capacity (range)	200 - 400
Dimensions (LxWxH)	13-1/16" x 5" x 12-1/2"
Net Weight	5.1 lbs.
Shipping Weight	10.15 lbs.

High Pressure Accessories

High Pressure Contractor Hose

- Up to 2X less weight than heavier hoses, ideal for trim roofing, framing and construction
- Highly flexible and less kinks for easy rolling and improved air flow
- Engineered to be more durable than vinyl hoses for longer life and improved performance
- All-weather resistant, engineered to maintain flexibility even under extreme weather conditions

Size	Model	Part #
100'	AC310H, AN610H, AN930H	B-80020
50'		B-80014

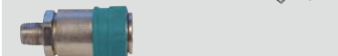

High Pressure Quick Coupler

Size	Style	Model	Part #
1/4"	Male	AC310H	HY00000351

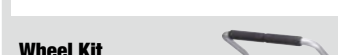

Wheel Kit for AC310H

- Solid rubberized wheels for easy job site portability
- Large rubberized handle for added control and comfort

Model	Part #
AC310H	HY00000212

AC310H Sold Separately

*Maximum horsepower

AN453
15"
1-3/4" ROOFING COIL NAILER
 Easy-Loading Adjustable Canister

- Aluminum housing for longer tool life
- "Tool-less" depth adjustment engineered for more precise control and flush nailing
- "Tool-less" shingle guide designed for easy adjustments and consistent shingle placement
- Built-in magnet ensures last nail is driven
- Large carbide inserts on nosepiece for long lasting performance

Model AN453 Includes: Hex Wrench (783202-0), Pneumatic Nailer Oil (181434-7), Safety Goggles (192517-8), Air Fitting (311006-A)

Operating Air Pressure	65 - 120 PSI
Nail Size	3/4" - 1-3/4"
Dimensions (LxWxH)	10-3/8" x 4-5/8" x 10-5/8"
Net Weight	5.2 lbs.
Shipping Weight	7.83 lbs.

FINISHED TO PERFECTION

PERFORMANCE

"Tool-less" quick-release cam-lock open nail guide assembly to easily clear jammed nails

AF505N
18"
2" BRAD NAILER
 Narrow nose design allows easy nailing access in confined areas

- "Tool-less" quick-release cam-lock opens nail guide assembly to easily clear jammed nails; efficient design minimizes downtime
- Easy to use "tool-less" depth adjustment dial for a wide variety of finish applications
- Multi-directional exhaust port rotates 360° to direct exhaust air away from user
- Tool hook can be rotated 180° so tool can remain close by, but never in the way
- 1.5 SCFM @ 90PSI

Model AF505N Includes: Pneumatic Nailer Oil (181434-7), (2) No-mar tip (HY00000378), Air Fitting (311006-A), Tool Case, Safety Goggle

Operating Air Pressure	60 - 115 PSI
Nail Size	5/8" to 2" (18 ga.)
Magazine Capacity	100
Dimensions (LxWxH)	10-1/4" x 2-1/2" x 9-3/8"
Net Weight	3 lbs.
Shipping Weight	7.7 lbs.

AT638
18"
1/4" NARROW CROWN STAPLER
 Engineered for More Precise Finish

- Depth adjustment engineered for more precise flush and countersink finish
- Multi-directional exhaust port directs exhaust air away from user
- Staple reload indicator window alerts the user when to reload staples
- Contact arm and trigger are used together for controlled driving
- Top-loading magazine allows user to quickly load staples

Model AT638 Includes: Hex Wrench (783202-0), Hex Wrench (783201-2), Pneumatic Nailer Oil (181434-7), Safety Goggles (192517-8), Tool Case

Operating Air Pressure	60 - 115 PSI
Gauge	18
Leg Length	5/8" to 1-1/2"
Crown	1/4"
Magazine Capacity	100
Dimensions (LxWxH)	9-3/4" x 2-7/16" x 9-3/4"
Net Weight	3.2 lbs.
Shipping Weight	6.1 lbs.

AT1150A
16"
7/16" MEDIUM CROWN STAPLER
 Clear Jammed Nails Easily with Cam-Lock

- Depth adjustment engineered for more precise flush and countersink stapling
- Quick release cam-lock opens nose assembly to clear jammed staples
- Built-in air filter minimizes dust and debris from entering the tool
- Ideal for crating, decking, insulation, and sheathing applications
- Top loading magazine allows user to quickly load 16 GA 7/16" staples varying in length from 1" to 2"
- Multi directional exhaust port directs exhaust air away from user

Model AT1150A Includes: Hex Wrench (A0913-0011), Hook (A0316-0311), Oil Supply (A09070001), Safety Goggles (A09080-171), Air Fitting (311006-A)

Operating Air Pressure	65 - 120 PSI
Gauge	16
Leg Length	1" to 2"
Crown	7/16"
Magazine Capacity	140
Dimensions (LxWxH)	14-1/2" x 3-7/16" x 11-3/8"
Net Weight	4.9 lbs.
Shipping Weight	6.75 lbs.

AT2550A
16"
1" WIDE CROWN STAPLER
 Lightweight Design for Comfort and Control

- Depth adjustment engineered for more precise flush and countersink finish
- Quick release cam-lock opens nose assembly to clear jammed staples
- Built-in air filter minimizes dust and debris from entering the tool
- Ideal for lathing, roofing and sheathing
- Top-loading magazine allows operator to quickly load 16 gauge, 1" wide crown staples from 1" to 2" in length
- Multi directional exhaust port directs exhaust air away from user

Model AT2550A Includes: Hex Wrench (A0913-0011), Hook (A0316-0311), Oil Supply (A09070001), Safety Goggles (A09080-171), Air Fitting (311006-A)

Operating Air Pressure	65 - 120 PSI
Gauge	16
Leg Length	1" to 2"
Crown	1"
Magazine Capacity	140
Dimensions (LxWxH)	14-1/2" x 3" x 10-1/4"
Net Weight	5.1 lbs.
Shipping Weight	7.1 lbs.

Pneumatic Accessories
Polyurethane Contractor Air Hose

Size	Model	Part #
1/4" x 50'	MAC700, MAC2400,	T-01133
1/4" x 100'	MAC5200	T-01149

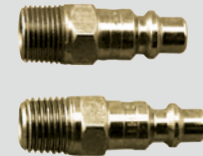
Air Fittings

(for Models MAC700, MAC2400, MAC5200)

Type	Thread Size	Thread Style	Part #
1/4" Industrial (1/4" Body)	1/4"	Male	311006-A
	1/4"	Female	311002-A
	3/8"	Female	311003-A
3/8" Industrial (3/8" Body)	1/4"	Female	311010-A
	1/4"	Female	311004-A
1/4" Automotive (1/4" Body)	3/8"	Female	311005-A
	1/4"	Male	311008-A
	3/8"	Male	311009-A
3/8" Automotive (3/8" Body)	1/4"	Female	311012-A
	3/8"	Female	311013-A
	1/4"	Male	311016-A
	3/8"	Male	311017-A

Tool First Aid Repair Kit

- For air leakage repairs
- Fixes sluggish operation problems
- Comes with repairing instruction manual
- Includes complete top, bottom & driver maintenance equipment

Model	Part #
AN611	193007-4
AN451	192393-0
AN923	194522-1
AF502	192539-8
AN453	HY00000384

Universal Quick Coupler

Style	Thread Size	Thread Style	Model	Part #
Fits 1/4" automotive & industrial fittings	1/4"	Male	MAC700, MAC2400, MAC5200	447013-E
	1/4"	Female	MAC5200	311018-A
	1/4"	Female	AC310H	HY00000337

MM4[®]

4-STROKE ENGINE

75.6 cc MM4[®] Hip Throttle Backpack Blower
EB7650WH



POWER EQUIPMENT

MM4[®]
BLOWERS



pg. 88

MM4[®]
TRIMMERS



pg. 89

CHAIN SAWS



pgs. 90-91

ELECTRIC



pg. 91

LXT[®]
CORDLESS



pgs. 92-93

ACCESSORIES



pg. 94

NO FUEL MIX NEEDED



MM4
4-STROKE ENGINE

EB7650TH

75.6 cc MM4® BACKPACK BLOWER
High Air Volume (670 CFM) and Air Speed (200 MPH) for Commercial Duty Performance

- Powerful fuel efficient 75.6 cc (3.8 HP) MM4® commercial duty engine
- Mechanical automatic engine decompression for quick and easy starts
- Shoulder straps engineered with multiple adjustments for improved fit
- Tool-less handle adjustment for quick positioning of handle

Model EB7650TH Includes: End Nozzle 90-70 (455128-3), End Nozzle 90-60 (454896-5), Flat Nozzle 90 (454916-5), Oil Bottle (242072-1)

Engine Displacement (cc)	75.6 cc
Engine (HP)	3.8 HP
Max Air Volume	670 CFM
Max. Air Velocity	200 MPH
Fuel Type	Unleaded gas
Fuel Tank Capacity	64 oz.
Crank Case Capacity	7.4 oz.
Sound Pressure	76 dB(A)
Dry Weight	24.1 lbs.
Shipping Weight	33.9 lbs.



MM4
4-STROKE ENGINE

EB7650WH

75.6 cc MM4® HIP THROTTLE BACKPACK BLOWER
High Air Volume (670 CFM) and Air Speed (200 MPH) for Commercial Duty Performance

- Powerful fuel efficient 75.6 cc (3.8 HP) MM4® commercial duty engine
- Mechanical automatic engine decompression for quick and easy starts
- Hip throttle with cruise control and convenient on/off switch
- Shoulder straps engineered with multiple adjustments for improved fit

Model EB7650WH Includes: End Nozzle 90-60 (454896-5), Flat Nozzle 90 (454916-5), End Nozzle 90-70 (455128-3), Oil Bottle (242072-1)

Engine Displacement (cc)	75.6 cc
Engine (HP)	3.8 HP
Max Air Volume	670 CFM
Max. Air Velocity	200 MPH
Fuel Type	Unleaded gas
Fuel Tank Capacity	64 oz.
Crank Case Capacity	7.4 oz.
Sound Pressure	76 dB(A)
Dry Weight	24.1 lbs.
Shipping Weight	40 lbs.



MM4
4-STROKE ENGINE

BBX7600N

75.6 cc MM4® BACKPACK BLOWER
Efficient 4-Stroke Engine, No Fuel Mix Required

- Powerful and fuel efficient 75.6 cc. 4-stroke commercial duty engine
- Mechanical automatic engine decompression for quicker, easier starts
- Padded shoulder straps and back panel for improved operator comfort
- Compact design with less weight (22.6 lbs.) for easier operation in confined areas

Model BBX7600N Includes: End Pipe (667-95019-00), Tool Kit, BBX2500 (690-90590-00), Straight Pipe (667-95018-01)

Engine Displacement (cc)	75.6 cc
Engine (HP)	3.8 HP
Max. Air Velocity	195 MPH
Air Volume	526 CFM
Fuel Type	Unleaded gas
Fuel Tank Capacity	64.2 oz.
Crank Case Capacity	7.4 oz.
Sound Pressure	74 dB(A)
Dry Weight	22.6 lbs.
Shipping Weight	29.1 lbs.



MM4
4-STROKE ENGINE

BHX2500CA

24.5 cc MM4® BLOWER
No Fuel Mix Required, Lower Emissions

- Soft grip for less vibration, and convenient cruise control lever
- Compact design with less weight (only 9.8 lbs.)
- Mechanical Automatic Engine Decompression for quicker, easier starts
- Large capacity muffler ensures quieter operation at 67dB(A)
- Dual stage air filter is replaceable and easily accessible

Model BHX2500CA Includes: Extension Pipe (665-95009-00), Round End Nozzle (665-95010-00), Tool Kit (690-90590-00)

Engine Displacement (cc)	24.5 cc
Engine (HP)	1.1 HP
Max Air Volume	356 CFM
Max. Air Velocity	145 MPH
Fuel Type	Unleaded gas
Fuel Tank Capacity	17.6 oz.
Crank Case Capacity	2.7 oz.
Sound Pressure	67 dB(A)
Dry Weight	9.8 lbs.
Shipping Weight	10 lbs.



MM4
4-STROKE ENGINE

PM7650H

75.6 cc MM4® MIST BLOWER
Efficient 4-Stroke Engine, No Fuel Mix Required

- Powerful fuel efficient 75.6 cc (3.67 HP), MM4® 4-stroke, commercial duty engine
- L-shaped chemical tank lowers center of gravity for improved balance
- Single action switch to activate liquid chemical flow
- Liquid chemical in tank is automatically mixed by intake air flow for uniform solution concentration
- Mechanical automatic engine decompression for quick and easy start-ups

Model PM7650H Includes: Nozzle Set (196499-6), Box Wrench (782237-8), Diffusion Cover (453506-1), Driver (783019-1)

Engine Displacement (cc)	75.6 cc
Engine Power	3.67 HP
Tank	3.9 gal.
Max Air Volume	496 CFM
Fuel Type	Unleaded gas
Fuel Tank Capacity	64 oz.
Crank Case Capacity	7.4 oz.
Sound Pressure	74 dB(A)
Dry Weight	22.6 lbs.
Shipping Weight	36.6 lbs.



MM4
4-STROKE ENGINE

EY2650H25H

25.4 cc MM4® TELESCOPING POLE PRUNER
Powerful MM4® Engine, No Fuel Mix Required, Lower Emissions

- Telescoping shaft easily adjusts from 8 ft. to 13 ft.
- Reduced cutting head weight for improved balance and reduced operator fatigue
- Translucent bar oil tank with automatic chain lubrication for efficient operation
- Oil view window for convenient checking of engine oil level
- Heavy duty dual-stage air filter with large sealing areas is easily accessible

Model EY2650H25H Includes: 10" Guide Bar (165695-7), Chain Protector (452093-7), 10" Saw Chain (196142-7)

Engine Displacement (cc)	25.4 cc
Engine (HP)	1.1 HP
Overall Length	154-1/2"
Guide Bar Length	10"
Fuel Type	Unleaded gas
Fuel Tank Capacity	20 oz.
Crank Case Capacity	2.7 oz.
Dry Weight	16 lbs.
Shipping Weight	24 lbs.



MM4
4-STROKE ENGINE

EE2650H

25.4 cc MM4® EDGER
No Fuel Mix Required, Lower Emissions

- 8" steel blade for precise cuts and longer blade life
- Adjustable wheel for quick and easy adjustment to desired cutting depth
- Metal skid plate protects gear housing for increased durability
- Steel drive shaft engineered for reduced vibration and longer life
- Guide marking on blade guard allows for cleaner more precise cuts
- Heavy duty dual-stage air filter with large sealing areas is easily accessible

Model EE2650H Includes: Blade (196745-7)

Engine Displacement (cc)	25.4 cc
Engine (HP)	1.1 HP
Blade Length	8"
Arbor	1"
Fuel Type	Unleaded gas
Fuel Tank Capacity	20 oz.
Crank Case Capacity	2.7 oz.
Overall Length	69-3/4"
Dry Weight	14.4 lbs.
Shipping Weight	20.3 lbs.



EN7350SH

30" 25.4 cc MM4® SINGLE-SIDED HEDGE TRIMMER

30" Single-Sided Blade With High Blade Speed (4,200 SPM) For Efficient Cutting

- Powerful fuel efficient 25.4 cc (1.1 HP), MM4® commercial duty engine
- Compact design with less weight (only 14.7 lbs.)
- Chip receiver for efficient collection and clean-up of clippings
- Steel drive shaft for less vibration and longer equipment life

Model EN7350SH Includes: Shear Blade A (725185-8), Shear Blade B (725186-6), Blade Cover (451868-1)



EN5950SH

24" 25.4 cc MM4® DOUBLE-SIDED HEDGE TRIMMER

24" Double-Sided Blade With High Blade Speed (4,200 SPM) For Efficient Cutting

- Powerful and fuel efficient 25.4 cc (1.1 HP), MM4® commercial duty engine
- Compact design with less weight (only 14.1 lbs.)
- Commercial duty gear case engineered for improved durability
- Tip guard protects blade from unnecessary wear

Model EN5950SH Includes: Shear Blade (725184-0), Blade Cover (454278-1)



EN4951SH

20" 25.4 cc MM4® ARTICULATING HEDGE TRIMMER

Articulating Gear Case With 13 Angle Settings For Efficient Trimming Of Overhead And Low-lying Hedges

- Powerful fuel efficient 25.4 cc (1.1 HP), MM4® commercial duty engine
- 180° blade adjustment allows blade to be positioned along shaft for convenient transport and storage
- Steel drive shaft for less vibration and longer equipment life
- Angle change lever quickly and easily adjusts blade angle
- 20" double-sided blade with high blade speed (4,200 SPM) for efficient cutting

Model EN4951SH Includes: Blade Cover (454279-9), Shear Blade (725187-4)



EN4950H

20" 25.4 cc MM4® ARTICULATING HEDGE TRIMMER

13 Angle Settings For Efficient Trimming Of Overhead And Low-Lying Hedges

- Powerful fuel efficient 25.4 cc (1.1 HP), MM4® commercial duty engine
- Steel drive shaft for less vibration and longer equipment life
- 20" double-sided blade with high blade speed (4,200 SPM) for efficient cutting
- Angle change lever quickly and easily adjusts blade angle
- Heavy duty dual stage air filter with large sealing areas is replaceable and easily accessible

Model EN4950H Includes: Shear Blade (725187-4), Blade Cover (452328-6)

Engine Displacement (cc)	25.4 cc
Engine (HP)	1.1 HP
Blade Length	30"
Blade Speed	4,200 SPM
Fuel Type	Unleaded gas
Fuel Tank Capacity	20.3 oz.
Crank Case Capacity	2.7 oz.
Overall Length	76-3/4"
Dry Weight	14.7 lbs.
Shipping Weight	20 lbs.

Engine Displacement (cc)	25.1 cc
Engine (HP)	1.1 HP
Blade Length	24"
Blade Speed	4,200 SPM
Fuel Type	Unleaded gas
Fuel Tank Capacity	20.3 oz.
Crank Case Capacity	20.3 oz.
Overall Length	71-1/4"
Dry Weight	14.1 lbs.
Shipping Weight	20 lbs.

Engine Displacement (cc)	25.4 cc
Engine (HP)	1.1 HP
Blade Length	20"
Blade Speed	4,200 SPM
Fuel Type	Unleaded gas
Fuel Tank Capacity	20.3 oz.
Crank Case Capacity	2.7 oz.
Overall Length	80-1/2"
Dry Weight	14.6 lbs.
Shipping Weight	21.6 lbs.

Engine Displacement (cc)	25.4 cc
Engine (HP)	1.1 HP
Blade Length	20"
Blade Speed	4,200 SPM
Fuel Type	Unleaded gas
Fuel Tank Capacity	20.3 oz.
Crank Case Capacity	2.7 oz.
Overall Length	99"
Dry Weight	15.6 lbs.
Shipping Weight	22 lbs.

4-STROKE POWERED

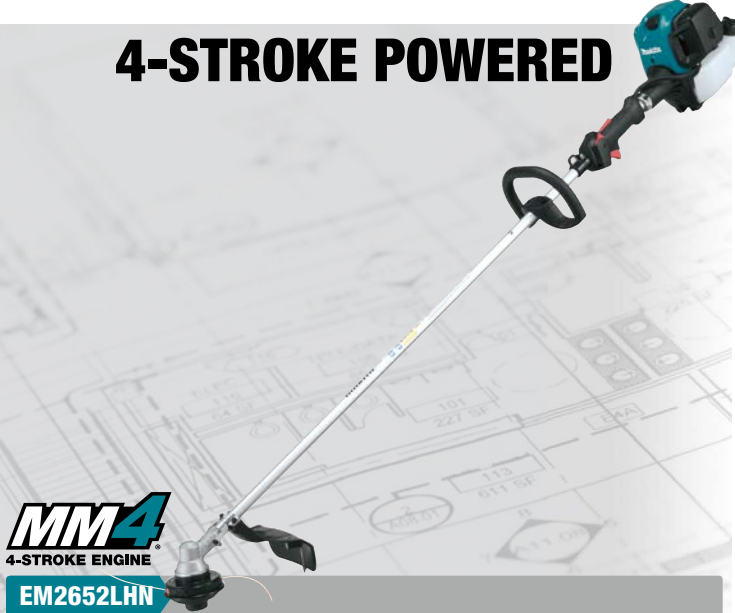

EM2652LHN

25.4 cc MM4® HIGH TORQUE STRING TRIMMER

High Torque Gear Case For Improved Cutting Performance

- Powerful and fuel efficient 25.4 cc 4-stroke commercial duty engine
- Compact design with less weight (only 11.5 lbs.)
- High capacity, rapid loading, bump-and-feed trimmer head
- Steel drive shaft engineered for less vibration and longer equipment life

Model EM2652LHN Includes: Trimmer Head, Bump and Feed (T-01753A), 4-Cycle Engine Oil, 10W-30, 2.7 oz. (195826-4)

Engine Displacement (cc)	25.4 cc
Engine (HP)	1.1 HP
Cutting Capacity (diameter)	17"
Fuel Type	Unleaded gas
Fuel Tank Capacity	20.3 oz.
Crank Case Capacity	2.7 oz.
Overall Length	69-1/2"
Dry Weight	11.5 lbs.
Shipping Weight	18 lbs.



EM2650LH

25.4 cc MM4® 4-STROKE STRING TRIMMER

Powerful Multi-Position 4-Stroke Engine

- Compact design with less weight (only 10.9 lbs.)
- High capacity, rapid loading, bump-and-feed trimmer head
- Ergonomically designed rubberized soft grip provides more comfort
- Ergonomic loop handle
- Heavy duty, dual stage air filter with large sealing areas is replaceable and easily accessible.

Model EM2650LH Includes: Trimmer Head, Bump and Feed (T-01753A), 4-Cycle Engine Oil, 10W-30, 2.7 oz. (195826-4), Wrench 4 (783223-2), Protector Set (196117-6)

Engine Displacement (cc)	25.4 cc
Engine (HP)	1.1 HP
Cutting Capacity (diameter)	17"
Fuel Type	Unleaded gas
Fuel Tank Capacity	20.3 oz.
Crank Case Capacity	2.7 oz.
Overall Length	69-1/2"
Dry Weight	10.9 lbs.
Shipping Weight	20.85 lbs.



EM2650UH

25.4 cc MM4® BRUSH CUTTER

Powerful Multi-Position 4-Stroke Engine

- Steel drive shaft for less vibration and longer equipment life
- Easily adjustable handle configuration
- Flexible universal guard for both saw blade and nylon cutting head
- Ergonomically designed rubberized soft grip provides more control and comfort
- Compact design with less weight (only 12.1 lbs.).

Model EM2650UH Includes: 9" Star Blade, 4T (B-14118), Harness (123143-2), 4-Cycle Engine Oil, 10W-30, 2.7 oz. (195826-4)

Engine Displacement (cc)	25.4 cc
Engine (HP)	1.1 HP
Blade Diameter	9"
Fuel Type	Unleaded gas
Fuel Tank Capacity	20.3 oz.
Crank Case Capacity	2.7 oz.
Overall Length	69-1/2"
Dry Weight	12.1 lbs.
Shipping Weight	17 lbs.

EASY START



MM2™
2-STROKE ENGINE

DCS642120

20" 64 cc CHAIN SAW
4.7 HP Professional Chain Saw

- Easy-starting automatic half throttle lock
- Chain compartment is easy to clean and clears chips away efficiently
- Slide out baffle can be configured for efficient cold weather operation
- Large metal spike bar for increased productivity
- Two point durable inertia/mechanical chain brake

Model DCS642120 Includes: 20" Saw Chain, 3/8", .050" (523-102-072A), 20" Guide Bar (445-050-665), Universal Wrench (941-719-131), Torx Wrench (940-827-000), 20-24" Chain Cover (952-020-660)



MM2™
2-STROKE ENGINE

EA6100P53G

20" 61 cc CHAIN SAW
4.6 HP Professional Chain Saw

- Easy Start spring-assisted starter for quick starting with less force
- Stratified Air Scavenging engine for lower emissions and improved fuel efficiency
- Magnesium housing for improved durability and less weight (only 13.2 lbs.)
- Heavy-duty cartridge air filter system for improved durability
- Touch & Stop single lever control shuts off engine with just a touch

Model EA6100P53G Includes: 20" Guide Bar (443-053-661), 20" Saw Chain, 3/8", .050" (523-102-072A), 20-24" Chain Cover (952-020-660)



MM2™
2-STROKE ENGINE

EA5000P53G

20" 50 cc CHAIN SAW
3.9 HP Professional Chain Saw

- Magnesium housing for improved durability and less weight (only 11.9 lbs.)
- Easy Start spring-assisted starter for quick starting with less force
- Compact design with less weight, (only 11.9 lbs.)
- Touch & Stop single lever control shuts off engine with just a touch
- Large dual spike bar for increased productivity

Model EA5000P53G Includes: 20" Guide Bar (443-053-661), 20" Saw Chain, 3/8", .050" (523-102-072A), 20-24" Chain Cover (952-020-660)

Engine Displacement (cu.in./cc)	3.9 cu.in. (64 cc)
Power Rating	4.7 HP/3.5 kW
Standard Guide Bar	20"
Chain Pitch	3/8"
Chain Gauge	.050"
Fuel Mixture	50:1
Fuel Tank Capacity	24.5 oz.
Oil Tank Capacity	14.2 oz.
Net Weight (w/o bar & chain)	13.9 lbs.
Shipping Weight	22 lbs.

Engine Displacement (cu.in./cc)	3.7 cu.in. (61 cc)
Power Rating	4.6 HP/3.4 kW
Standard Guide Bar	20"
Chain Pitch	3/8"
Chain Gauge	.050"
Fuel Mixture	50:1
Fuel Tank Capacity	27 oz.
Oil Tank Capacity	16 oz.
Net Weight (w/o bar & chain)	13.2 lbs.
Shipping Weight	19.2 lbs.

Engine Displacement (cu.in./cc)	3.1 cu.in. (50 cc)
Power Rating	3.9 HP/2.9 kW
Standard Guide Bar	20"
Chain Pitch	3/8"
Chain Gauge	.050"
Fuel Mixture	50:1
Fuel Tank Capacity	15.9 oz.
Oil Tank Capacity	9.1 oz.
Net Weight (w/o bar & chain)	11.9 lbs.
Shipping Weight	19 lbs.



MM2™
2-STROKE ENGINE

DCS5121

18" 50 cc CHAIN SAW
Easy Start, Spring-Assisted Starter for Quick Starting with Less Force

- Compact design with less weight (only 12.3 lbs.)
- Large dual spike bar for increased productivity
- Touch & Stop single lever control shuts off engine with just a touch
- Slide-out baffle can be configured for efficient cold weather operation
- High power-to-weight ratio 3.3 HP engine
- Two point durable inertia/mechanical chain brake

Model DCS5121 Includes: 18" Saw Chain, 3/8", .050" (523-102-064), 18" Guide Bar (446-045-661), 18" Chain Cover (952-020-650)



MM2™
2-STROKE ENGINE

EA4300F40B

16" 42 cc CHAIN SAW
High Power-to-Weight Ratio 3.0 HP Engine

- Easy Start, spring assisted starter with optimized engine management reduces force required for starting
- "Tool-less" filter maintenance for operator efficiency
- Compact design with less weight, (only 10.8 lbs.)
- Touch & Stop, single lever operation for immediate shut-off
- Large metal spike bar for increased control when cutting

Model EA4300F40B Includes: 16" Guide Bar (442-040-661), 16" Saw Chain (195400-8), 16" Chain Cover (952-010-640)



MM2™
2-STROKE ENGINE

EA3601F40B

16" 35 cc CHAIN SAW
Easy Start, Spring-Assisted for Quick Starting with Less Force

- Stratified Air Scavenging engine for lower emissions and improved fuel efficiency
- "Tool-less" chain tensioning for quick and convenient chain adjustment
- Touch & Stop single lever control shuts off engine with just a touch
- Compact design with less weight (only 9.3 lbs.)

Model EA3601F40B Includes: 16" Guide Bar (442-040-661), 16" Saw Chain (195400-8), 16" Chain Cover (952-010-640)



MM2™
2-STROKE ENGINE

EA3201S35B

14" 32 cc CHAIN SAW
Easy Start, Spring-Assisted for Quick Starting with Less Force

- "Tool-less" chain tensioning for quick and convenient chain adjustment
- Compact design with less weight (only 9.4 lbs.)
- Two point durable inertia/mechanical chain brake
- Touch & Stop single lever control shuts off engine with just a touch
- Large metal spike bar for increased productivity
- High power-to-weight ratio 1.8 HP engine

Model EA3201S35B Includes: 14" Chain (195399-7), 14" Guide Bar (442-035-661), Universal Wrench (941-719-131), 14" Chain Cover (952-010-630)

Engine Displacement (cu.in./cc)	3.1 cu.in. (50 cc)
Power Rating	3.3 HP/2.5 kW
Standard Guide Bar	18"
Chain Pitch	3/8"
Chain Gauge	.050"
Fuel Mixture	50:1
Fuel Tank Capacity	15.9 oz.
Oil Tank Capacity	9.1 oz.
Net Weight (w/o bar & chain)	12.3 lbs.
Shipping Weight	17.6 lbs.

Engine Displacement (cu.in./cc)	4.2 cu.in. (2.6 cc)
Power Rating	3 HP/2.2 kW
Standard Guide Bar	16"
Chain Pitch	3/8"
Chain Gauge	.050"
Fuel Mixture	50:1
Fuel Tank Capacity	16.2 oz.
Oil Tank Capacity	9.5 oz.
Net Weight (w/o bar & chain)	10.8 lbs.
Shipping Weight	15 lbs.

Engine Displacement (cu.in./cc)	2.1 cu.in. (35.2 cc)
Power Rating	2.4 HP/1.8 kW
Standard Guide Bar	16"
Chain Pitch	3/8"
Chain Gauge	.050"
Fuel Mixture	50:1
Fuel Tank Capacity	10.5 oz.
Oil Tank Capacity	8.8 oz.
Net Weight (w/o bar & chain)	9.3 lbs.
Shipping Weight	13.6 lbs.

Engine Displacement (cu.in./cc)	2 cu.in. (32 cc)
Power Rating	1.8 HP/1.3 kW
Standard Guide Bar	14"
Chain Pitch	3/8"
Chain Gauge	.050"
Fuel Mixture	50:1
Fuel Tank Capacity	13.5 oz.
Oil Tank Capacity	9.5 oz.
Net Weight (w/o bar & chain)	9.4 lbs.
Shipping Weight	13.86 lbs.

EASY OPERATION & MAINTENANCE



UC4051A

16" ELECTRIC CHAIN SAW Heavy-Duty for Fast and Efficient Cutting

- "Tool-less" blade and chain adjustments for convenient operation and easy maintenance
- Rubberized grip handles are ergonomically designed for comfort
- Built-in current limiter helps protect motor from burnout
- Large oil reservoir with view window allows operator to check bar oil level

Model UC4051A Includes: 16" Saw Chain, 3/8"-.050" (196208-3), 16" Guide Bar (442-040-661), 16" Chain Cover (952-010-640)

Chain Speed	2,900 FPM
Guide Bar Length	16"
Chain Pitch	3/8"
Chain Gauge	.050"
Oil Tank Capacity	6.8 oz.
Overall Length	19-7/8"
Net Weight (w/o bar & chain)	12.3 lbs.
Shipping Weight	15.7 lbs.



UC3551A

14" ELECTRIC CHAIN SAW Heavy-Duty for Fast and Efficient Cutting

- "Tool-less" blade and chain adjustments
- Rubberized grip handles are ergonomically designed
- Large trigger switch with soft start for smooth start-ups
- Built-in current limiter helps protect motor
- Large oil reservoir with view window allows operator to check oil level
- Automatic chain oiler for heavy continuous cutting

Model UC3551A Includes: 14" Saw Chain, 3/8"-.050" (196207-5), 14" Guide Bar (442-035-661), 14" Chain Cover (952-010-630)

Chain Speed	2,900 FPM
Guide Bar Length	14"
Chain Pitch	3/8"
Chain Gauge	.050"
Oil Tank Capacity	6.8 oz.
Overall Length	19-7/8"
Net Weight (w/o bar & chain)	12.1 lbs.
Shipping Weight	16.5 lbs.



5012B

11-3/4" ELECTRIC CHAIN SAW Compact and Lightweight (9.5 lbs.)

- 5,500 FPM chain speed for extremely fast cutting ability
- Durable poly-carbonate housing for long-lasting performance
- Built-in overload protector for durability
- 11.5 AMP motor powers through stock for smooth and fast cutting
- Special sprocket inside the end of the chain bar for smooth chain action
- Engineered for reliable and durable performance

Model 5012B Includes: 12" Saw Chain, 3/8"-.050" (196519-6), Bar Chain Oil, 100 cc (182229-1), File, 5012B (744003-1), Cord Hook (158024-1)

Guide Bar Length	11-3/4"
Chain Speed	5,500 FPM
Chain Pitch	3/8"
Chain Gauge	.050"
AMPS	11.5
Net Weight (w/o bar & chain)	9.5 lbs.
Overall Length	22"
Shipping Weight	12 lbs.



UH6570

25" ELECTRIC HEDGE TRIMMER Large Cutting Capacity and High Performance

- Ergonomic grip design for improved comfort and handling
- Well balanced and with less weight
- Low motor noise level for quiet operation
- Two-hand operation switch, motor runs only when grips are held with both hands
- Large, transparent hand guard permits a good view of the work area
- Engineered for lower vibration and increased user comfort

Model UH6570 Includes: Shear Blade Assembly, UH6570 (194669-1), Shear Blade Cover, UH5570, UH6570 (450490-1), Cord Hook (158024-1), Cord Holder (194677-2)

Capacities: Cutting Diameter:	1/2"
Cutting Length:	25-1/2"
Blade Speed	1,600 SPM
AMPS	4.8
Overall Length	44-3/4"
Net Weight	8.2 lbs.
Shipping Weight	10.7 lbs.



UH5570

22" ELECTRIC HEDGE TRIMMER Large Cutting Capacity and High Performance

- Ergonomic grip design for improved comfort and handling
- Well balanced and with less weight
- Low motor noise level for quiet operation
- Two-hand operation switch, motor runs only when grips are held with both hands
- Large, transparent hand guard permits a good view of the work area
- Engineered for lower vibration and increased user comfort

Model UH5570 Includes: Shear Blade Assembly (194665-9), Shear Blade Cover, UH5570, UH6570 (450490-1), Cord Hook (158024-1), Cord Holder (194677-2)

Capacities: Cutting Diameter:	1/2"
Cutting Length:	21-5/8"
Blade Speed	1,600 SPM
AMPS	4.8
Overall Length	40-1/2"
Net Weight	7.9 lbs.
Shipping Weight	10.5 lbs.



MAKITA® GEAR

Get all dialed in with the latest Makita swag. Check out the all-new line of apparel including race team replica hats, t-shirts and sweatshirts.

Stay on top of your game with current promotional items! There's lots of other cool stuff too; Ogio backpacks and luggage, barstools, mugs, key chains and more.

Shop now at:
makitatools.com/gear



GET CONNECTED

Makitatools.com has the latest updates on new tools, Makita® innovation, promotions, where to buy, or to find when Makita events are taking place near you. Content is updated constantly to keep you on top of your game... whether that game is work or play.

makitatools.com

FOLLOW MAKITA®





HCU02C1

36v CHAIN SAW KIT

Zero Emissions and up to 40% Quieter Than Gas

- Makita-built motor delivers 1,650 FPM for increased cutting speed
- Lower noise level at only 89 dB(A) for improved user comfort
- "Tool-less" chain adjustments for convenient operation and maintenance
- Front hand guard engineered to actuate chain brake when engaged
- 12" guide bar for increased capacity

Model HCU02C1 Includes: 36V Lithium-Ion Battery (BL3622A), 36V Charger (DC36WA), 12" Guide Bar (165245-8), 12" Saw Chain (531-290-046)

Guide Bar Length	12"
Chain Speed	1,650 FPM
Chain Pitch	3/8"
Chain Gauge	.043"
Battery	36V LXT® Lithium-Ion
Overall Length	24-5/8"
Net Weight (with battery)	10.1 lbs.
Shipping Weight	14 lbs.

18v BATTERIES 36v PERFORMANCE



XCU02Z

18v X2 LXT® (36v) CHAIN SAW

Powered by Two 18v LXT® Lithium-Ion Batteries

- Makita-built motor delivers 1,650 FPM chain speed for fast cutting
- Two 18V LXT® Lithium-Ion batteries deliver power and performance without leaving the 18V LXT® platform (batteries not included)
- 12" guide bar for increased capacity
- "Tool-less" chain adjustments for convenient operation and maintenance
- Front hand guard actuates chain brake when engaged

Model XCU02Z Includes: Tool Only - 12" Guide Bar (165245-8), 12" Saw Chain (531-290-046), Blade Cover; Battery and Charger not included

Guide Bar Length	12"
Chain Speed	1,650 FPM
Chain Pitch	3/8"
Chain Gauge	.043"
Battery	2X 18V LXT® Lithium-Ion
Overall Length	24-5/8"
Net Weight (with battery)	11.2 lbs.
Shipping Weight	8.8 lbs.



XCU01Z

Tool only - battery and charger not included

18v LXT® 4-1/2" CHAIN SAW

The Perfect Chain Saw for Limbing, Powered by 18v LXT®

- Makita-built motor delivers 980 FPM for increased cutting speed
- 4-1/2" guide bar is ideal for limbing
- "Tool-less" chain adjustments for convenient operation and maintenance
- Zero emissions and reduced maintenance
- Compact and ergonomic design at only 16-5/8" long
- Weighs only 5.4 lbs. with battery (battery not included) for reduced operator fatigue

Model XCU01Z Includes: Tool Only - 4-1/2" Saw Chain, 1/4"-.050", LXC01, UC120DWD (791284-8), 4-1/2" Guide Bar, LXC01, UC120DWD (158476-6); Battery and Charger not included

Guide Bar Length	4-1/2"
Chain Speed	980 FPM
Chain Pitch	1/4"
Chain Gauge	.050"
Battery	18V LXT® Lithium-Ion
Overall Length	16-5/8"
Net Weight (with battery)	5.4 lbs.
Shipping Weight	7.1 lbs.



HHU01C1

36v HEDGE TRIMMER KIT

36v Lithium-Ion Battery Delivers the Cutting Performance of a Corded Trimmer

- Makita-built motor delivers 1,800 SPM for fast cutting
- 25-1/2" blade provides increased cutting capacity
- 6 speed dial (0 - 1,800 SPM) allows the user to match the speed to the application
- Lower noise level at only 86.5 dB(A); up to 30% quieter than gas
- 5-position rotating rear handle for increased comfort during vertical and angle trimming

Model HHU01C1 Includes: Tool Only - 36V Charger (DC36WA), 36V Lithium-Ion Battery (BL3622A); Battery and Charger not included

Blade Length	25-1/2"
Strokes Per Minute	1,800 SPM
Battery	36V LXT® Lithium-Ion
Overall Length	48-3/4"
Net Weight (with battery)	11.7 lbs.
Shipping Weight	19.8 lbs.



XHU04Z

Tool only - battery and charger not included

18v X2 LXT® HEDGE TRIMMER

Two 18v LXT® Lithium-Ion Batteries Deliver the Cutting Performance of a Corded Trimmer

- Makita-built motor delivers 1,800 SPM for fast cutting
- 25-1/2" blade provides increased cutting capacity
- 6 speed dial (0 - 1,800 SPM) allows the user to match the speed to the application
- Lower noise level at only 86.5 dB(A); up to 30% quieter than gas
- Weighs only 13.3 lbs. with (2) 18V batteries (batteries not included) for reduced operator fatigue

Model XHU04Z Includes: Tool Only - Blade Cover; Battery and Charger not included

Blade Length	25-1/2"
Strokes Per Minute	1,800 SPM
Battery	2X 18V LXT® Lithium-Ion
Overall Length	48-3/4"
Net Weight (with battery)	13.3 lbs.
Shipping Weight	13.7 lbs.



XHU02Z

Tool only - battery and charger not included

18v LXT® HEDGE TRIMMER

Up to 75 Minutes of Run Time with 3.0Ah Battery on Lowest Setting

- Makita-built motor delivers 1,350 SPM for increased cutting speed
- 22" blade provides increased cutting capacity
- Anti-vibration design (five cushions within the motor housing) helps minimize vibration
- Battery capacity warning system; motor stops and light goes on indicating battery needs recharging (battery and charger sold separately)
- Lower noise level at only 87 dB(A) for operator comfort
- Compact and ergonomic design at only 38" long

Model XHU02Z Includes: Tool Only - Blade Cover (450490-1); Battery and Charger not included

Blade Length	22"
Strokes Per Minute	1,350 SPM
Battery	18V LXT® Lithium-Ion
Overall Length	38"
Net Weight (with battery)	7.4 lbs.
Shipping Weight	9.1 lbs.



XRU07Z

Tool only - battery and charger not included

18v X2 LXT® (36v) BRUSHLESS STRING TRIMMER

Zero Emissions and Reduced Maintenance; No Need for Gas or Oil

- Makita-built Outer Rotor BL™ Brushless Motor direct-drive system provides high power and increased torque
- Constant Speed Control minimizes reduction in rotation speed under load
- 2-speed options (Low: 0-5,000 RPM, High: 0-6,500 RPM) allows the operator to match speed to application
- Delivers up to 60 minutes of run time under load on the low speed setting using two 18V LXT® 5.0Ah BL1850 batteries¹

Model XRU07Z Includes: Tool Only - Bump & Feed Trimmer Head, XRU07 Trimmer Head (197297-1), Goggles (195246-2), Hex Wrench (783217-7), Hex Wrench (783202-0), Accessory Bag (831304-7); Battery and Charger not included

Cutting Capacity (diameter)	13-3/4"
No Load Speed (2 spd)	5,000/6,500 RPM
Battery	2X 18V LXT® Lithium-Ion
Overall Length	69"
Net Weight (with battery)	9.9 lbs.
Shipping Weight	12.1 lbs.

¹ Under Load: 13-3/4" cutting swath with .080" nylon line, approximate run time will vary according to grass conditions



XRU04Z Tool only - battery and charger not included

18v LXT® BRUSHLESS STRING TRIMMER

Up to 60 Minutes of Run Time with 3.0Ah Battery under No Load on the Lowest Setting

- BL™ Brushless motor delivers up to 6,000 RPM for faster cutting
- Adjustable speed dial (0-3,500 to 0-6,000 RPM) allows the operator to match speed to application
- Compact size is ideal for trimming and precise edging
- Zero emissions and reduced maintenance; no need for gas or oil

Model XRU04Z Includes: Tool Only - Trimmer Head (123235-7), Shoulder Strap (125516-5), Goggles (195246-2), Hex Wrench (783217-7), Hex Wrench (783202-0), Accessory Bag (831304-7); Battery and Charger not included

Cutting Capacity (diameter)	11-3/4"
No Load Speed (2 spd)	3,500/6,000 RPM
Battery	18V LXT® Lithium-Ion
Overall Length	72-1/2"
Net Weight (with battery)	8.6 lbs.
Shipping Weight	18.7 lbs.



XRU02Z Tool only - battery and charger not included

18v LXT® STRING TRIMMER
Up to 45 Minutes of Run Time with 3.0Ah Battery Under No Load

- Makita-built motor delivers 7,800 RPM for faster cutting
- Telescoping shaft (48-1/2" to 56-1/2") for optimum cutting position
- Adjustable 5-position pivoting head for cutting angle adjustment when trimming in tight spaces
- 180° rotating head allows the trimmer to convert to edger; 10-1/4" cutting width
- Compact size is ideal for trimming and precise edging

Model XRU02Z Includes: Tool Only - Trimmer Head (196146-9), Nylon Cord (196148-5); Battery and Charger not included

Cutting Capacity (diameter)	10-1/4"
No Load Speed	7,800 RPM
Battery	18V LXT® Lithium-Ion
Overall Length	10-1/4"
Net Weight (with battery)	6.9 lbs.
Shipping Weight	8.8 lbs.



XMU02Z Tool only - battery and charger not included

18v LXT® GRASS SHEAR
Up to 125 Minutes of Run Time with 3.0Ah battery Under No Load

- Makita-built motor delivers 1,250 SPM for efficient cutting
- Toboggan-style base frame enables user to quickly adjust height to match the application
- Dual blade action cuts with a shearing effect for improved results
- Non-electrolyzed nickel plated blades engineered to resist staining and rusting
- Weighs only 3.6 lbs. with battery (battery not included) for reduced user fatigue

Model XMU02Z Includes: Tool Only - Blade Cover (452055-5); Battery and Charger not included

Cutting Capacity (width)	6-5/16"
Depth Adjustment Range	3/8", 13/16", 1-3/16"
No Load Speed	1,250 RPM
Battery	18V LXT® Lithium-Ion
Overall Length	13-7/8"
Net Weight (with battery)	3.6 lbs.
Shipping Weight	3.45 lbs.

NO LIMITS
POWER & SPEED TO UNPLUG THE CORD



UNPLUG YOUR CORDED TOOLS and pick up Makita's 18v X2 (36v) Lithium-Ion line up. Get the freedom you need to reach new heights with unmatched run time - you'll never look back.

36v POWER
(2) 18v BATTERIES



Learn More ▶ makitatools.com/X2

PORTABLE & VERSATILE



18v + 18v = 36v

XBU02Z Tool only - battery and charger not included

18v X2 LXT® (36v) BRUSHLESS BLOWER
Makita-Built BL™ Brushless Motor Produces A Maximum 473 CFM

- Delivers up to 29 minutes of run time at 15,800 RPM using two 18V LXT® 5.0Ah batteries
- Makita-built motor produces a maximum air velocity of 120 MPH
- 6-stage air velocity/volume selection dial with variable speed control trigger
- Two 18V LXT® Lithium-Ion batteries deliver the power and run time for gas powered demands without leaving the 18V LXT® platform
- Zero emissions and reduced maintenance; no need for gas or oil

Model XBU02Z Includes: Tool Only - Long Nozzle (455915-0); Battery and Charger not included

Max Air Volume	473 CFM
Max. Air Velocity	120 MPH
No Load Speed (variable speed)	11,400 - 21,500 RPM
Battery	2X 18V LXT® Lithium-Ion
Sound Pressure	96 dB(A)
Overall Length	38-3/4"
Net Weight (with battery)	9.9 lbs.
Shipping Weight	8.4 lbs.



18v + 18v = 36v

XBU01Z Tool only - battery and charger not included

18v X2 LXT® (36v) BLOWER
Makita-built Motor Produces a Maximum Air Volume of 155 CFM

- Delivers up to 28 minutes of run time using two 5.0Ah 18V LXT® batteries on highest speed setting
- Makita-built motor produces a maximum air velocity of 208 MPH
- 2-speed (Low: 10,000 RPM, High: 17,000 RPM) design to match the speed to application
- Two 18V LXT® Lithium-Ion batteries deliver the power and run time for corded demands without leaving the 18V LXT® platform
- Compact and ergonomic design at only 36-1/4" long

Model XBU01Z Includes: Tool Only - Long Blower Nozzle (452123-4); Battery and Charger not included

Max Air Volume	155 CFM
Max. Air Velocity	208 MPH
No Load Speed (2 spd)	10,000/17,000 RPM
Battery	2X 18V LXT® Lithium-Ion
Sound Pressure	86 dB(A)
Overall Length	36-1/4"
Net Weight (with battery)	8 lbs.
Shipping Weight	6 lbs.



UB360DWB

36v BLOWER KIT
Delivers up to 14 Minutes of Run Time with 36v Battery Under No Load on Highest Setting

- Makita-built motor produces a maximum air velocity of 208 MPH with up to 30 min. of continuous run time
- 2-speed (Low: 10,000 RPM, High: 17,000 RPM) design to match the speed to application
- Lower noise level at only 86 dB(A) for improved user comfort, 30% quieter than gas
- Zero emissions, and reduced maintenance for increased ease of use

Model UB360DWB Includes: 36V Lithium-Ion Battery (BL3622A), 36V Charger (DC36WA), Long Blower Nozzle (452123-4)

Max Air Volume	155 CFM
Max. Air Velocity	208 MPH
No Load Speed (2 spd)	10,000/17,000 RPM
Battery	36V LXT® Lithium-Ion
Sound Pressure	86 dB(A)
Overall Length	36-1/4"
Net Weight (with battery)	6.8 lbs.
Shipping Weight	11 lbs.